

HA13116

T-74-05-01

20 W BTL Audio Power Amplifier

The HA13116 is a high output and low distortion power IC designed for component car stereo amplifiers. At 13.2 V to 4 Ω load, this power IC provides an output power of 16 W with 1 % distortion and 20 W with 10 % distortion. It is easy to design as this IC employs internal each protection circuit and the new small package.

Features

- Low external components count
- Small outline package, easy to mount
- Internal each protection circuits
 - Surge protection circuit
 - Thermal shut-down circuit
 - Ground fault protection circuit

Ordering Information

Type No.	Package
HA13116	SP-15

Table 1 Absolute Maximum Ratings (Ta = 25 °C)

Item	Symbol	Rating	Unit	Note
Operating supply voltage	Vcc	18	V	
DC supply voltage	Vcc (DC)	26	V	1
Peak supply voltage	Vcc (peak)	50	V	2
Output current	Io (peak)	4	A	
Power dissipation	PT	15	W	
Thermal resistance	θj-c	3.5	°C/W	
Junction temperature	Tj	150	°C	
Operating temperature	Topr	-30 to +80	°C	
Storage temperature	Tstg	-55 to +125	°C	

- Notes: 1. Value at t = 30 sec.
 2. Value at width tw = 200 ms and rise time tr = 1 ms.

Table 2 Electrical Characteristics (Vcc = 13.2 V, f = 1 kHz, RL = 4 Ω, Ta = 25 °C)

Item	Symbol	Min	Typ	Max	Unit	Test conditions
Quiescent current	IQ	40	80	180	mA	Vin = 0
Input bias voltage	VB	—	20	70	mV	Vin = 0
Output offset voltage	ΔVQ	—	—	+330	mV	Vin = 0
Voltage gain	GV	37.5	40	42.5	dB	Vin = -30 dBm



334 Hitachi America, Ltd. • Hitachi Plaza • 2000 Sierra Point Pkwy. • Brisbane, CA 94005-1819 • (415) 589-8300

HA13116

Electrical Characteristics (Vcc = 13.2 V, f = 1 kHz, RL = 4 Ω, Ta = 25 °C) (cont) T-74-05-01

Output power	Pout	10	16	—	W	THD = 1 %
		—	20	—		THD = 10 %
Total harmonic distortion	THD	—	0.05	0.12	%	Pout = 1.5 W
Output noise voltage	WBN	—	0.25	0.5	mV	Rg = 10 kΩ, BW = 20 Hz 20 kHz
Supply voltage rejection ratio	SVR	40	50	—	dB	f = 500 Hz, Rg = 4.7 kΩ
Input resistance	Rin	—	68	—	kΩ	
Rolloff frequency	fL	—	5	—	Hz	ΔGv = -3 dB Low from
	fH	40	70	120	kHz	f = 1 kHz Ref. High

Typical Application Circuit

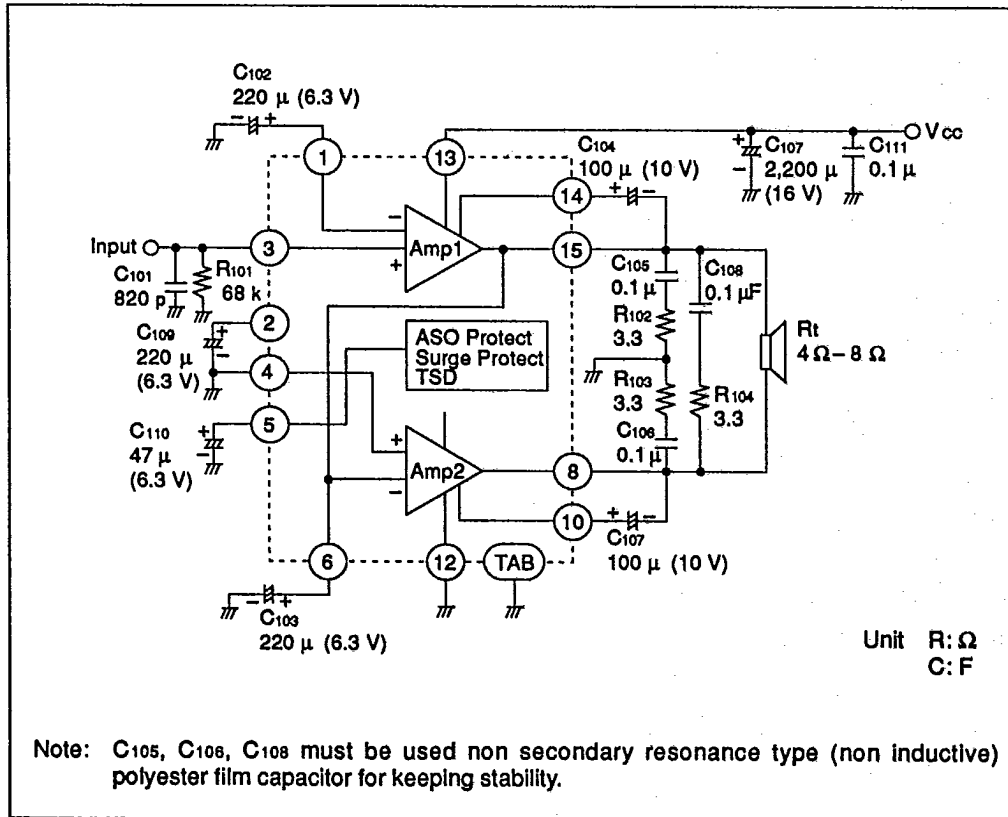

HA13116

T-74-05-01

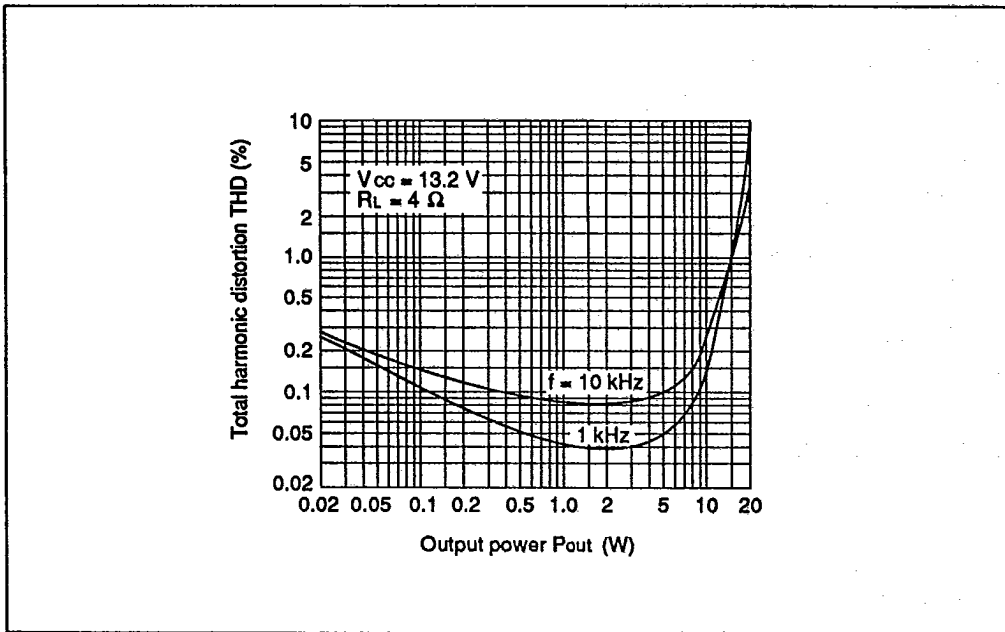

Total Harmonic Distortion vs. Output Power

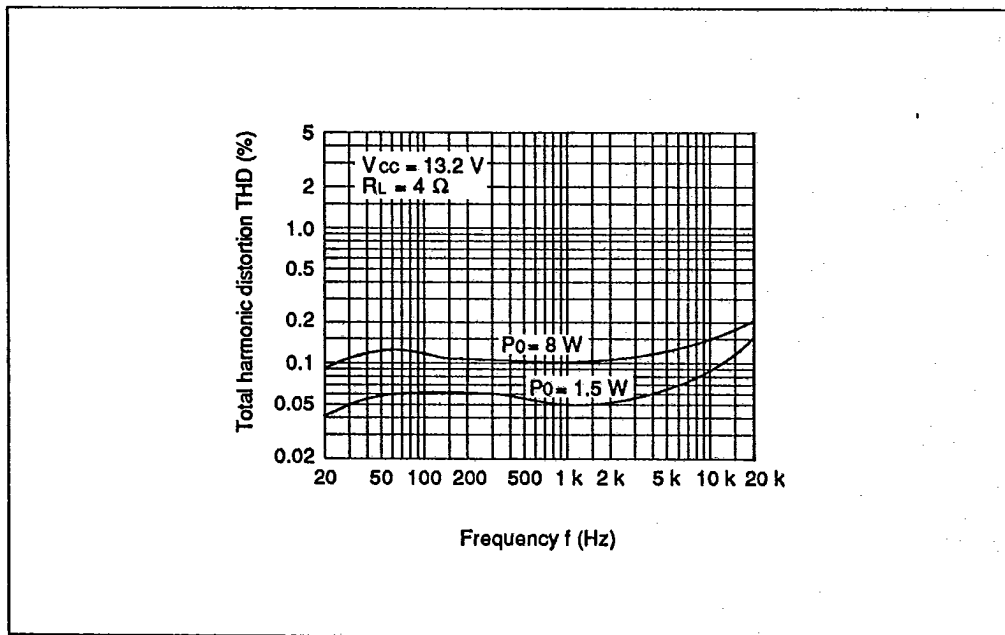

Total Harmonic Distortion vs. Frequency



T-74-05-01

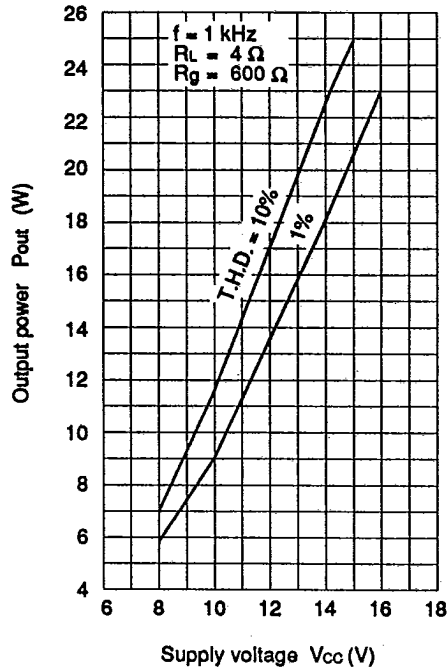

Output Power vs. Supply Voltage

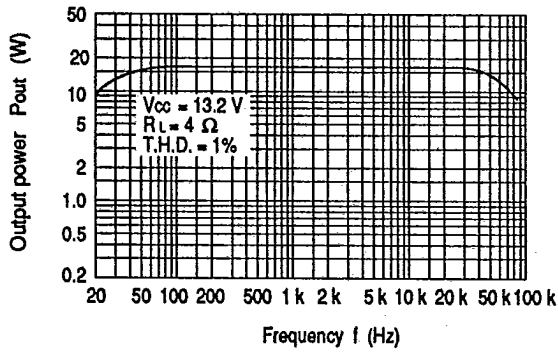

Output Power vs. Frequency



T-74-05-01

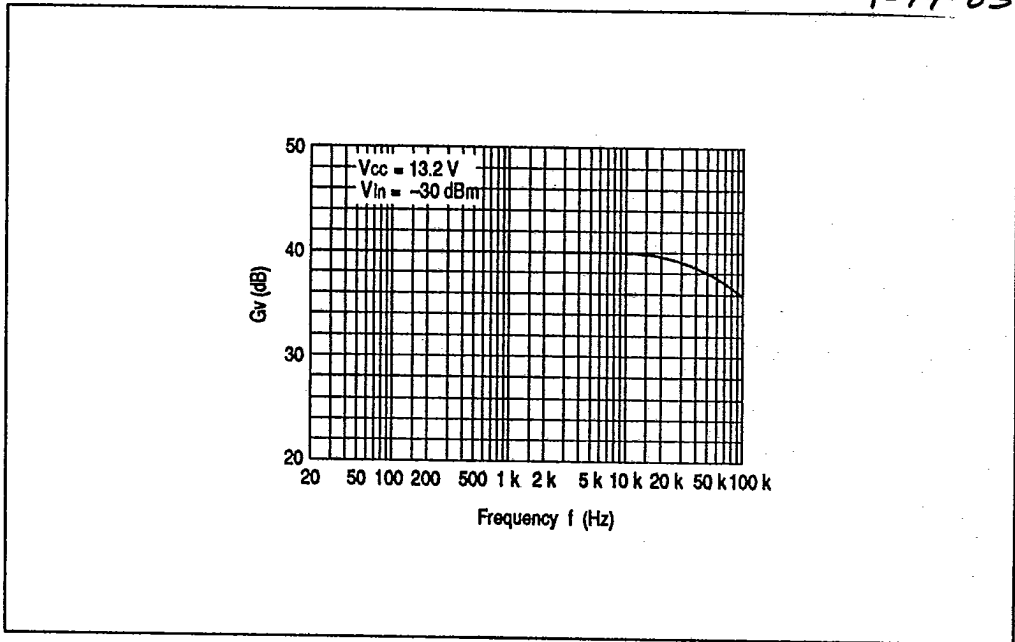

Voltage Gain vs. Frequency

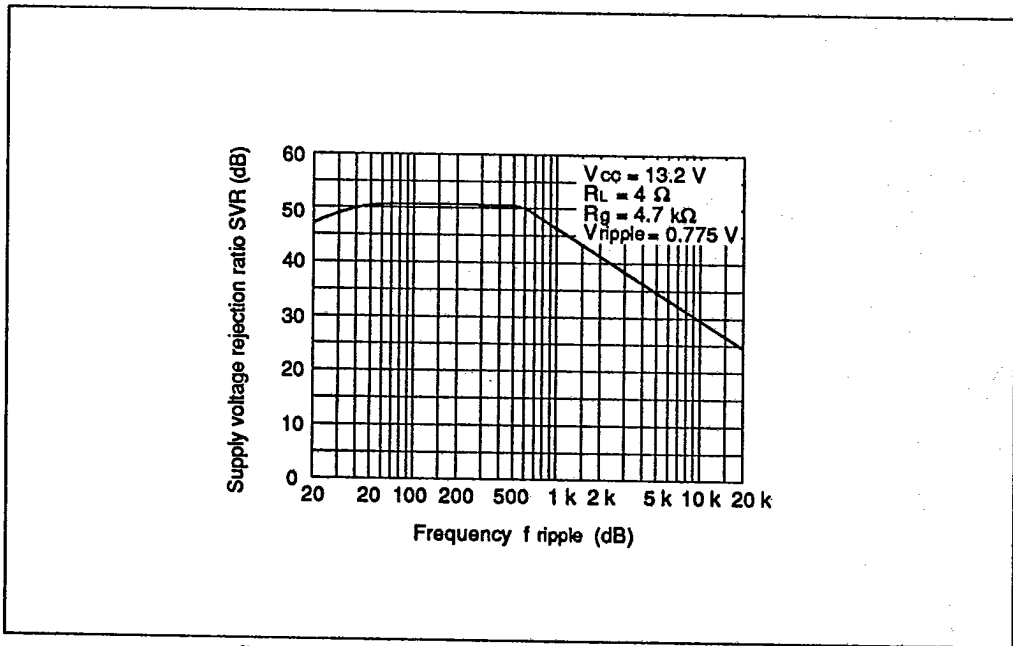

Supply Voltage Rejection Ratio vs. Frequency



T-74-05-01

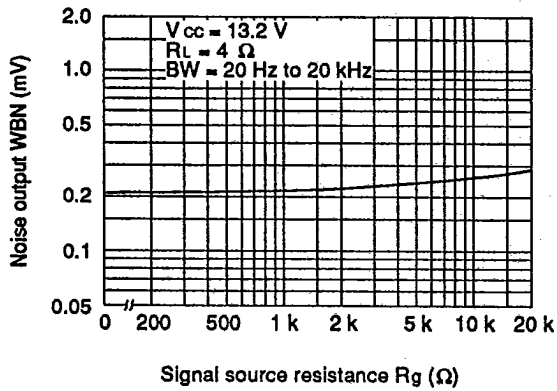

Noise Output vs. Signal Source Resistance

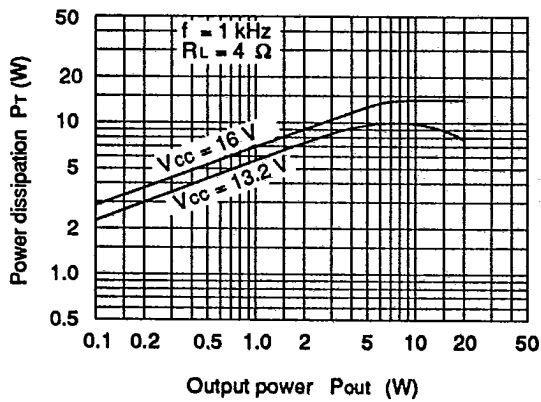

Power Dissipation vs. Output Power



HA13116

T-74-05-01

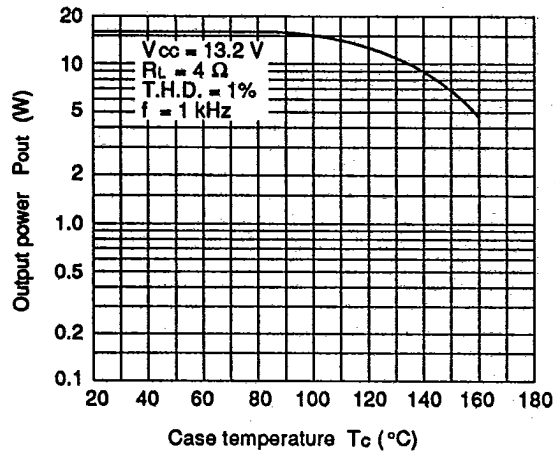

Output Power vs. Case Temperature



This datasheet has been download from:

www.datasheetcatalog.com

Datasheets for electronics components.