

BYWF29-50 THRU BYWF29-200

FAST EFFICIENT PLASTIC RECTIFIER

Reverse Voltage - 50 to 200 Volts

Forward Current - 8.0 Amperes

ITO-220AC

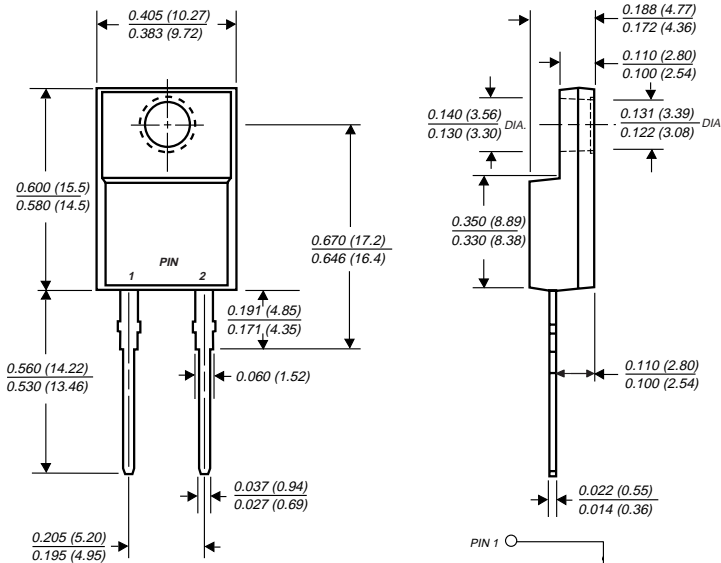

Dimensions in inches and (millimeters)

FEATURES

- ◆ Plastic package has Underwriters Laboratory Flammability Classification 94V-0
- ◆ Glass passivated chip junction
- ◆ Low power loss
- ◆ Low leakage current
- ◆ High surge current capability
- ◆ Superfast recovery time for high efficiency
- ◆ High temperature soldering guaranteed: 250°C, 0.25" (6.35mm) from case for 10 seconds



MECHANICAL DATA

Case: JEDEC ITO-220AC molded plastic body over passivated chip

Terminals: Plated lead solderable per MIL-STD-750, Method 2026

Polarity: As marked

Mounting Position: Any

Weight: 0.064 ounce, 1.81 grams

Mounting Torque: 5 in. - lbs. max.

MAXIMUM RATINGS AND ELECTRICAL CHARACTERISTICS

Ratings at 25°C ambient temperature unless otherwise specified.

	SYMBOLS	BYWF29-50	BYWF29-100	BYWF29-150	BYWF29-200	UNITS
Maximum repetitive peak reverse voltage	V _{RRM}	50	100	150	200	Volts
Maximum RMS voltage	V _{RMS}	35	70	105	140	Volts
Maximum DC blocking voltage	V _{DC}	50	100	150	200	Volts
Maximum average forward rectified current at T _C =125°C	I _(AV)	8.0				Amps
Peak forward surge current 10ms single half sine-wave superimposed T _J =150°C	I _{FSM}	100.0				Amps
Maximum instantaneous forward voltage at: I _F =20A, T _J =25°C I _F =8A, T _J =150°C	V _F	1.3 0.8				Volts
Maximum DC reverse current at rated DC blocking voltage T _C =25°C T _C =100°C	I _R	10.0 500.0				μA
Maximum reverse recovery time (NOTE 1)	t _{rr}	25.0				ns
Typical junction capacitance (NOTE 2)	C _J	45.0				pF
Maximum thermal resistance (NOTE 3)	R _{θJC}	4.5				°C/W
Operating and storage temperature range	T _J , T _{STG}	-65 to +150				°C

NOTES:

- (1) Reverse recovery test conditions: I_F=1A, V_R=30V, di/dt=100A/μs, I_{rr}=10%, I_{RM} for measurement of t_{rr}
- (2) Measured at 1.0 MHz and applied reverse voltage of 4.0 Volts
- (3) Thermal resistance from junction to case mounted on heatsink

RATINGS AND CHARACTERISTIC CURVES BYWF29-50 THRU BYWF29-200

FIG. 1 - MAXIMUM FORWARD CURRENT DERATING CURVE

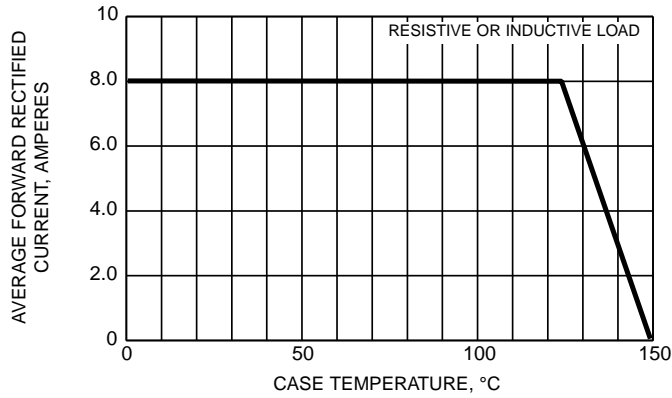

FIG. 2 - MAXIMUM NON-REPETITIVE PEAK FORWARD SURGE CURRENT

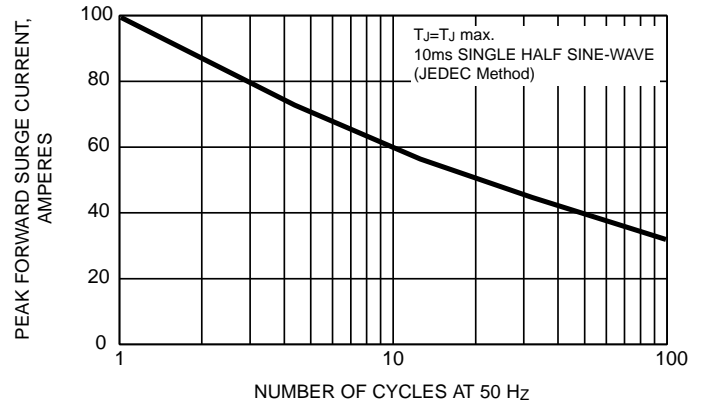

FIG. 3 - TYPICAL INSTANTANEOUS FORWARD CHARACTERISTICS

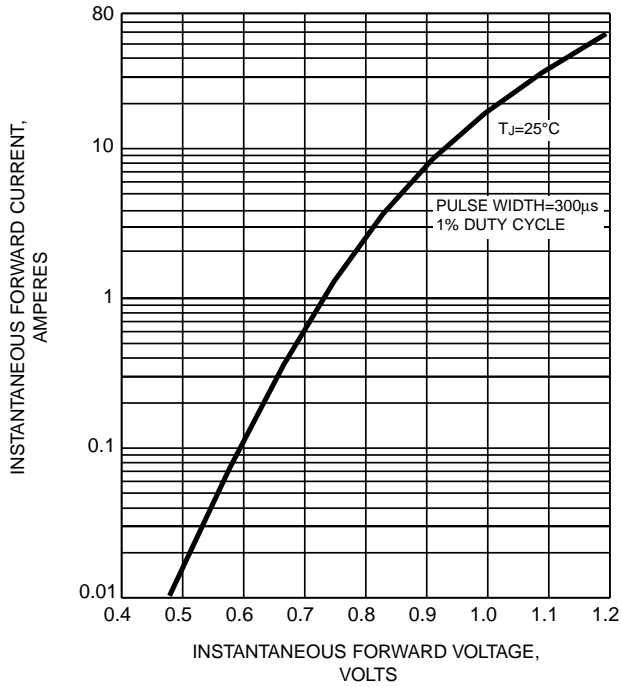

FIG. 4 - TYPICAL REVERSE LEAKAGE CHARACTERISTICS

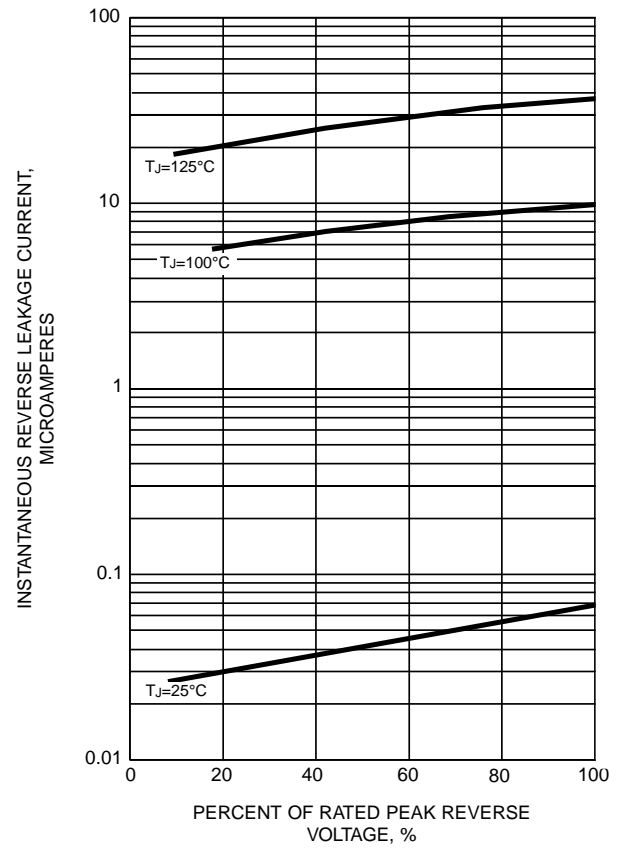

FIG. 5 - TYPICAL JUNCTION CAPACITANCE

