

3-wire Serial EEPROMs 1K/2K/4K AF93BC46/56/66

FEATURES:

- Internally organized as 128 x 8 or 64 x 16(1K), 256 x 8 or 128 x 16 (2K), 512 x 8 or 256 x 16 (4K)
- Wide-voltage range operation
 - 1.8V-5.5 V
- 3-wire serial interface bus
- Data retention: 100 years
- High endurance: 1,000,000 Write Cycles
- 2 MHz (5V) clock rate
- Sequential read operation
- Self-timed write cycle (10ms max)
- Lead free package
- 8-pin PDIP, 8-pin JEDEC SOIC, and 8-pin TSSOP Packages

DESCRIPTION

Aplus Flash Technology's AF93BC family provides 1K, 2K and 4K of serial electrically erasable and programmable read-only memory (EEPROM). The wide V_{dd} range allows for low-voltage operation down to 1.8V and up to 5.5V. The device, fabricated using traditional CMOS EEPROM technology, is optimized for many industrial and commercial applications where low-voltage and low-power operation is essential. The AF93BC46/56/66 is available in 8-pin PDIP, 8-pin JEDEC SOIC, and 8-pin TSSOP packages and is accessed via a 3-wire serial interface.

Figure 1. Pin Configurations

8-pin PDIP/TSSOP/SOIC

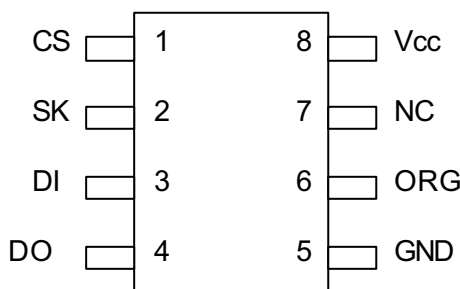

Pin Name	Function
CS	Chip Select
SK	Serial Data Clock
DI	Serial Data Input
DO	Serial Data Output
GND	Ground
Vcc	Power Supply
ORG	Internal Organization
NC	No Connect



ABSOLUTE MAXIMUM RATINGS

Operating Temperature.....	-55°C to +125°C
Storage Temperature.....	-65°C to +150°C
Voltage on Any Pin with Respect to Ground.....	- 1.0V to Vcc + 7.0V
Maximum Operating Voltage.....	6.25V
DC Output Current.....	5.0 mA

Note: Stresses beyond those listed under “Absolute Maximum Ratings” may cause permanent damage to the device. This is a stress rating only and functional operation of the device at these or any other conditions beyond those indicated in the operational sections of this specification is not implied. Exposure to absolute maximum rating conditions for extended periods may affect device reliability.

Figure 2. Block Diagram

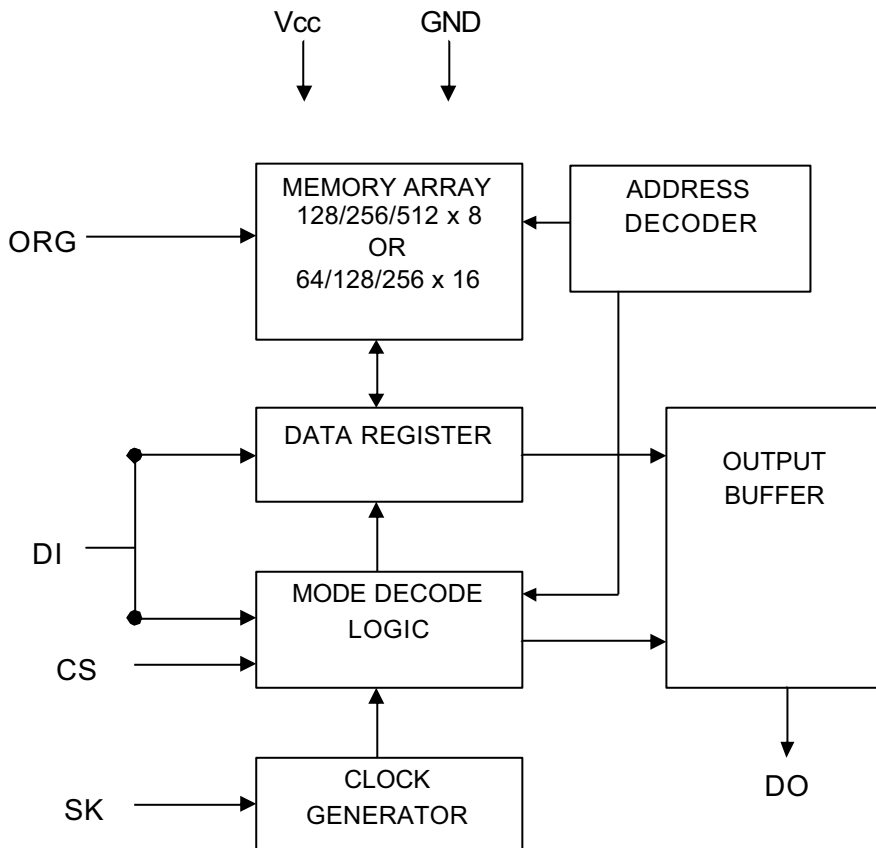

Notes

1. The ORG pin is used to select between x8 and x16 mode. When the pin is connected to Vcc, x16 mode is selected. Otherwise, the ORG pin should be grounded in order to select x8 mode.

The interface for the AF93BC46/56/66 is accessed through four different signals: Chip Select (CS), Data Input (DI), Data Output (DO), and Serial Data Clock (SK). The Chip Select (CS) signal must be pulled high before issuing a command through the Data Input (DI) pin. The Serial Data Clock (SK) signal is used in conjunction with the Data Input (DI) pin.



PIN CAPACITANCE

Applicable over recommended operating range from $T_A = 25^\circ\text{C}$, $f = 1.0\text{ MHz}$, $V_{CC} = +5.0\text{V}$

Symbol	Test Condition	Max	Units	Condition
C_{OUT}	Output Capacitance (DO)	5	pF	$V_{OUT} = 0\text{V}$
C_{IN}	Input Capacitance (CK, SK, DI)	5	pF	$V_{IN} = 0\text{V}$

Note: 1. This parameter is characterized and not 100% tested.

DC CHARACTERISTICS

Applicable over recommended operating range from:

$T_{AMB} = -40^\circ\text{C}$ to $+85^\circ\text{C}$, $V_{CC} = +1.8\text{V}$ to $+5.5\text{V}$ (unless otherwise noted)

Symbol	Parameter	Test Condition	Min	Typ	Max	Units
V_{CC1}	Supply Voltage		1.8		5.5	V
V_{CC2}	Supply Voltage		2.7		5.5	V
V_{CC3}	Supply Voltage		4.5		5.5	V
I_{CC}	Supply Current $V_{CC} = 5.0\text{V}$	READ at 1 MHz		0.5	2.0	mA
I_{CC}	Supply Current $V_{CC} = 5.0\text{V}$	WRITE at 1 MHz		0.5	2.0	mA
I_{SB1}	Standby Current $V_{CC} = 1.8\text{V}$	CS = 0V		0	0.1	μA
I_{SB2}	Standby Current $V_{CC} = 2.7\text{V}$	CS = 0V		6.0	10.0	μA
I_{SB3}	Standby Current $V_{CC} = 5.0\text{V}$	CS = 0V		17	30	μA
I_{LI}	Input Leakage Current	$V_{IN} = 0\text{V}$ to V_{CC}		0.1	3.0	μA
I_{LO}	Output Leakage Current	$V_{IN} = 0\text{V}$ to V_{CC}		0.1	3.0	μA
$V_{IL1}^{(1)}$	Input Low Level	$2.7\text{V} < V_{CC} < 5.5\text{V}$	-0.6		0.8	V
$V_{IH1}^{(1)}$	Input High Level		2.0		$V_{CC} + 1$	
$V_{IL2}^{(1)}$	Input Low Level	$1.8\text{V} < V_{CC} < 2.7\text{V}$	-0.6		$V_{CC} \times 0.3$	V
$V_{IH2}^{(1)}$	Input High Level		$V_{CC} \times 0.7$		$V_{CC} + 1$	
V_{OL1}	Output Low Level	$2.7\text{V} < V_{CC} < 5.5\text{V}$; $I_{OL} = 2.1\text{mA}$			0.4	V
V_{OH1}	Output High Level	$I_{OH} = -0.4\text{mA}$	2.4			
V_{OL2}	Output Low Level	$1.8\text{V} < V_{CC} < 2.7\text{V}$; $I_{OL} = 0.15\text{ mA}$			0.2	V
V_{OH2}	Output High Level	$I_{OH} = -100\mu\text{A}$	$V_{CC} - 0.2$			

Note: 1. V_{IL} and V_{IH} max are reference only and are not tested.



AC CHARACTERISTICS

Applicable over recommended operating range from:

$T_{AMB} = -40^{\circ}\text{C}$ to $+85^{\circ}\text{C}$, $V_{CC} = \text{As specified}$, $CL = 1$ TTL Gate & 100pF (unless otherwise noted).

Symbol	Parameter	Test Condition		Min	Typ	Max	Units
f_{SK}	Clock Frequency, SK	4.5V < V_{CC} < 5.5V 2.7V < V_{CC} < 5.5V 1.8V < V_{CC} < 5.5V		0 0 0		2 1 0.25	MHz
t_{SKH}	SK High Time	4.5V < V_{CC} < 5.5V 2.7V < V_{CC} < 5.5V 1.8V < V_{CC} < 5.5V		250 250 1000			ns
t_{SKL}	SK Low Time	4.5V < V_{CC} < 5.5V 2.7V < V_{CC} < 5.5V 1.8V < V_{CC} < 5.5V		250 250 1000			ns
t_{CS}	Minimum CS Low Time	4.5V < V_{CC} < 5.5V 2.7V < V_{CC} < 5.5V 1.8V < V_{CC} < 5.5V		250 250 1000			ns
t_{CSS}	CS Setup Time	Relative to SK	4.5V < V_{CC} < 5.5V 2.7V < V_{CC} < 5.5V 1.8V < V_{CC} < 5.5V	50 50 200			ns
t_{DIS}	DI Setup Time	Relative to SK	4.5V < V_{CC} < 5.5V 2.7V < V_{CC} < 5.5V 1.8V < V_{CC} < 5.5V	100 100 400			ns
t_{CSH}	CS Hold Time	Relative to SK		0			ns
t_{DIH}	DI Hold Time	Relative to SK	4.5V < V_{CC} < 5.5V 2.7V < V_{CC} < 5.5V 1.8V < V_{CC} < 5.5V	100 100 400			ns
t_{PD1}	Output Delay to "1"	AC Test	4.5V < V_{CC} < 5.5V 2.7V < V_{CC} < 5.5V 1.8V < V_{CC} < 5.5V			250 250 1000	ns
t_{PD0}	Output Delay to "0"	AC Test	4.5V < V_{CC} < 5.5V 2.7V < V_{CC} < 5.5V 1.8V < V_{CC} < 5.5V			250 250 1000	ns
t_{SV}	CS to Status Valid	AC Test	4.5V < V_{CC} < 5.5V 2.7V < V_{CC} < 5.5V 1.8V < V_{CC} < 5.5V			250 250 1000	ns
t_{DF}	CS to DO in High Impedance	AC Test CS = V_{IL}	4.5V < V_{CC} < 5.5V 2.7V < V_{CC} < 5.5V 1.8V < V_{CC} < 5.5V			100 100 400	ns
t_{WP}	Write Cycle Time		1.8V < V_{CC} < 5.5V		3	10	ms
Endurance (1)	5.0V, 25° C			1M			Write Cycles

Note: 1. This parameter is characterized and not 100% tested.



INSTRUCTION SET FOR THE AF93BC46

Instruction	SB	Op Code	Address		Data		Comments
			X8	X16	X8	X16	
READ	1	10	A ₆ – A ₀	A ₅ – A ₀			Reads data stored at specified memory location.
EWEN	1	00	11xxxxx	11xxxx			Write enable command (must be issued before any erase or write operation).
ERASE	1	11	A ₆ – A ₀	A ₅ – A ₀			Erases memory location A _n – A ₀
WRITE	1	01	A ₆ – A ₀	A ₅ – A ₀	D ₇ – D ₀	D ₁₅ – D ₀	Writes to memory location A _n – A ₀
ERAL	1	00	10xxxxx	10xxxx			Erases all memory locations. Valid only at V _{cc} = 4.5V to 5.5V
WRAL	1	00	01xxxxx	01xxxx	D ₇ – D ₀	D ₁₅ – D ₀	Writes all memory locations. Valid only at V _{cc} = 4.5V to 5.5V
EWDS	1	00	00xxxxx	00xxxx			Disables all erase or write instructions

Note: The X's in the address field represent don't care values and must be clocked.

INSTRUCTION SET FOR THE AF93BC56/66

Instruction	SB	Op Code	Address		Data		Comments
			X8	X16	X8	X16	
READ	1	10	A ₈ – A ₀	A ₇ – A ₀			Reads data stored at specified memory location.
EWEN	1	00	11xxxxxxxx	11xxxxxxxx			Write enable command (must be issued before any erase or write operation).
ERASE	1	11	A ₈ – A ₀	A ₇ – A ₀			Erase memory location A _n – A ₀
WRITE	1	01	A ₈ – A ₀	A ₇ – A ₀	D ₇ – D ₀	D ₁₅ – D ₀	Writes memory location A _n – A ₀
ERAL	1	00	10xxxxxxxx	10xxxxxxxx			Erases all memory locations. Valid only at V _{cc} = 4.5V to 5.5V
WRAL	1	00	01xxxxxxxx	01xxxxxxxx	D ₇ – D ₀	D ₁₅ – D ₀	Writes all memory locations. Valid only at V _{cc} = 4.5V to 5.5V.
EWDS	1	00	00xxxxxxxx	00xxxxxxxx			Disables all erase or write instructions

Note: The X's in the address field represent don't care values and must be clocked.



FUNCTIONAL DESCRIPTION

The AF93BC46/56/66 supports 7 different instructions, which must be clocked serially using the CS, SK and DI pins. Before sending each of these instructions, the CS pin must first be pulled high followed by a START bit (logic '1'). The next sequence includes a 2-bit Op Code and usually an 8 or 16-bit address. The next description describes the various functions in the chip.

READ (READ): The Read (READ) instruction includes the Op Code ("10") followed by the memory address location to be read. After the instruction and address is sent, the data from the memory location can be clocked out using the serial output pin DO. The data changes on the rising edge of the clock, so the falling edge can be used to strobe the output.

Note that during shifting the last address bit, the DO pin is a dummy bit (logic "0").

ERASE/WRITE (EWEN): When the chip is first powered-on, no erase or write instructions can be issued. Only when the Erase/Write Enable (EWEN) instruction is sent will the system be allowed to write to the chip. The EWEN command only needs to be issued once after being powered-on. To disable the chip again, the Erase/Write Disable (EWDS) command can be used.

ERASE (ERASE): The Erase (ERASE) instruction clears the designated memory location to a logical '1' state. After the Op Code and address location is inputted, the chip will enter into an erase cycle. When the cycle completes, the chip will automatically enter into standby mode.

WRITE (WRITE): The Write (WRITE) instruction is used to write to a specific memory location. If word mode (x16) is selected, then 16 bits of data will be written into the location. If byte mode (x8) is chosen, then 8 bits of data will be written into the location. The write cycle will begin automatically after the 8 or 16 bits are shifted into the chip.

ERASE ALL (ERAL): The Erase All (ERAL) instruction is primarily used for testing purposes and only functions when $V_{cc}=4.5\text{ V}$ to 5.5 V . This instruction will clear the entire memory array to '1'.

WRITE ALL (WRAL): The Write All (WRAL) instruction will program the entire memory array according to the 8 or 16-bit data pattern provided. The instruction will only be valid when $V_{cc}=4.5\text{ V}$ to 5.5 V .

ERASE/WRITE DISABLE (EWDS): The Erase/Write Disable (EWDS) instruction blocks any kind of erase or program operations from modifying the contents of the memory array. This instruction should be executed after erasing or programming to prevent accidental data loss.

Note also that the READ instruction will operate regardless of whether the chip is disabled from program and write operations.



Ready/Busy

To determine whether the chip has completed an erase or write operation, the CS signal can be pulled LOW for a minimum of 250 ns (t_{cs}) and then pulled back HIGH to enter Ready/Busy mode. If the chip is currently in the programming cycle, t_{WP} , then the DO pin will go low (logical "0"). When the write cycle completes, the DO pin is pulled high (logical "1") to indicate that the part can receive another instruction. Note that the Ready/Busy polling cannot be done if the chip has already finished and returned back to standby mode.



TIMING DIAGRAMS

Synchronous Data Timing

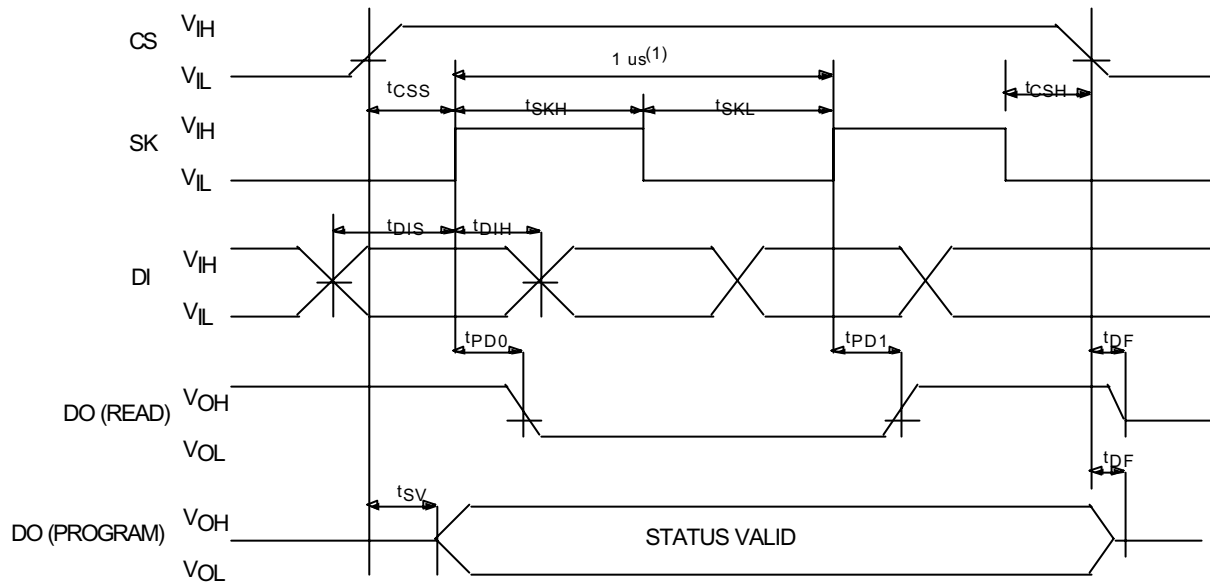

Note (1): This is the minimum SK period.

Organization Key for Timing Diagrams

I/O	AF93BC46(1K)		AF93BC56(2K)		AF93BC66(4K)	
	X8	X16	X8	X16	X8	X16
A_N	A_6	A_5	$A_8^{(1)}$	$A_7^{(2)}$	A_8	A_7
D_N	D_7	D_{15}	D_7	D_{15}	D_7	D_{15}

Notes:

- A_8 is a DON'T CARE value, but the extra clock is required.
- A_7 is a DON'T CARE value, but the extra clock is required.



READ TIMING

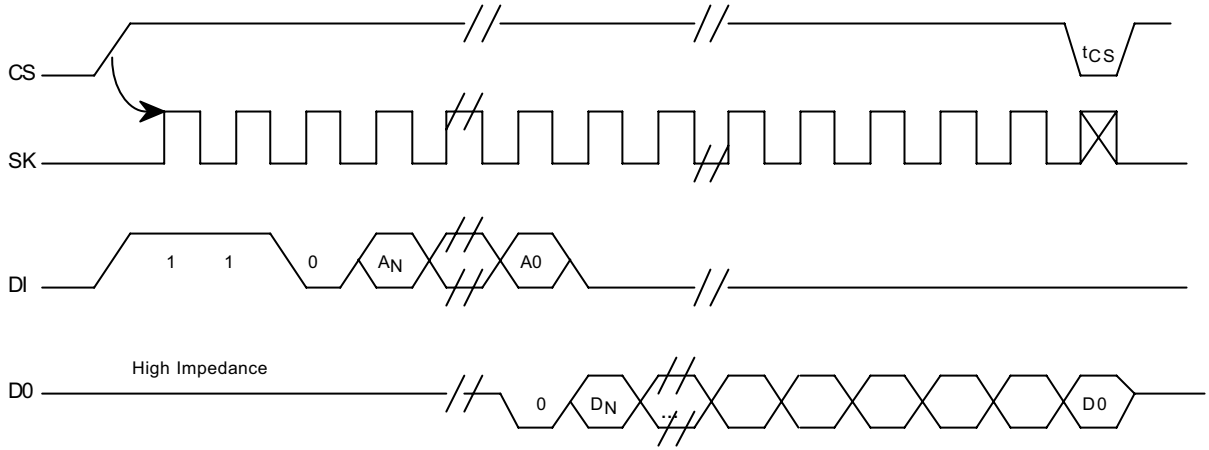

EWEN TIMING

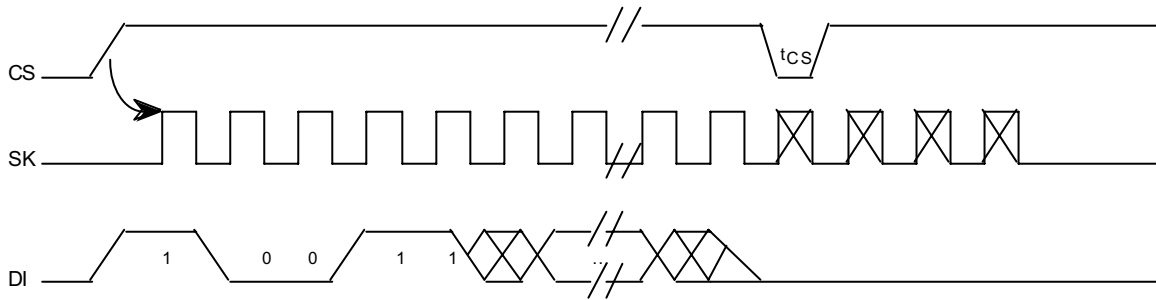



EWDS TIMING

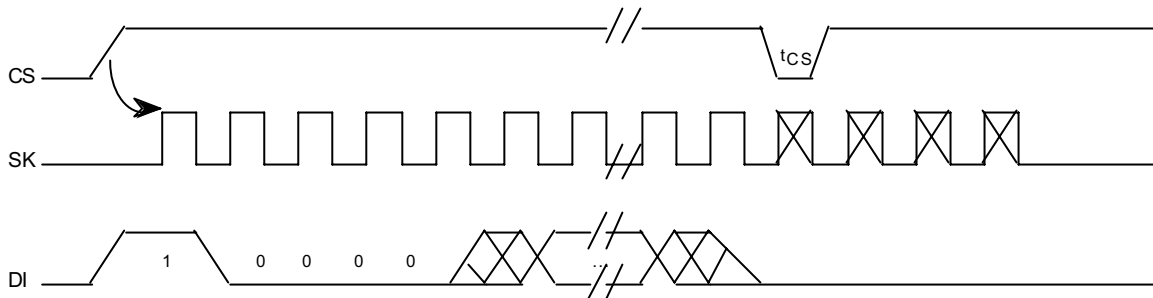

WRITE TIMING

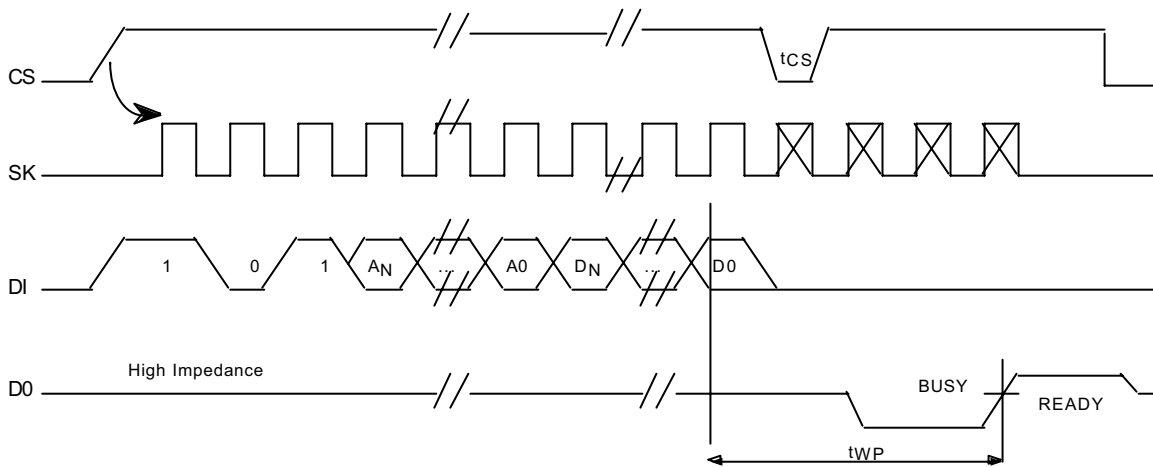

WRAL TIMING⁽¹⁾

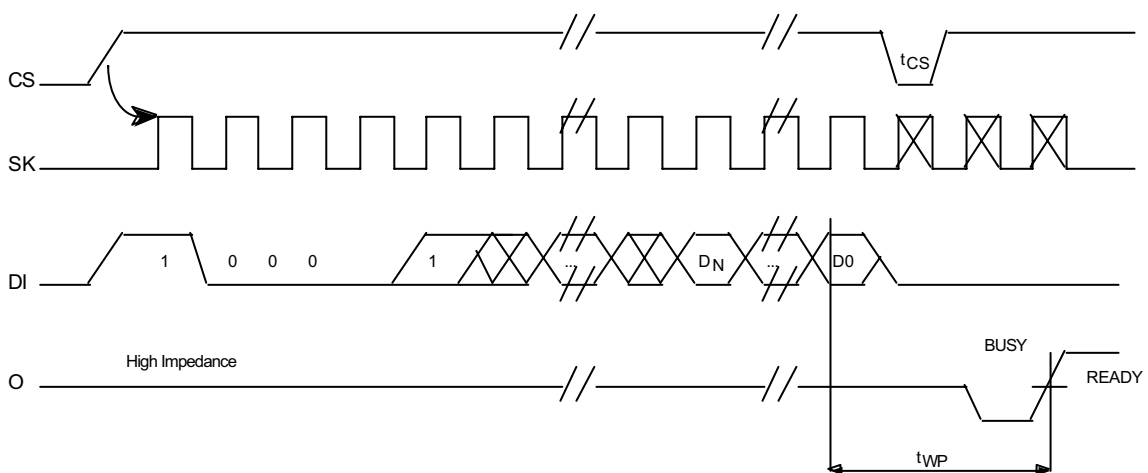

(1) Valid only at $V_{CC} = 4.5V$ to $5.5V$



ERASE TIMING

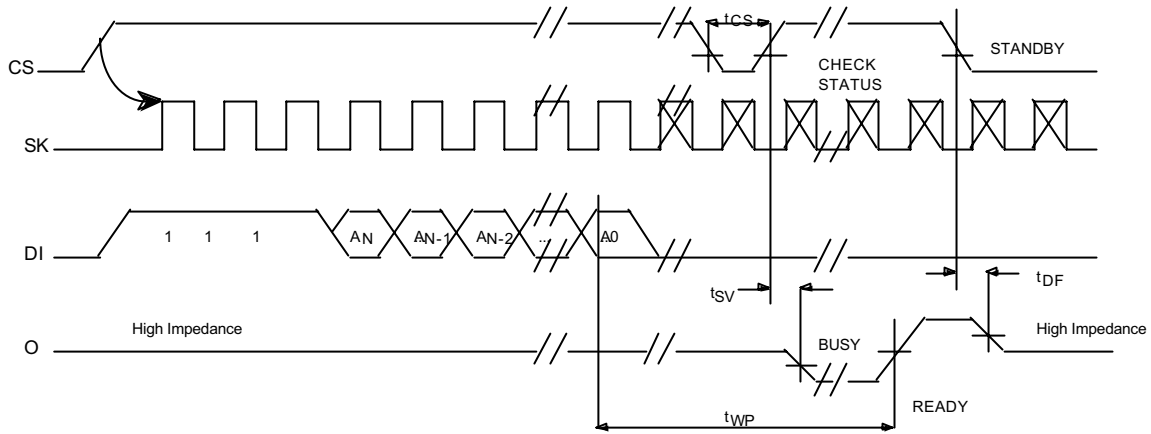

ERASE TIMING¹⁾

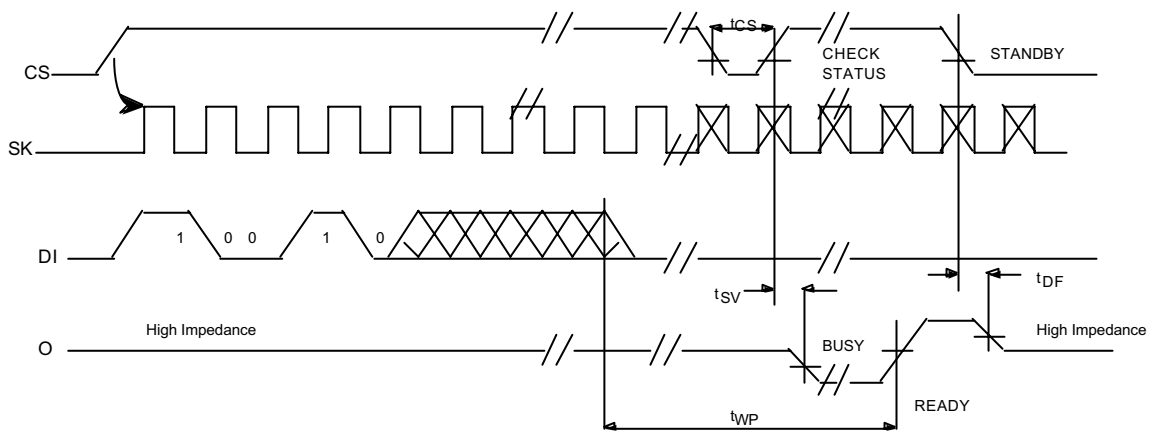

(1) Valid only at $V_{CC} = 4.5V$ to $5.5V$



AF93BC46 Ordering Information

Ordering Code	Package	Operating Ranges
AF93BC46 – P I	P	Lead free
AF93BC46 – S I	S	Industrial
AF93BC46 – T I	T	(-40°C to +85°C)

AF93BC56 Ordering Information

Ordering Code	Package	Operating Ranges
AF93BC56 – P I	P	Lead free
AF93BC56 – S I	S	Industrial
AF93BC56 – T I	T	(-40°C to +85°C)

AF93BC66 Ordering Information

Ordering Code	Package	Operating Ranges
AF93BC66 – P I	P	Lead free
AF93BC66 – S I	S	Industrial
AF93BC66 – T I	T	(-40°C to +85°C)

Package Type	
P	8-pin, 0.300" Wide, Plastic Dual Inline Package (PDIP)
S	8-pin, 0.150" Wide, Plastic Gull Wing Small Outline (JEDEC SOIC)
T	8-pin, 0.170" Wide, Thin Shrink Small Outline Package (TSSOP)



PRODUCT ORDERING INFORMATION

	AF93	BC	aa	-Y	Z
Device Type					
AF93					
Supply Voltage					
BC = 1.8V to 5.5V					
Device Function					
46 = 1 Kbit (128 x 8 or 64 x 16)					
56 = 2 Kbit (256 x 8 or 128 x 16)					
66 = 4 Kbit (512 x 8 or 256 x 16)					
Package					
P = PDIP					
S = SOIC					
T = TSSOP					
Temperature					
I = Industrial (-40°C ~ 85°C)					



PACKAGING INFORMATION

8-pin SOIC

TOP VIEW

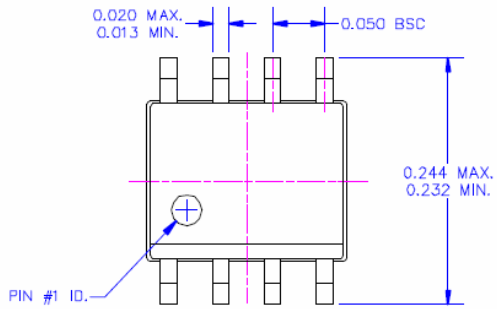

FRONT VIEW

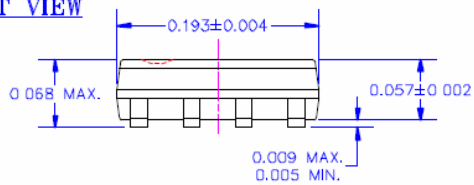

SIDE VIEW

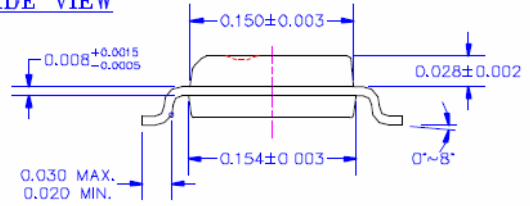

TITLE NAME		8L SOIC MATRIX PACKAGE OUTLINE DRAWING			
SCALE: 9:1	DATE	TOL	MAT'L: N/A		
DWG:		xx N/A	SURF.FIN: N/A		
CHKD:		xxx N/A	HARDNESS: N/A		
APPD:		xxxx N/A	Drawing # PO-S0-8-001 REV		
		arg N/A	1 OF 1	REF.	N/A F
		fra N/A			



8-pin PDIP

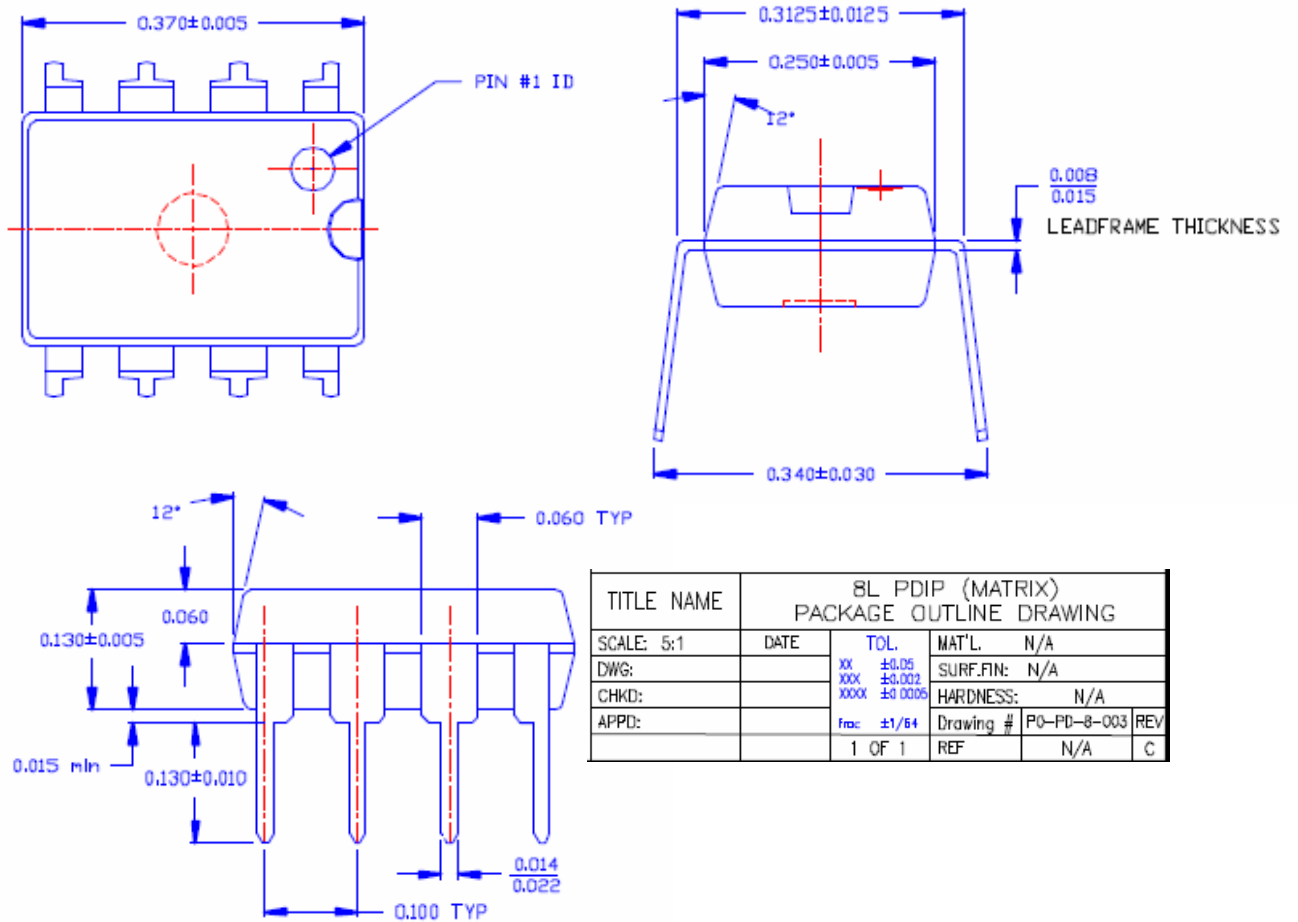

Note:

1. All package dimensions do not include mold flash. Mold flash shall not exceed 5 mils.
2. Lead dimensions does not include protrusions. Lead protrusions does not exceed 10 mils and lead intrusion is not allowed.
3. All dimensions are in inches.



8-pin TSSOP

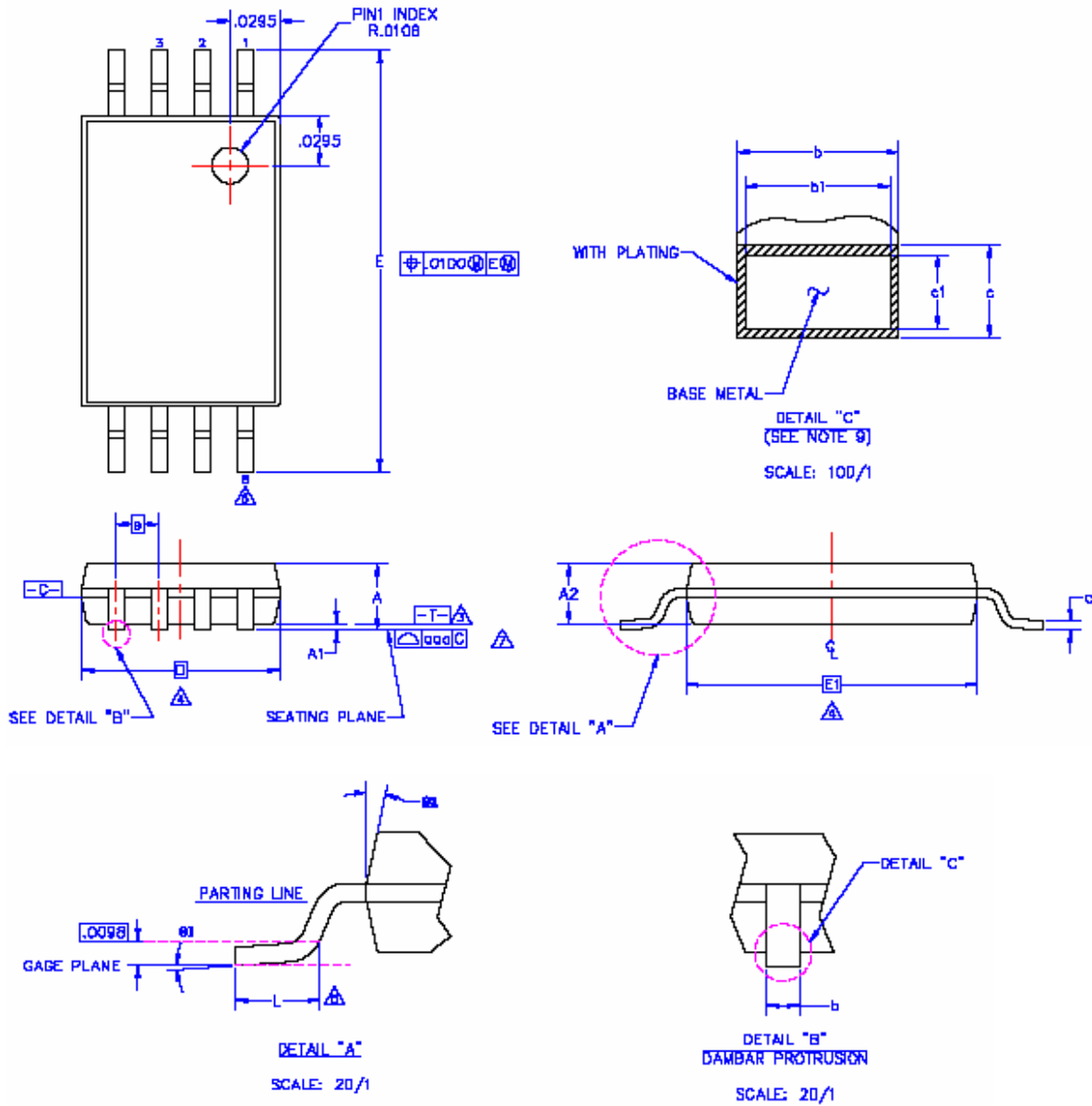

(continued on next page)



SYMBOL	DIMENSION					
	JEDEC STANDARD					
	IN MM			IN INCH		
	MIN.	NOM.	MAX.	MIN.	NOM.	MAX.
A	-	-	1.20	-	-	0.0472
A1	0.05	-	0.15	0.0020	-	0.0059
A2	0.80	1.00	1.05	0.0315	0.0394	0.0413
b	0.19	-	0.30	0.0075	-	0.0118
b1	0.19	0.22	0.25	0.0075	0.0087	0.0098
c	0.09	-	0.20	0.0035	-	0.0079
c1	0.09	-	0.16	0.0035	-	0.0063
D	2.90	3.00	3.10	0.1142	0.1181	0.1220
e	0.85 BSC			0.0256 BSC		
F	6.4 BSC			0.2520 BSC		
E1	4.30	4.40	4.50	0.1693	0.1732	0.1772
L	0.45	0.60	0.75	0.0177	0.0236	0.0295
Ø1	Ø	-	Ø	Ø	-	Ø
Ø2	12°REF			12°REF		
Ø3	0.10			0.0039		

TITLE NAME		8L TSSOP PACKAGE OUTLINE DRAWING			
SCALE: 10:1	DATE	TOL N/A	MAT'L: N/A		
DWG:			SURF.FIN: N/A		
CHKD:			HARDNESS: N/A		
APPD:			DG NO	PO-TS-8-001	REV
		1 OF 1	REF.	N/A	B



REVISIONS

Version Number	Description	Page	Date
1.04	Add lead free description	1, 12	10/15/2007

Aplus Flash Technology, Inc.
780 Montague Expressway, Suite 401
San Jose, CA 95131
www.aplusflash.com

Note the following details:

Information contained in this publication regarding device applications and the like is intended through suggestion only and may be superseded by updates. Aplus takes no responsibility to ensure that the application meets the required specifications. No representation or warranty is given and no liability is assumed by Aplus Flash Technology Incorporated with respect to the accuracy or use of such information, or infringement of patents or other intellectual property rights arising from such use or otherwise. Use of Aplus' products as critical components in life support systems is not authorized except with express written approval by Aplus. No licenses are conveyed, implicitly or otherwise, under any intellectual property rights.

Aplus makes no warranty, representation or guarantee, express or implied, regarding the suitability of its IP or products for any particular purpose, nor that the use of its products or IP will not infringe its intellectual property rights or the rights of third parties with respect to particular use or application and specifically disclaims any and all liability arising out of any such use or application, including but not limited to , consequential or incidental damages. Aplus' products and IP are not designed, intended or authorized for use as components in systems intended for surgical implant into the body, or other applications intended to support or sustain life, or for any other application and specifically disclaims any and all liability arising out of any such use or application, including but not limited to, consequential or incidental damages.