



STD2HNK60Z, STD2HNK60Z-1 STF2HNK60Z, STD2HNK60Z-AP

N-channel 600 V, 4.4 Ω , 2 A Zener-protected SuperMESH™
Power MOSFET in TO-92-TO-220FP-DPAK-IPAK packages

Datasheet — production data

Features

Order codes	V _{DSS}	R _{DS(on)} max.	I _D	P _{TOT}
STD2HNK60Z	600 V	< 4.8 Ω	2 A	45 W
STD2HNK60Z-1	600 V	< 4.8 Ω	2 A	45 W
STF2HNK60Z	600 V	< 4.8 Ω	2 A	20 W
STQ2HNK60ZR-AP	600 V	< 4.8 Ω	0.5 A	3 W

- Gate charge minimized
- 100% avalanche tested
- Extremely high dv/dt capability
- ESD improved capability
- New high voltage benchmark

Applications

- Switching applications

Description

These devices are N-channel Zener-protected Power MOSFETs developed using STMicroelectronics' SuperMESH™ technology, achieved through optimization of ST's well established strip-based PowerMESH™ layout. In addition to a significant reduction in on-resistance, this device is designed to ensure a high level of dv/dt capability for the most demanding applications.

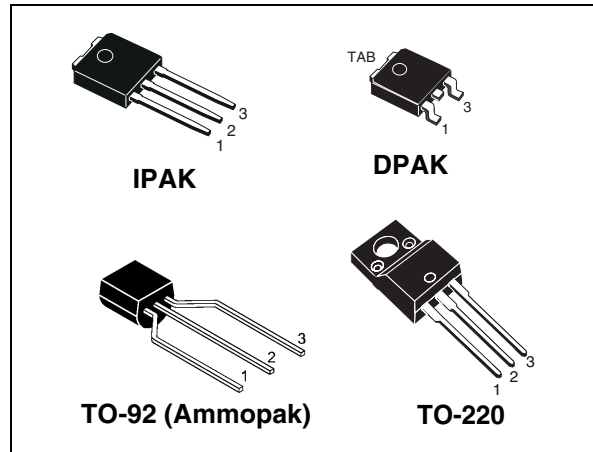

Figure 1. Internal schematic diagram

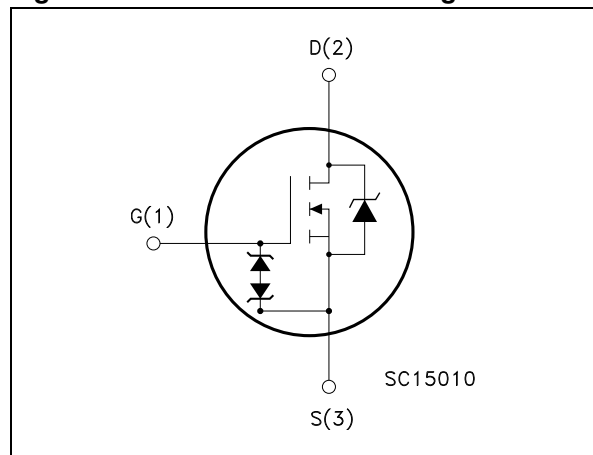

Table 1. Device summary

Order codes	Marking	Package	Packaging
STD2HNK60Z	D2HNK60Z	DPAK	Tape and reel
STD2HNK60Z-1	D2HNK60Z	IPAK	Tube
STF2HNK60Z	F2HNK60Z	TO-220FP	Tube
STQ2HNK60ZR-AP	Q2HNK60ZR	TO-92	Ammopak

Contents

1	Electrical ratings	3
2	Electrical characteristics	4
2.1	Electrical characteristics (curves)	6
3	Test circuits	9
4	Package mechanical data	10
5	Packaging mechanical data	19
6	Revision history	21

1 Electrical ratings

Table 2. Absolute maximum ratings

Symbol	Parameter	Value			Unit
		IPAK,DPAK	TO-220FP	TO-92	
V_{DS}	Drain-source voltage	600			V
V_{GS}	Gate-source voltage	±30			V
I_D	Drain current (continuous) at $T_C = 25\text{ °C}$	2.0	2.0	0.5	A
I_D	Drain current (continuous) at $T_C=100\text{ °C}$	1.26	1.26	0.32	A
$I_{DM}^{(1)}$	Drain current (pulsed)	8	8	2	A
P_{TOT}	Total dissipation at $T_C = 25\text{ °C}$	45	20	3	W
	Derating factor	0.36	0.16	0.025	W/°C
$V_{ESD(G-S)}$	Gate source ESD (HBM-C=100 pF, R=1.5 kΩ)	2000			V
V_{ISO}	Insulation withstand voltage (DC)		2500		V
$dv/dt^{(2)}$	Peak diode recovery voltage slope	4.5			V/ns
T_J T_{stg}	Operating junction temperature Storage temperature	- 55 to 150			°C
T_I	Maximum lead temperature for soldering purpose	300		260	°C

1. Pulse width limited by safe operating area.
2. $I_{SD} \leq 2\text{ A}$, $di/dt \leq 200\text{ A}/\mu\text{s}$, $V_{DD} = 80\%V_{(BR)DSS}$.

Table 3. Thermal data

Symbol	Parameter	IPAK/DPAK	TO-220FP	TO-92	Unit
$R_{thj-case}$	Thermal resistance junction-case max	2.77	6.25		°C/W
$R_{thj-amb}$	Thermal resistance junction-ambient max	100	62.5	120	°C/W
$R_{thj-lead}$	Thermal resistance junction-lead max			40	°C/W

Table 4. Avalanche data

Symbol	Parameter	Value	Unit
I_{AR}	Avalanche current, repetitive or not repetitive (pulse width limited by T_{jmax})	2	A
E_{AS}	Single pulse avalanche energy (starting $T_j = 25\text{ °C}$, $I_D=I_{AR}$, $V_{DD} = 50\text{ mV}$)	120	mJ

2 Electrical characteristics

($T_{CASE} = 25\text{ °C}$ unless otherwise specified)

Table 5. On/off states

Symbol	Parameter	Test conditions	Min.	Typ.	Max.	Unit
$V_{(BR)DSS}$	Drain-source breakdown voltage	$I_D = 1\text{ mA}$, $V_{GS} = 0$	600			V
I_{DSS}	Zero gate voltage drain current ($V_{GS} = 0$)	$V_{DS} = 600\text{ V}$, $V_{DS} = 600\text{ V}$, $T_c = 125\text{ °C}$			1 50	μA μA
I_{GSS}	Gate body leakage current ($V_{DS} = 0$)	$V_{GS} = \pm 20\text{ V}$			± 10	μA
$V_{GS(th)}$	Gate threshold voltage	$V_{DS} = V_{GS}$, $I_D = 50\text{ }\mu\text{A}$	3	3.75	4.5	V
$R_{DS(on)}$	Static drain-source on-resistance	$V_{GS} = 10\text{ V}$, $I_D = 1\text{ A}$		4.4	4.8	Ω

Table 6. Dynamic

Symbol	Parameter	Test conditions	Min.	Typ.	Max.	Unit
$g_{fs}^{(1)}$	Forward transconductance	$V_{DS} = 15\text{ V}$, $I_D = 1\text{ A}$	-	1.5		S
C_{iss}	Input capacitance	$V_{DS} = 25\text{ V}$, $f = 1\text{ MHz}$, $V_{GS} = 0$	-	280		μF
C_{oss}	Output capacitance			38		μF
C_{rss}	Reverse transfer capacitance			7		μF
$C_{oss\ eq}^{(2)}$	Equivalent output capacitance	$V_{GS} = 0$, $V_{DS} = 0\text{ to }480\text{ V}$	-	30		μF
Q_g	Total gate charge	$V_{DD} = 480\text{ V}$, $I_D = 2\text{ A}$	-	11	15	nC
Q_{gs}	Gate-source charge	$V_{GS} = 10\text{ V}$		2.25		nC
Q_{gd}	Gate-drain charge	(see Figure 19)		6		nC

1. Pulsed: pulse duration=300 μs , duty cycle 1.5%

2. $C_{oss\ eq}$ is defined as a constant equivalent capacitance giving the same charging time as C_{oss} when V_{DS} increases from 0 to 80% V_{DSS}

Table 7. Switching times

Symbol	Parameter	Test conditions	Min.	Typ.	Max.	Unit
$t_{d(on)}$	Turn-on delay time	$V_{DD}=300\text{ V}$, $I_D=1\text{ A}$, $R_G=4.7\ \Omega$, $V_{GS}=10\text{ V}$ <i>(see Figure 18)</i>	-	10	-	ns
t_r	Rise time		-	30	-	ns
$t_{d(off)}$	Turn-off delay time		-	23	-	ns
t_f	Fall time		-	50	-	ns

Table 8. Source drain diode

Symbol	Parameter	Test conditions	Min.	Typ.	Max.	Unit
I_{SD}	Source-drain current		-		2	A
$I_{SDM}^{(1)}$	Source-drain current (pulsed)				8	A
$V_{SD}^{(2)}$	Forward on voltage	$I_{SD} = 2\text{ A}$, $V_{GS} = 0$	-		1.3	V
t_{rr}	Reverse recovery time	$I_{SD}=2\text{ A}$, $di/dt = 100\text{ A}/\mu\text{s}$, $V_{DD}=20\text{ V}$	-	178		ns
Q_{rr}	Reverse recovery charge			445		nC
I_{RRM}	Reverse recovery current			5		A
t_{rr}	Reverse recovery time	$I_{SD}=2\text{ A}$, $di/dt = 100\text{ A}/\mu\text{s}$, $V_{DD}=20\text{ V}$, $T_j=150\text{ }^\circ\text{C}$	-	200		ns
Q_{rr}	Reverse recovery charge			500		nC
I_{RRM}	Reverse recovery current			5		A

1. Pulse width limited by safe operating area

2. Pulsed: pulse duration=300 μs , duty cycle 1.5%

2.1 Electrical characteristics (curves)

Figure 2. Safe operating area for TO-92

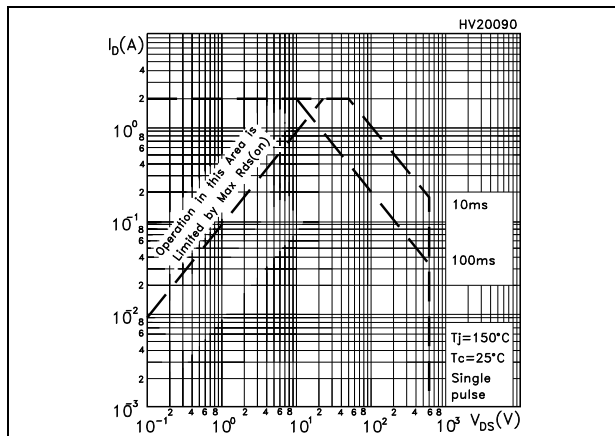

Figure 3. Thermal impedance for TO-92

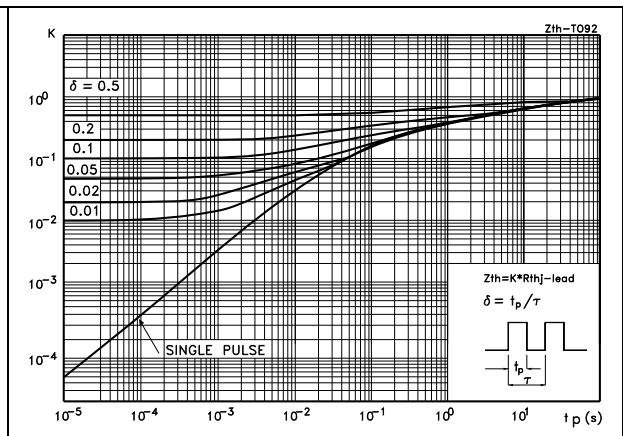

Figure 4. Safe operating area for TO-220FP

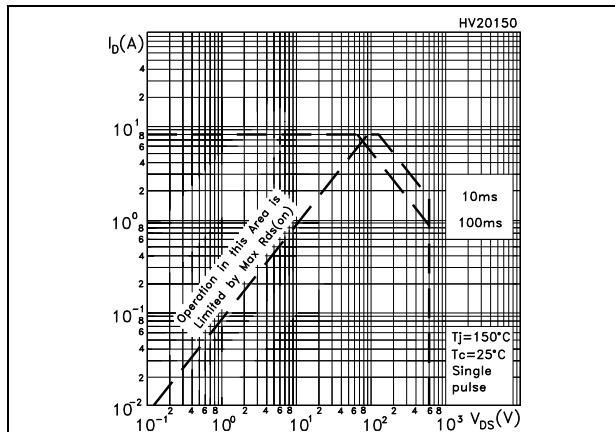

Figure 5. Thermal impedance for TO-220FP

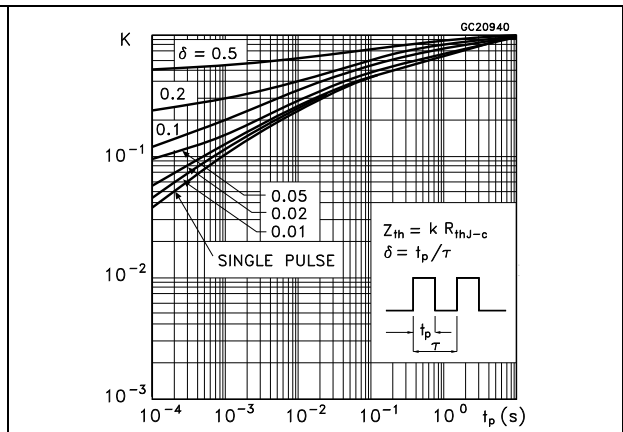

Figure 6. Safe operating area for IPAK/DPAK

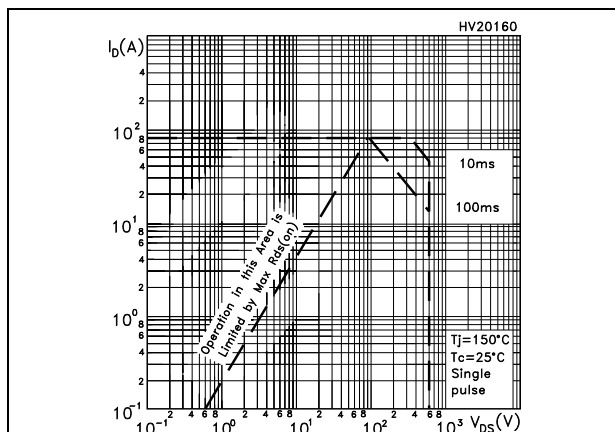

Figure 7. Thermal impedance for IPAK/DPAK

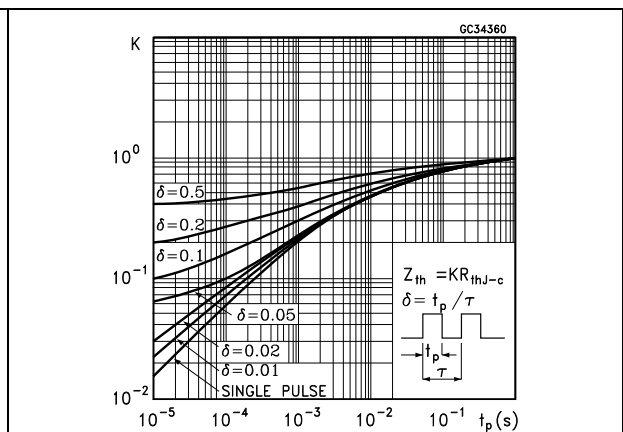

Figure 8. Output characteristics

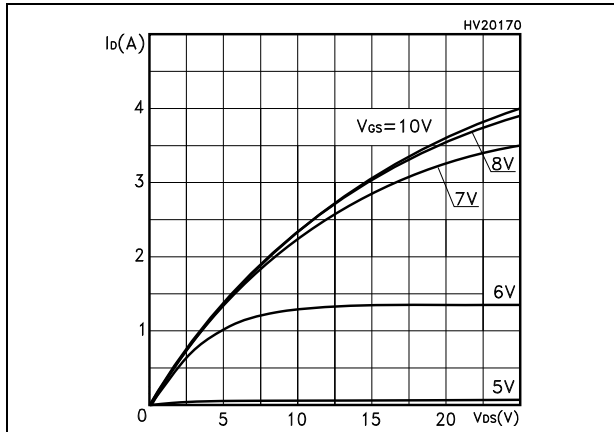

Figure 9. Transfer characteristics

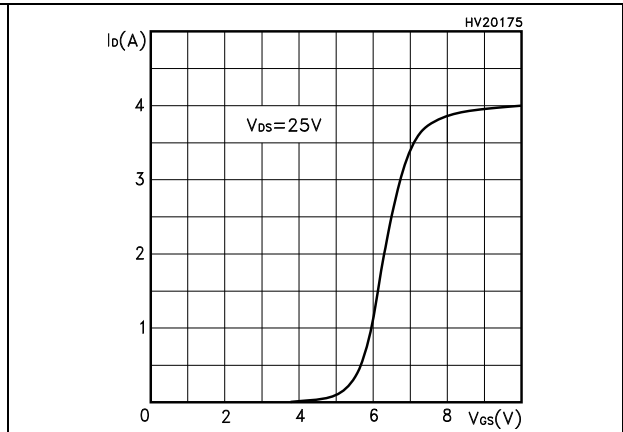

Figure 10. Normalized B_{VDSS} vs temperature

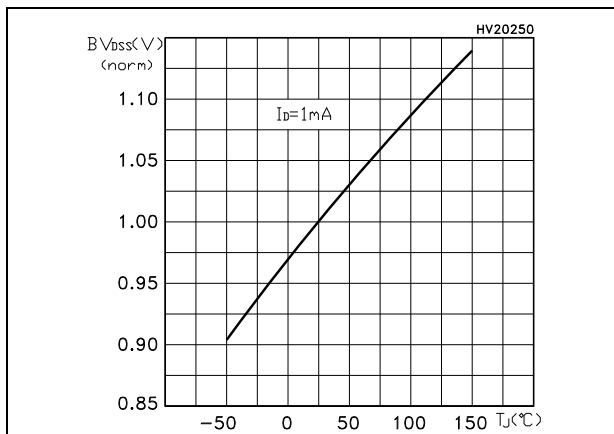

Figure 11. Static drain-source on-resistance

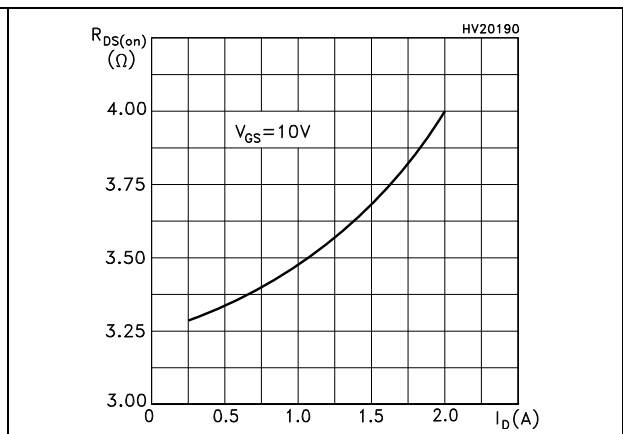

Figure 12. Gate charge vs gate-source voltage

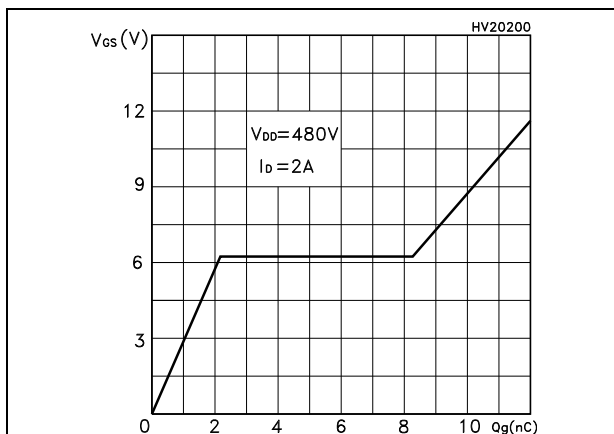

Figure 13. Capacitance variations

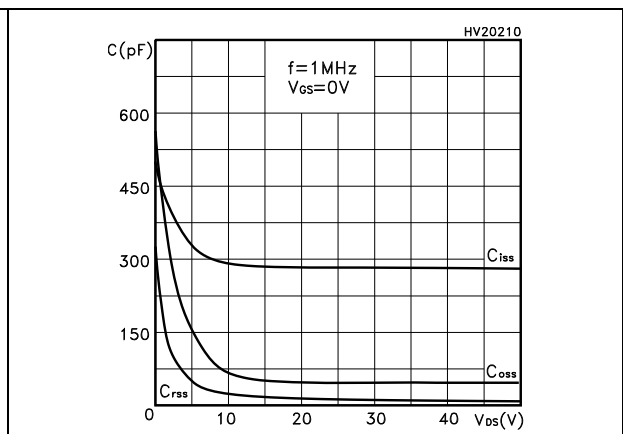

Figure 14. Normalized gate threshold voltage vs temperature

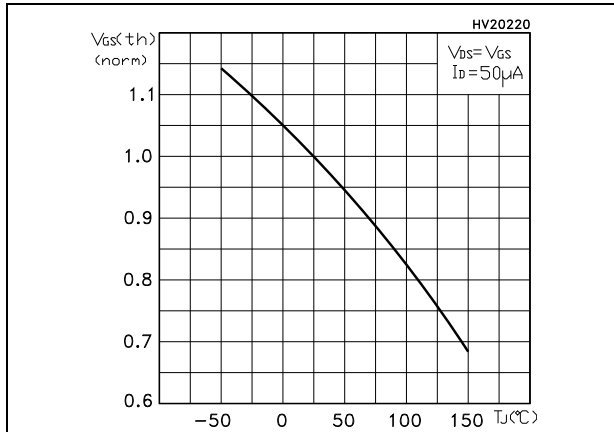

Figure 15. Normalized on-resistance vs temperature

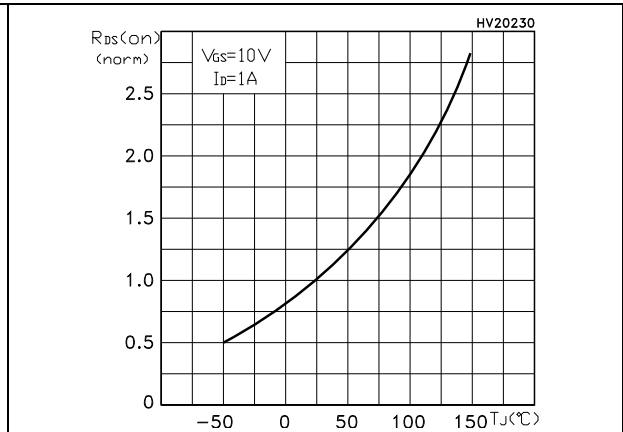

Figure 16. Source-drain diode forward characteristics

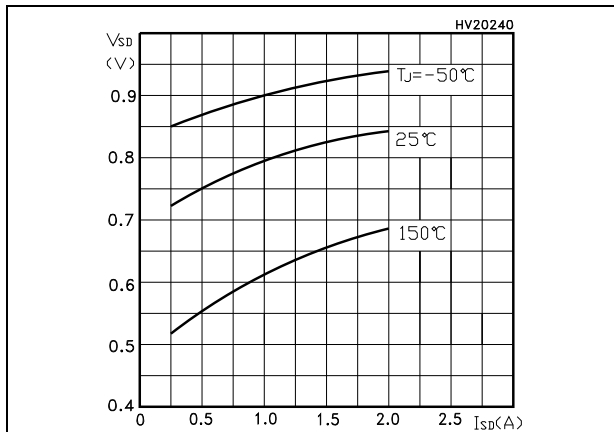
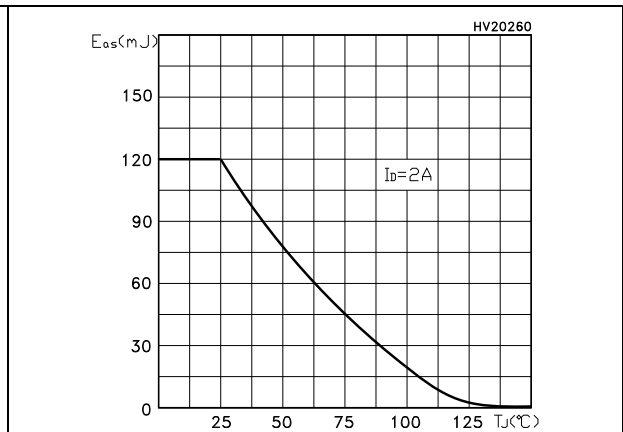
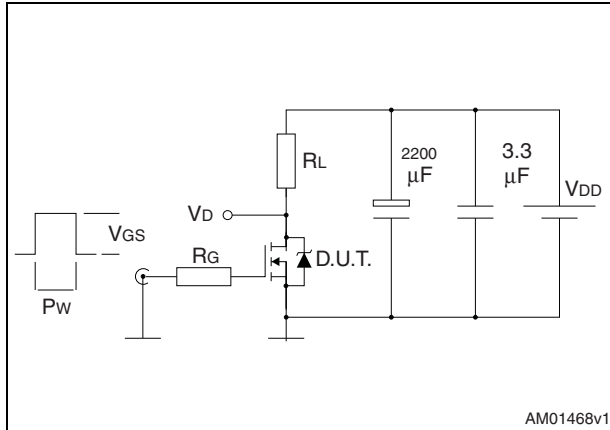

Figure 17. Maximum avalanche energy vs temperature



3 Test circuits

Figure 18. Switching times test circuit for resistive load



AM01468v1

Figure 19. Gate charge test circuit

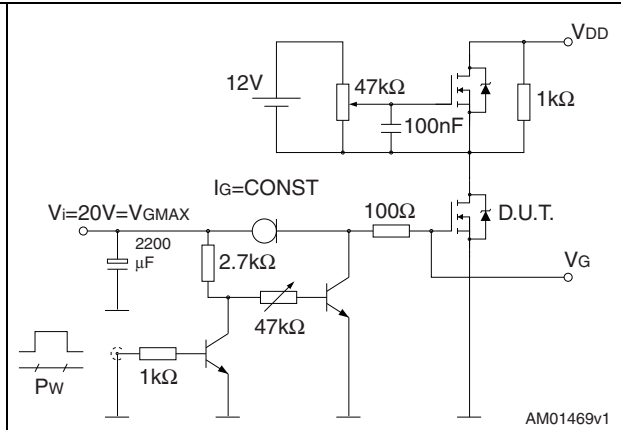

AM01469v1

Figure 20. Test circuit for inductive load switching and diode recovery times

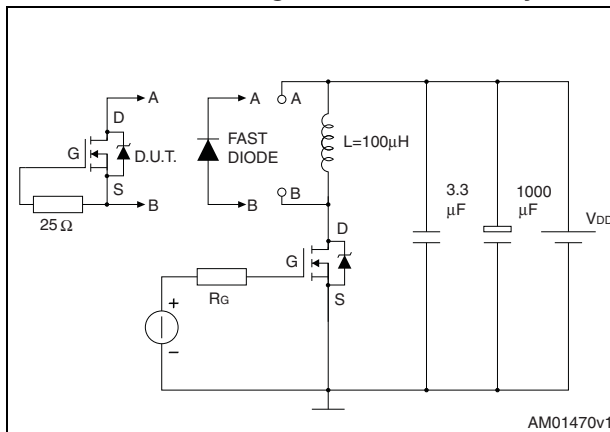

AM01470v1

Figure 21. Unclamped inductive load test circuit

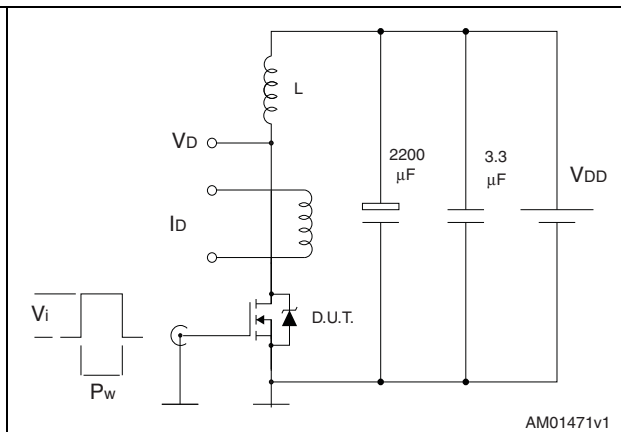

AM01471v1

Figure 22. Unclamped inductive waveform

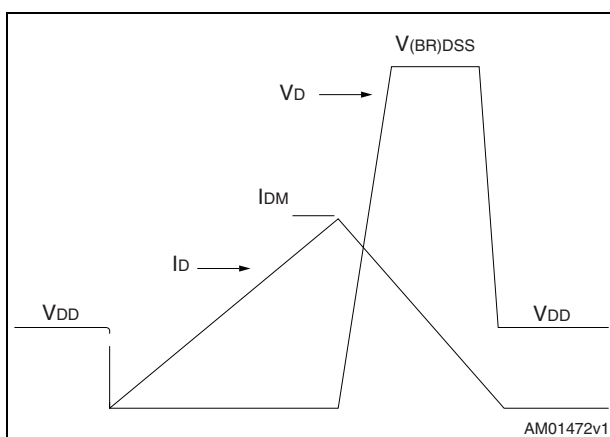

AM01472v1

Figure 23. Switching time waveform

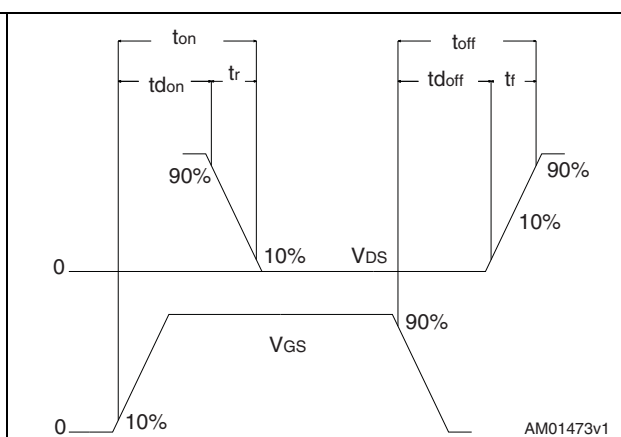

AM01473v1

4 Package mechanical data

In order to meet environmental requirements, ST offers these devices in different grades of ECOPACK® packages, depending on their level of environmental compliance. ECOPACK® specifications, grade definitions and product status are available at: www.st.com. ECOPACK is an ST trademark.

Table 9. IPAK (TO-251) mechanical data

DIM.	mm.		
	min.	typ	max.
A	2.20		2.40
A1	0.90		1.10
b	0.64		0.90
b2			0.95
b4	5.20		5.40
B5		0.3	
c	0.45		0.60
c2	0.48		0.60
D	6.00		6.20
E	6.40		6.60
e		2.28	
e1	4.40		4.60
H		16.10	
L	9.00		9.40
L1	0.80		1.20
L2		0.80	1.00
V1		10 °	

Figure 24. IPAK (TO-251) drawing

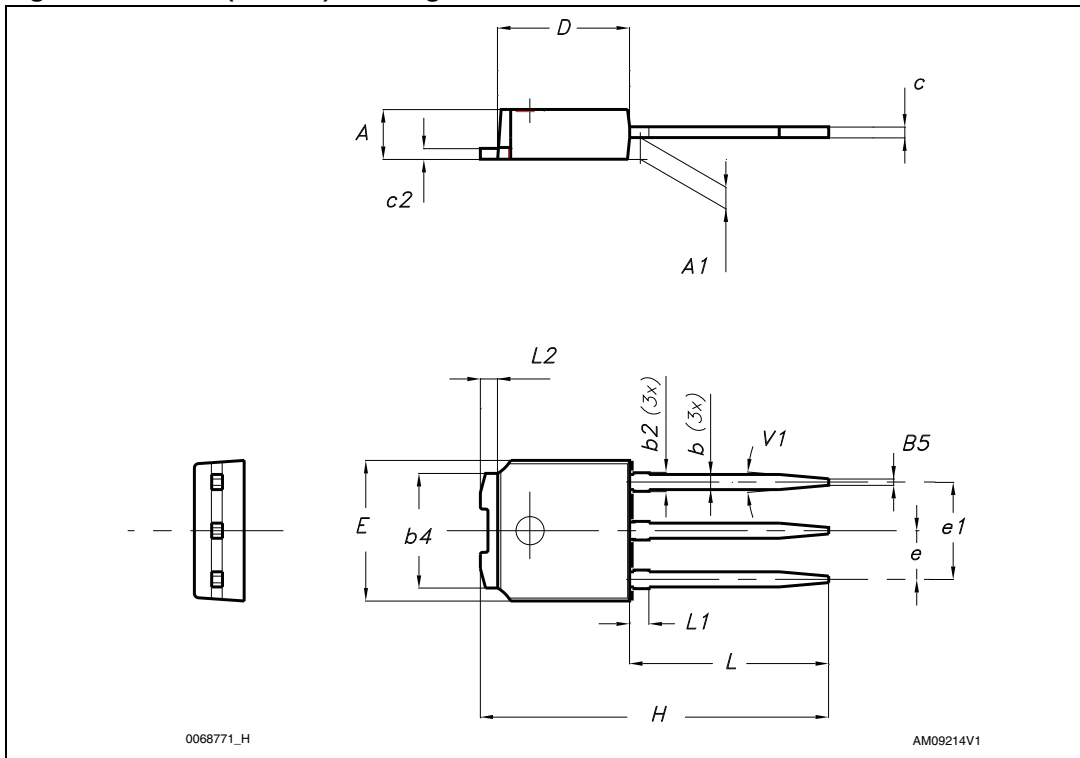

Table 10. DPAK (TO-252) mechanical data

Dim.	mm		
	Min.	Typ.	Max.
A	2.20		2.40
A1	0.90		1.10
A2	0.03		0.23
b	0.64		0.90
b4	5.20		5.40
c	0.45		0.60
c2	0.48		0.60
D	6.00		6.20
D1		5.10	
E	6.40		6.60
E1		4.70	
e		2.28	
e1	4.40		4.60
H	9.35		10.10
L	1		1.50
L1		2.80	
L2		0.80	
L4	0.60		1
R		0.20	
V2	0°		8°

Figure 25. DPAK (TO-252) drawing

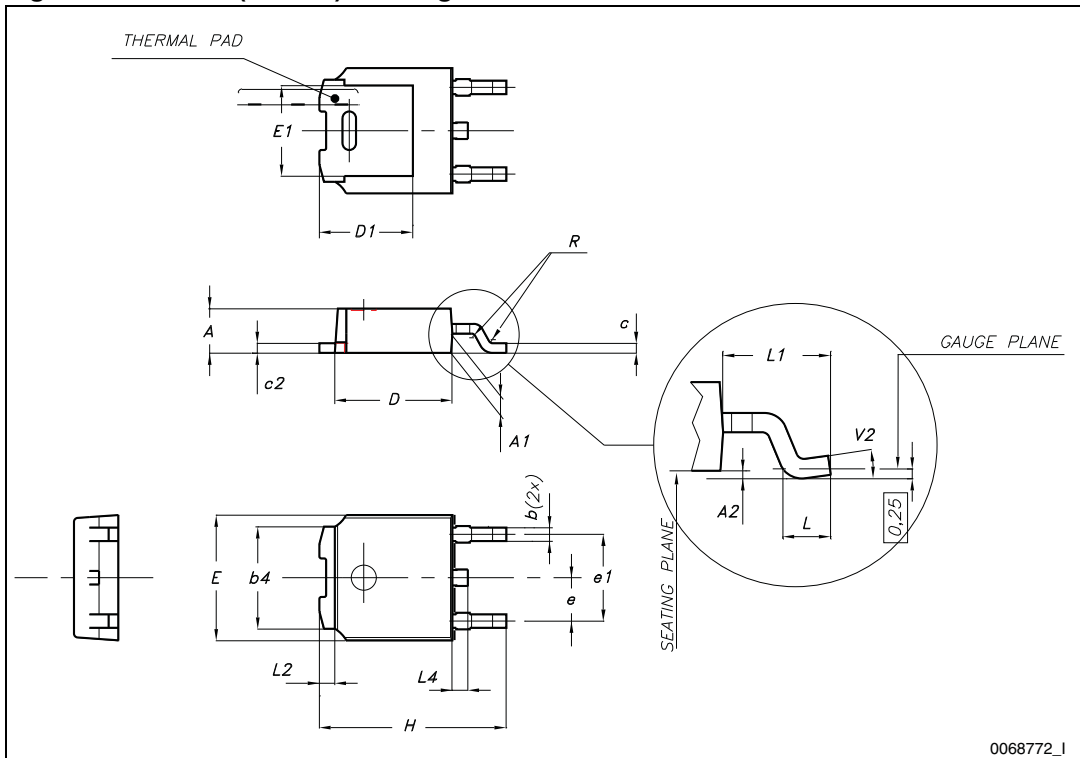
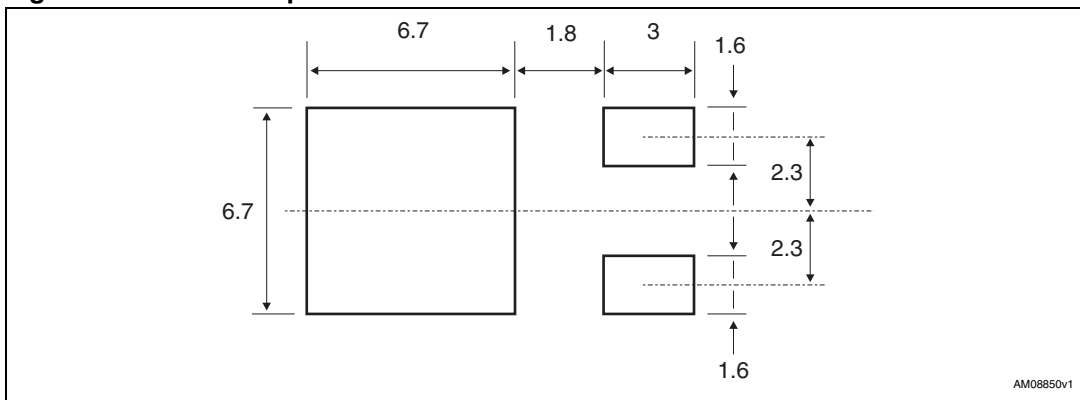

Figure 26. DPAK footprint^(a)



a. All dimensions are in millimeters

Table 11. TO-220FP mechanical data

Dim.	mm		
	Min.	Typ.	Max.
A	4.4		4.6
B	2.5		2.7
D	2.5		2.75
E	0.45		0.7
F	0.75		1
F1	1.15		1.70
F2	1.15		1.70
G	4.95		5.2
G1	2.4		2.7
H	10		10.4
L2		16	
L3	28.6		30.6
L4	9.8		10.6
L5	2.9		3.6
L6	15.9		16.4
L7	9		9.3
Dia	3		3.2

Figure 27. TO-220FP drawing

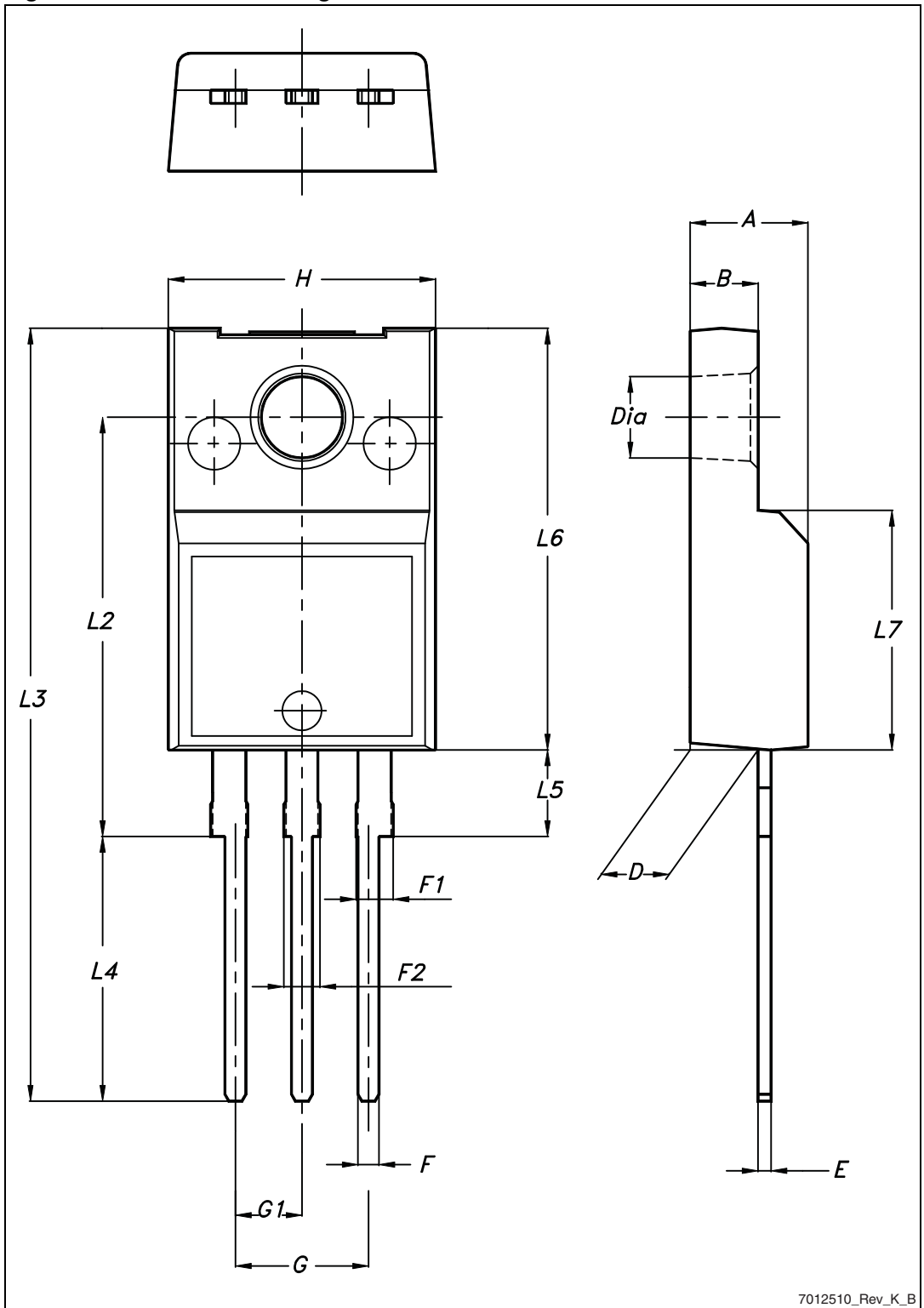

7012510_Rev_K_B

Table 12. TO-92 ammopack mechanical data

Dim.	mm		
	Min.	Typ.	Max.
A1			4.80
T			3.80
T1			1.60
T2			2.30
d			0.48
P0	12.50	12.70	12.90
P2	5.65	6.35	7.05
F1, F2	2.44	2.54	2.94
F3	4.98	5.08	5.48
delta H	-2.00		2.00
W	17.50	18.00	19.00
W0	5.70	6.00	6.30
W1	8.50	9.00	9.25
W2			0.50
H	18.50		20.50
H3	0.5	1	1.5
H0	15.50	16.00	16.50
H1			25.00
D0	3.80	4.00	4.20
t			0.90
L			11.00
l1	3.00		
delta P	-1.00		1.00

Figure 28. TO-92 ammopack mechanical data drawing

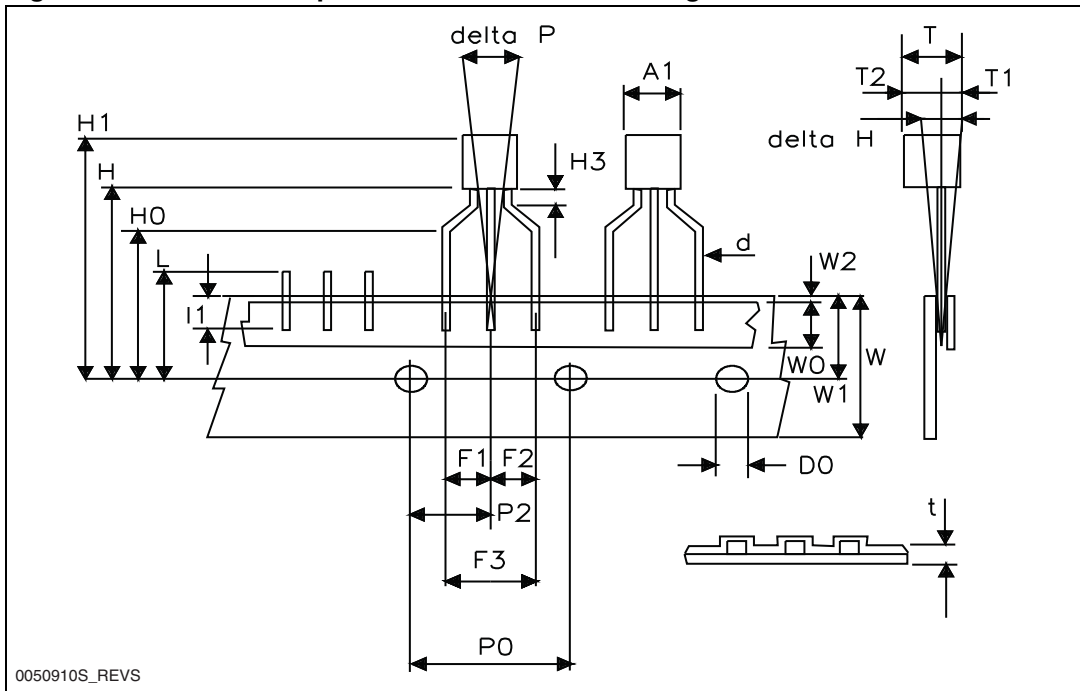

5 Packaging mechanical data

Table 13. DPAK (TO-252) tape and reel mechanical data

Tape			Reel		
Dim.	mm		Dim.	mm	
	Min.	Max.		Min.	Max.
A0	6.8	7	A		330
B0	10.4	10.6	B	1.5	
B1		12.1	C	12.8	13.2
D	1.5	1.6	D	20.2	
D1	1.5		G	16.4	18.4
E	1.65	1.85	N	50	
F	7.4	7.6	T		22.4
K0	2.55	2.75			
P0	3.9	4.1	Base qty.		2500
P1	7.9	8.1	Bulk qty.		2500
P2	1.9	2.1			
R	40				
T	0.25	0.35			
W	15.7	16.3			

Figure 29. Tape for DPAK (TO-252)

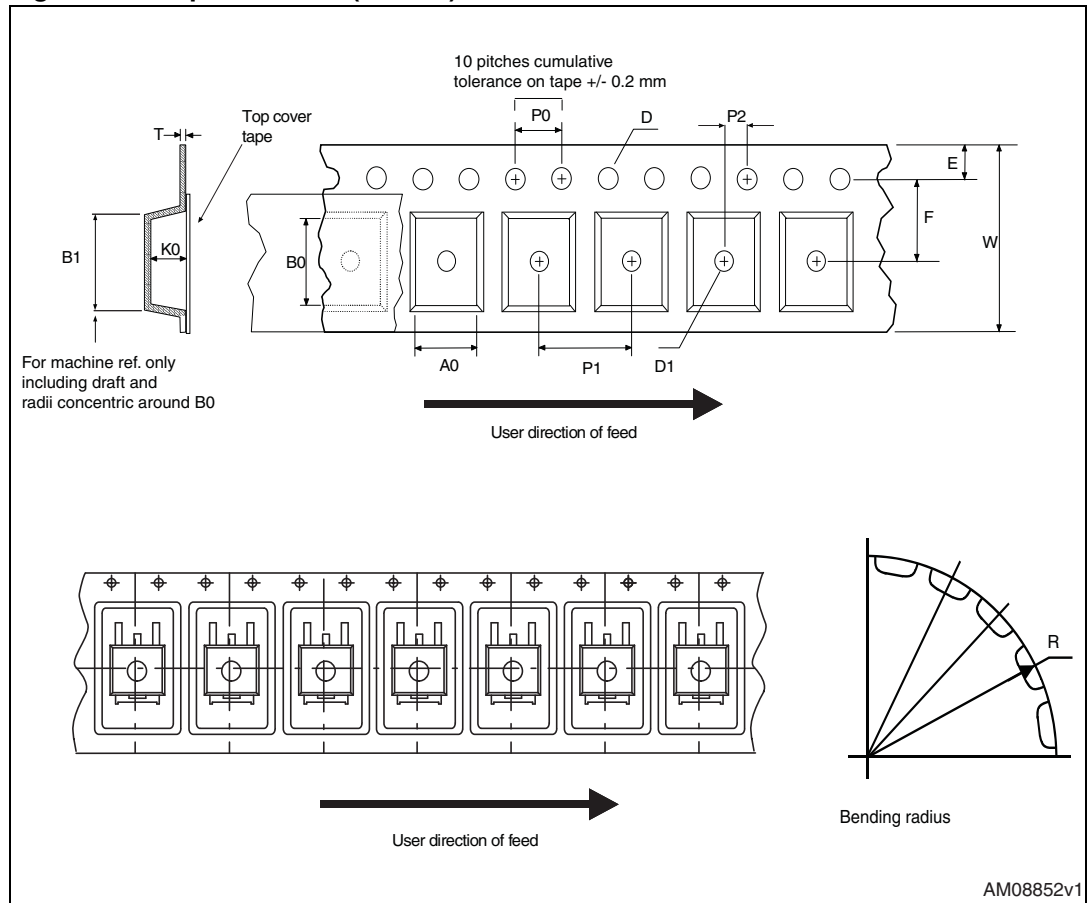
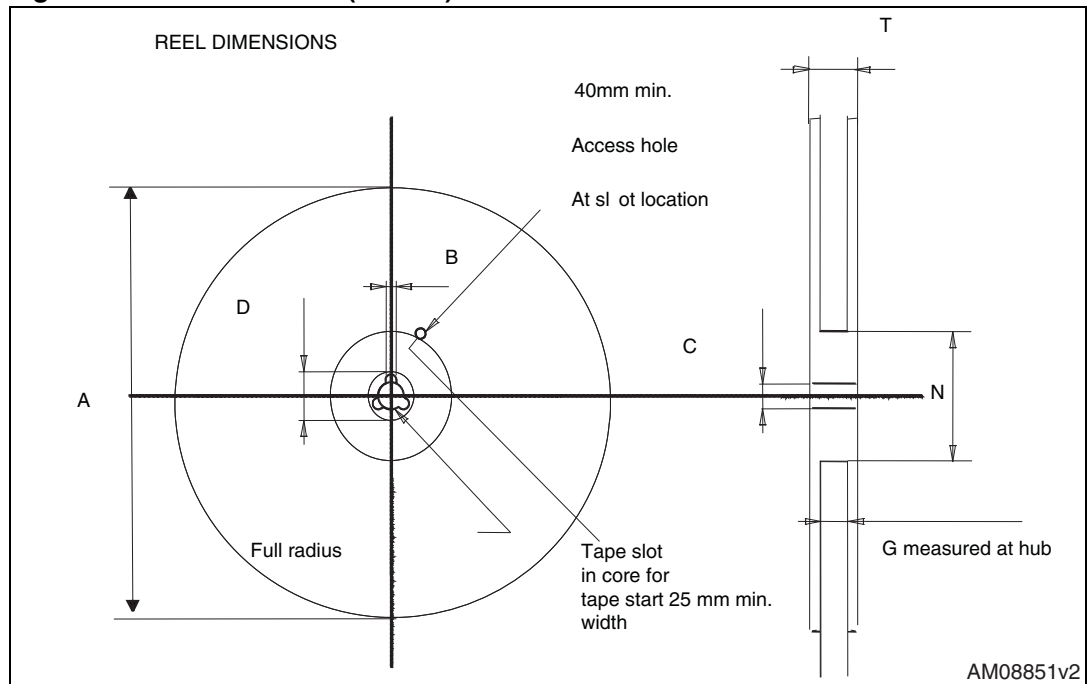

Figure 30. Reel for DPAK (TO-252)



6 Revision history

Table 14. Document revision history

Date	Revision	Changes
09-Mar-2004	1	First release
23-Mar-2004	2	Modified title
02-Apr-2005	3	Added new section: <i>Electrical characteristics (curves)</i>
06-Mar-2006	4	Inserted DPAK. The document has been reformatted
25-May-2012	5	Corrected unit in <i>Table 5: On/off states</i>

Please Read Carefully:

Information in this document is provided solely in connection with ST products. STMicroelectronics NV and its subsidiaries ("ST") reserve the right to make changes, corrections, modifications or improvements, to this document, and the products and services described herein at any time, without notice.

All ST products are sold pursuant to ST's terms and conditions of sale.

Purchasers are solely responsible for the choice, selection and use of the ST products and services described herein, and ST assumes no liability whatsoever relating to the choice, selection or use of the ST products and services described herein.

No license, express or implied, by estoppel or otherwise, to any intellectual property rights is granted under this document. If any part of this document refers to any third party products or services it shall not be deemed a license grant by ST for the use of such third party products or services, or any intellectual property contained therein or considered as a warranty covering the use in any manner whatsoever of such third party products or services or any intellectual property contained therein.

UNLESS OTHERWISE SET FORTH IN ST'S TERMS AND CONDITIONS OF SALE ST DISCLAIMS ANY EXPRESS OR IMPLIED WARRANTY WITH RESPECT TO THE USE AND/OR SALE OF ST PRODUCTS INCLUDING WITHOUT LIMITATION IMPLIED WARRANTIES OF MERCHANTABILITY, FITNESS FOR A PARTICULAR PURPOSE (AND THEIR EQUIVALENTS UNDER THE LAWS OF ANY JURISDICTION), OR INFRINGEMENT OF ANY PATENT, COPYRIGHT OR OTHER INTELLECTUAL PROPERTY RIGHT.

UNLESS EXPRESSLY APPROVED IN WRITING BY TWO AUTHORIZED ST REPRESENTATIVES, ST PRODUCTS ARE NOT RECOMMENDED, AUTHORIZED OR WARRANTED FOR USE IN MILITARY, AIR CRAFT, SPACE, LIFE SAVING, OR LIFE SUSTAINING APPLICATIONS, NOR IN PRODUCTS OR SYSTEMS WHERE FAILURE OR MALFUNCTION MAY RESULT IN PERSONAL INJURY, DEATH, OR SEVERE PROPERTY OR ENVIRONMENTAL DAMAGE. ST PRODUCTS WHICH ARE NOT SPECIFIED AS "AUTOMOTIVE GRADE" MAY ONLY BE USED IN AUTOMOTIVE APPLICATIONS AT USER'S OWN RISK.

Resale of ST products with provisions different from the statements and/or technical features set forth in this document shall immediately void any warranty granted by ST for the ST product or service described herein and shall not create or extend in any manner whatsoever, any liability of ST.

ST and the ST logo are trademarks or registered trademarks of ST in various countries.

Information in this document supersedes and replaces all information previously supplied.

The ST logo is a registered trademark of STMicroelectronics. All other names are the property of their respective owners.

© 2012 STMicroelectronics - All rights reserved

STMicroelectronics group of companies

Australia - Belgium - Brazil - Canada - China - Czech Republic - Finland - France - Germany - Hong Kong - India - Israel - Italy - Japan - Malaysia - Malta - Morocco - Philippines - Singapore - Spain - Sweden - Switzerland - United Kingdom - United States of America

www.st.com