

Dual-Channel, 3.3V/500mA and 1.8V/300mA Linear Regulator

Features

- **Fixed Output Voltage :**
V_{OUT1}=3.3V/500mA
V_{OUT2}=1.8V/300mA
- **Low Dropout Voltage (Defined as the Minimum Input/Output Voltage difference):**
Output 1 Dropout Voltage : 0.6V (at 500mA)
Output 2 Dropout Voltage : 0.9V (at 300mA)
- **Stable with 4.7mF Output Capacitor(at V_{OUT1})**
Stable with 2.2mF Output Capacitor(at V_{OUT2})
- **Built-In Thermal Protection**
- **Built-In Current-Limit Protection**
- **Fast Transient Response**
- **Short Setting Time**
- **SOP-8 and SOP-8P Packages Available**
- **Lead Free and Green Devices Available (RoHS Compliant)**

Applications

- **Desktop Computer**
- **Networking Systems**
- **Optical Data Storage Systems**

General Description

The APL5523 is a dual low dropout regulator with output1 with 3.3V/0.5A and output2 with 1.8V/0.3A output capability. In order to obtain lower dropout voltage and faster transient response, which is critical for low voltage applications, the APL5523 has been optimized. The dropout voltages are guaranteed at 0.6V at 0.5A for output1 and 0.9V at 0.3A for output 2. Current limit is trimmed to ensure specified output current and controlled short-circuit current. On-chip thermal limiting provides protection against any combination of overload that would create excessive junction temperatures. The APL5523 regulator comes in a SOP-8 and SOP-8P packages.

Pin Configuration



SOP-8 (Top View)

SOP-8P (Top View)

= Thermal Pad (connected to the GND plane for better heat dissipation)

Ordering and Marking Information

<p>APL5523 □□□-□□□</p> <ul style="list-style-type: none"> — Assembly Material — Handling Code — Temperature Range — Package Code 	<p>Package Code K : SOP-8 KA : SOP-8P Operating Junction Temperature Range C : 0 to 150 °C Handling Code TR : Tape & Reel Assembly Material G : Halogen and Lead Free Device</p>
<p>APL5523 K/KA : APL5523 XXXXX</p>	<p>XXXXX - Date Code</p>

Note: ANPEC lead-free products contain molding compounds/die attach materials and 100% matte tin plate termination finish; which are fully compliant with RoHS. ANPEC lead-free products meet or exceed the lead-free requirements of IPC/JEDEC J-STD-020C for MSL classification at lead-free peak reflow temperature. ANPEC defines "Green" to mean lead-free (RoHS compliant) and halogen free (Br or Cl does not exceed 900ppm by weight in homogeneous material and total of Br and Cl does not exceed 1500ppm by weight).

ANPEC reserves the right to make changes to improve reliability or manufacturability without notice, and advise customers to obtain the latest version of relevant information to verify before placing orders.

Absolute Maximum Ratings

Symbol	Parameter	Rating	Unit
V_{IN}, V_{OUT}	Input Voltage or Out Voltage	6	V
$R_{TH,JA}$	Thermal Resistance – Junction to Ambient		
	SOP-8	150	°C/W
	SOP-8-P	75	
$R_{TH,JC}$	Thermal Resistance – Junction to Case		
	SOP-8	30	°C/W
	SOP-8-P	5	
P_D	Power Dissipation	Internally Limited	W
T_J	Operating Junction Temperature		
	Control Section	0 to 125	°C
	Power Transistor	0 to 150	
T_{STG}	Storage Temperature Range	-65 to +150	°C
T_L	Maximum Lead Soldering Temperature, 10 Seconds	260	°C

Electrical Characteristics

Unless otherwise noted these specifications apply over full temperature, $C_{IN}=1\mu F$, $C_{OUT1}=4.7\mu F$, $C_{OUT2}=2.2\mu F$, $T_J=0$ to $125^\circ C$. Typical values refer to $T_J=25^\circ C$.

Symbol	Parameter	Test Conditions	APL5523			Unit
			Min.	Typ.	Max.	
V_{IN}	Input Voltage		2.7	-	6	V
ISHORT	Short Current	$V_{OUT}=0V$	-	50	-	mA
OTS	Over-Temperature Shutdown		-	150	-	°C
	Over-Temperature Shutdown Hysteresis	Hysteresis	-	20	-	°C
TC	Output-Voltage Temperature Coefficient		-	100	-	ppm/°C
I_Q	Quiescent Current	$I_{OUT1}=500mA, I_{OUT2}=300mA$	-	900	1000	μA
		$I_{OUT1}=0mA, I_{OUT2}=0mA$	-	100	200	
Output1 (500mA)						
V_{OUT}	Output Voltage	$V_{IN}=5V$	$V_{OUT}-2\%$	3.3	$V_{OUT}+2\%$	V
I_{LIMIT}	Circuit Current Limit	$V_{IN}=V_{OUT}+1V$	-	900	-	mA
I_{OUT}	Load Current	$V_{IN}=V_{OUT}+1V$	500	-	-	mA
REG _{LINE}	Line Regulation	$V_{OUT}+1V < V_{CC} < 6.0V, I_{OUT}=1mA$	-	5	10	mV
REG _{LOAD}	Load Regulation	$V_{IN}=V_{OUT}+1V, 0mA < I_{OUT} < I_{MAX}$	-	40	60	mV
PSRR	Ripple Rejection	$F \leq 1kHz, 1V_{pp}$ at $I_{OUT}=50mA$	40	48	-	dB
V_{DROP}	Dropout Voltage ^(Note1)	$I_{OUT}=500mA$	-	0.6	0.7	V
C_{OUT}	Output Capacitor		-	4.7	-	μF
	ESR		0.01	0.1	1	Ohm

Electrical Characteristics (Cont.)

Unless otherwise noted these specifications apply over full temperature, $C_{IN}=1\mu F$, $C_{OUT1}=4.7\mu F$, $C_{OUT2}=2.2\mu F$, $T_J=0$ to $125^\circ C$. Typical values refer to $T_J=25^\circ C$.

Symbol	Parameter	Test Conditions	APL5523			Unit
			Min.	Typ.	Max.	
Output2 (300mA)						
V_{OUT}	Output Voltage	$V_{IN}=5V$	$V_{OUT}-2\%$	1.8	$V_{OUT}+2\%$	V
I_{LIMIT}	Circuit Current Limit	$V_{IN}=V_{OUT}+1V$	-	900	-	mA
I_{OUT}	Load Current	$V_{IN}=V_{OUT}+1V$	300	-	-	mA
REG_{LINE}	Line Regulation	$V_{OUT}+1V < V_{CC} < 6.0V$, $I_{OUT}=1mA$	-	4	10	mV
REG_{LOAD}	Load Regulation	$V_{IN}=V_{OUT}+1V$, $0mA < I_{OUT} < I_{MAX}$	-	20	40	mV
PSRR	Ripple Rejection	$F \leq 1kHz$, $1V_{pp}$ at $I_{OUT}=50mA$	45	55	-	dB
V_{DROP}	Dropout Voltage ^(Note1)	$I_{OUT}=300mA$	-	0.9	1	V
C_{OUT}	Output Capacitor		-	2.2	-	μF
	ESR		0.01	0.1	1	Ohm

Note 1: Dropout voltage definition : $V_{IN}-V_{OUT}$ when V_{OUT} is 2% below the value of V_{OUT} for $V_{IN} = V_{OUT}+1V$.

Pin Description

PIN		I/O	FUNCTION
NO.	NAME		
1	VOUT1	O	VOUT1 output Voltage 3.3V. Sources up to 500mA.
2	VIN	I	Supply Voltage.
3	VIN	I	Supply Voltage.
4	VOUT2	O	VOUT2 output Voltage 1.8V. Sources up to 300mA.
5	GND		Ground also functions as a heatsink. Solder to the ground plane to maximize thermal dissipation
6	GND		
7	GND		
8	GND		

Block Diagram

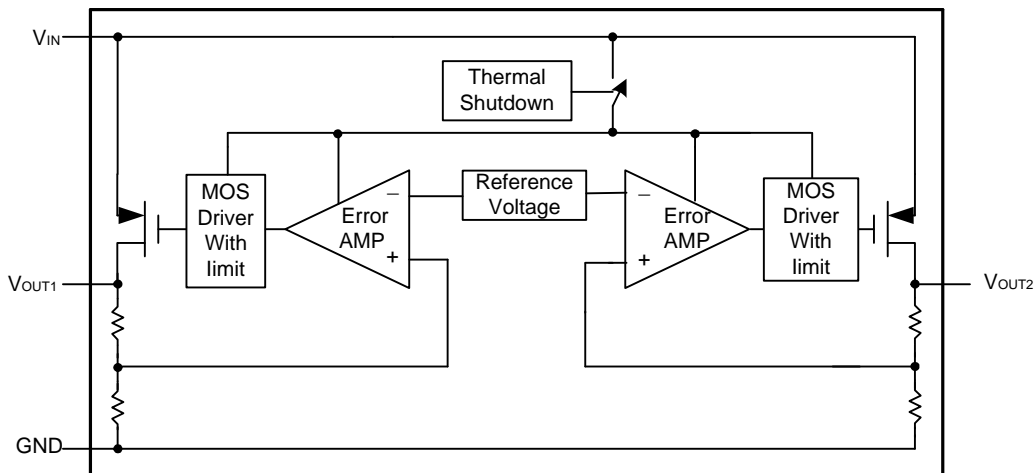

Typical Application Circuit

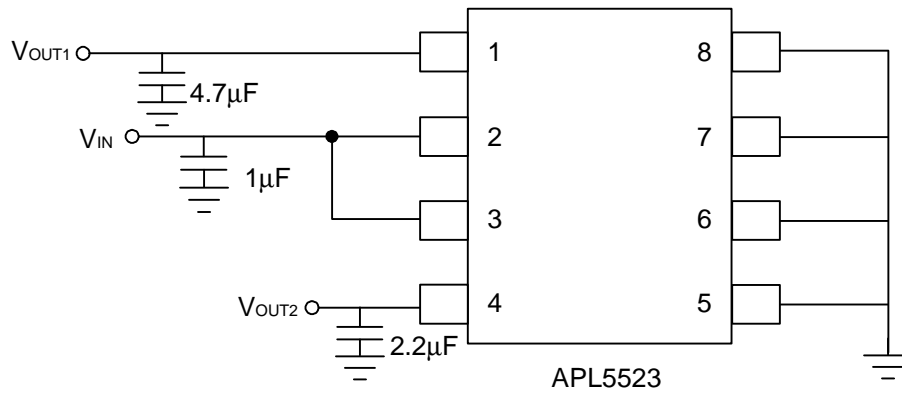

Typical Operating Characteristics

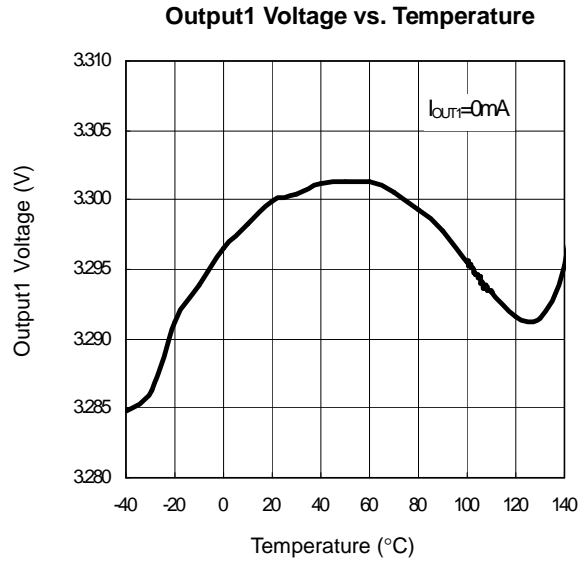
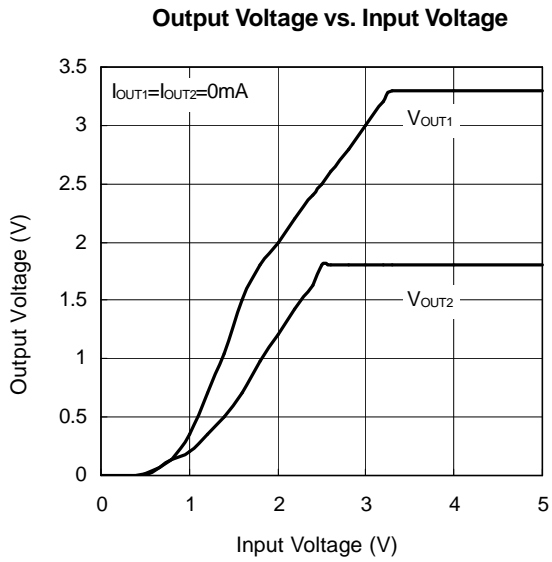
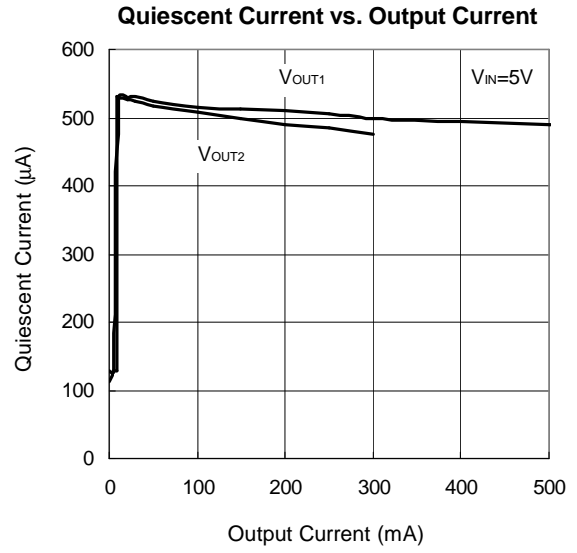
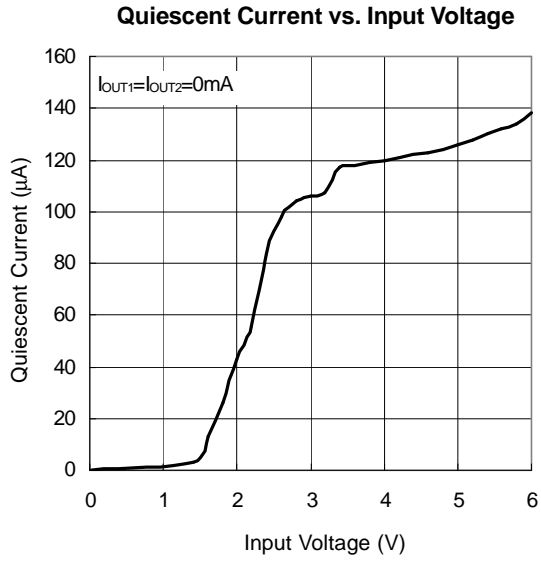

Typical Operating Characteristics (Cont.)

Output2 Voltage vs. Temperature

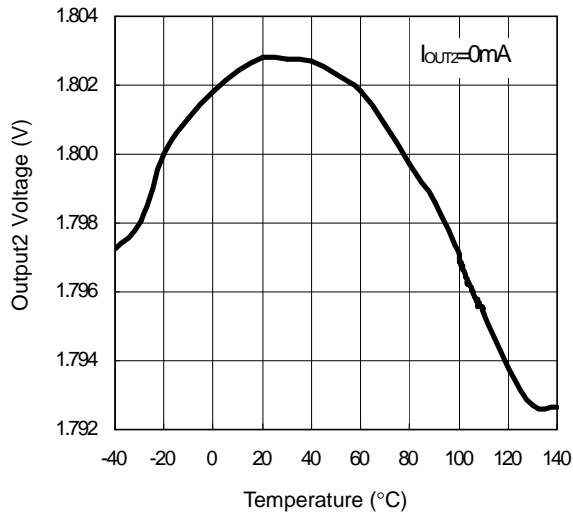

Dropout Voltage vs. Output Current

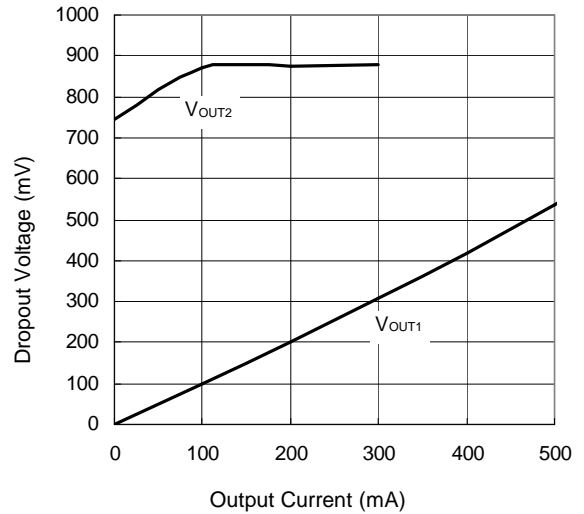

PSRR vs. Frequency

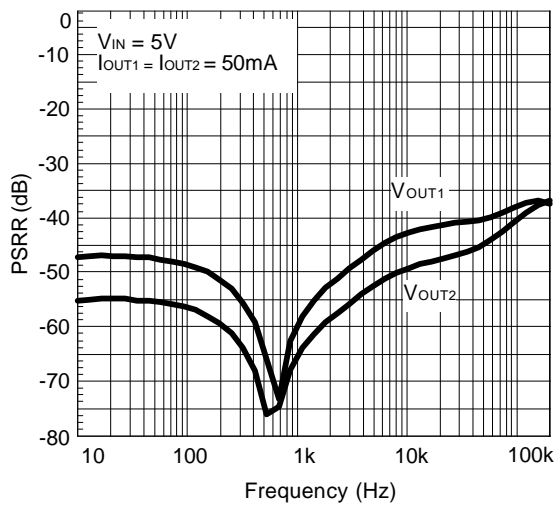

Load-Transient Response

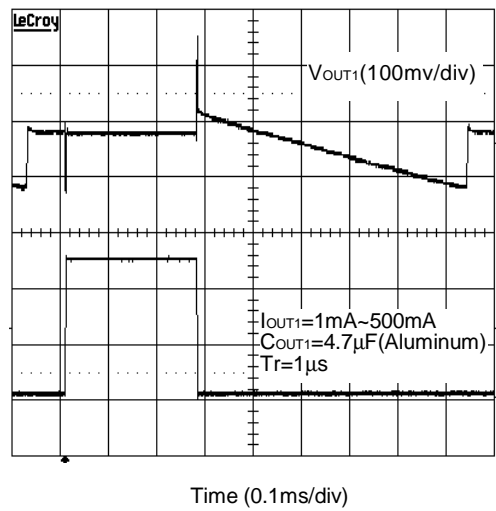

Typical Operating Characteristics (Cont.)

Load-Transient Response

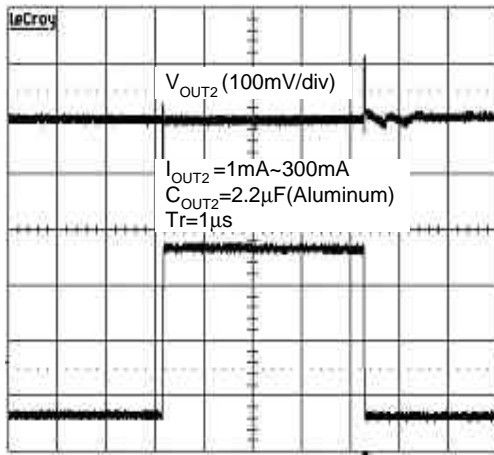

Time(0.1ms/div)

Line-Transient Response

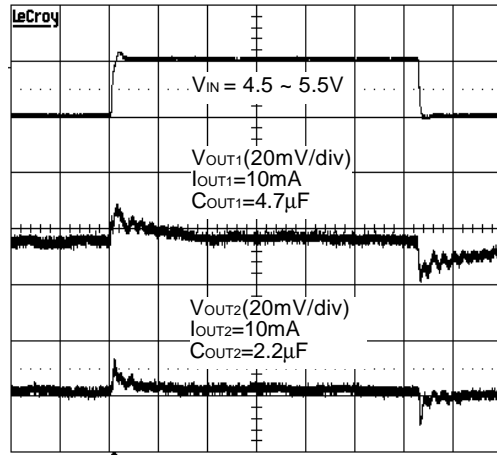

Time(20µs/div)

Output Current vs. VIN

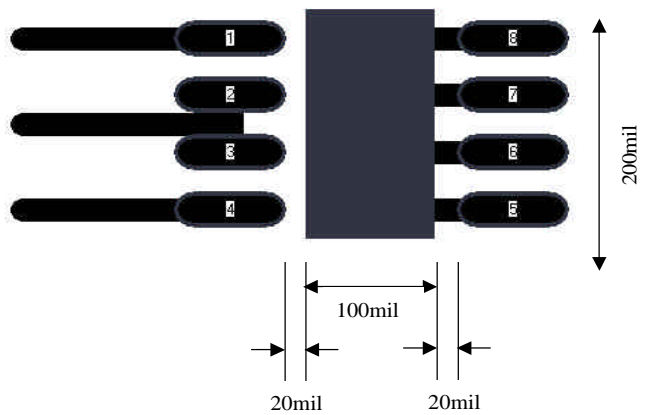
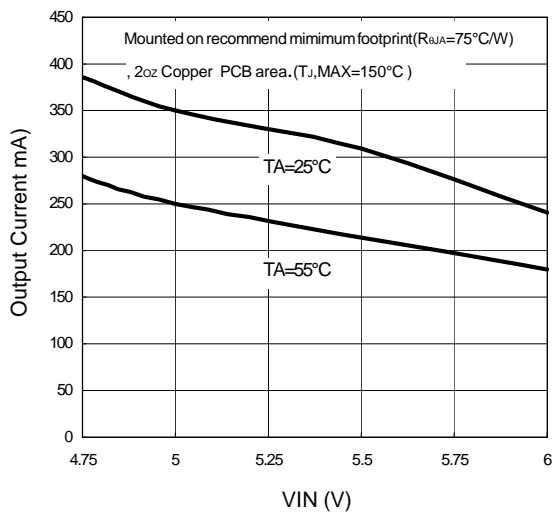

Package Information

SOP-8P

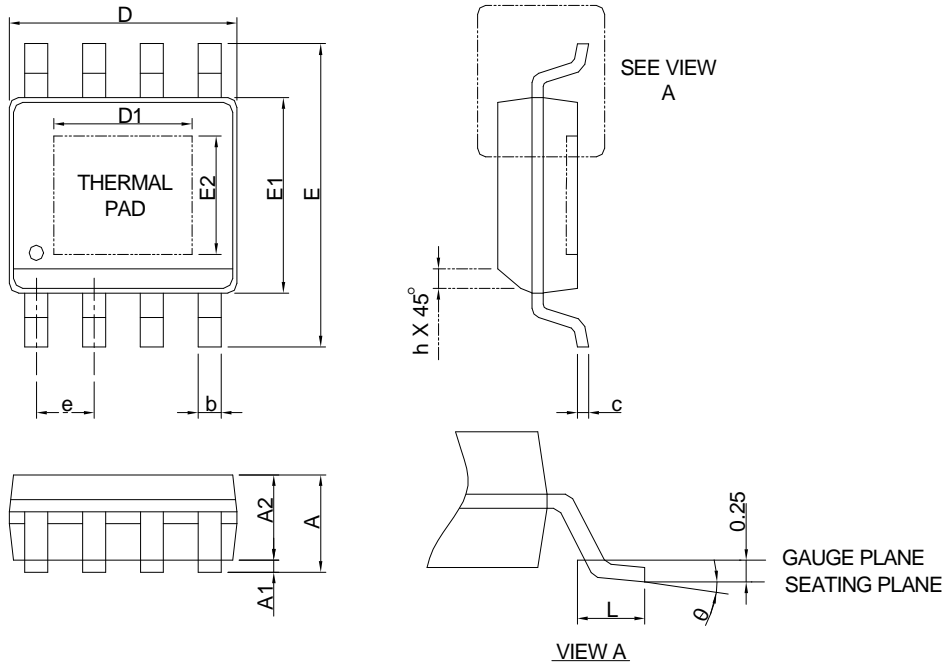

SYMBOL	SOP-8P			
	MILLIMETERS		INCHES	
	MIN.	MAX.	MIN.	MAX.
A		1.60		0.063
A1	0.00	0.15	0.000	0.006
A2	1.25		0.049	
b	0.31	0.51	0.012	0.020
c	0.17	0.25	0.007	0.010
D	4.80	5.00	0.189	0.197
D1	2.25	3.50	0.098	0.138
E	5.80	6.20	0.228	0.244
E1	3.80	4.00	0.150	0.157
E2	2.00	3.00	0.079	0.118
e	1.27 BSC		0.050 BSC	
h	0.25	0.50	0.010	0.020
L	0.40	1.27	0.016	0.050
θ	0°	8°	0°	8°

- Note : 1. Follow JEDEC MS-012 BA.
 2. Dimension "D" does not include mold flash, protrusions or gate burrs. Mold flash, protrusion or gate burrs shall not exceed 6 mil per side .
 3. Dimension "E" does not include inter-lead flash or protrusions. Inter-lead flash and protrusions shall not exceed 10 mil per side.

Package Information

SOP-8

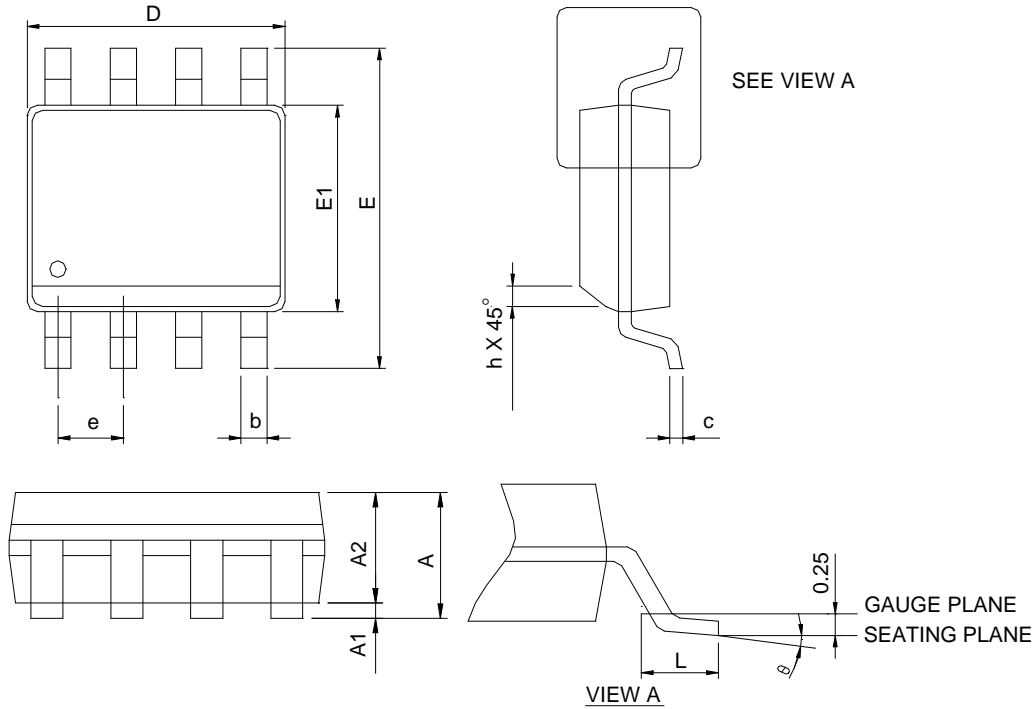

SYMBOL	SOP-8			
	MILLIMETERS		INCHES	
	MIN.	MAX.	MIN.	MAX.
A		1.75		0.069
A1	0.10	0.25	0.004	0.010
A2	1.25		0.049	
b	0.31	0.51	0.012	0.020
c	0.17	0.25	0.007	0.010
D	4.80	5.00	0.189	0.197
E	5.80	6.20	0.228	0.244
E1	3.80	4.00	0.150	0.157
e	1.27 BSC		0.050 BSC	
h	0.25	0.50	0.010	0.020
L	0.40	1.27	0.016	0.050
θ	0°	8°	0°	8°

- Note: 1. Follow JEDEC MS-012 AA.
 2. Dimension "D" does not include mold flash, protrusions or gate burrs. Mold flash, protrusion or gate burrs shall not exceed 6 mil per side.
 3. Dimension "E" does not include inter-lead flash or protrusions. Inter-lead flash and protrusions shall not exceed 10 mil per side.

Carrier Tape & Reel Dimensions

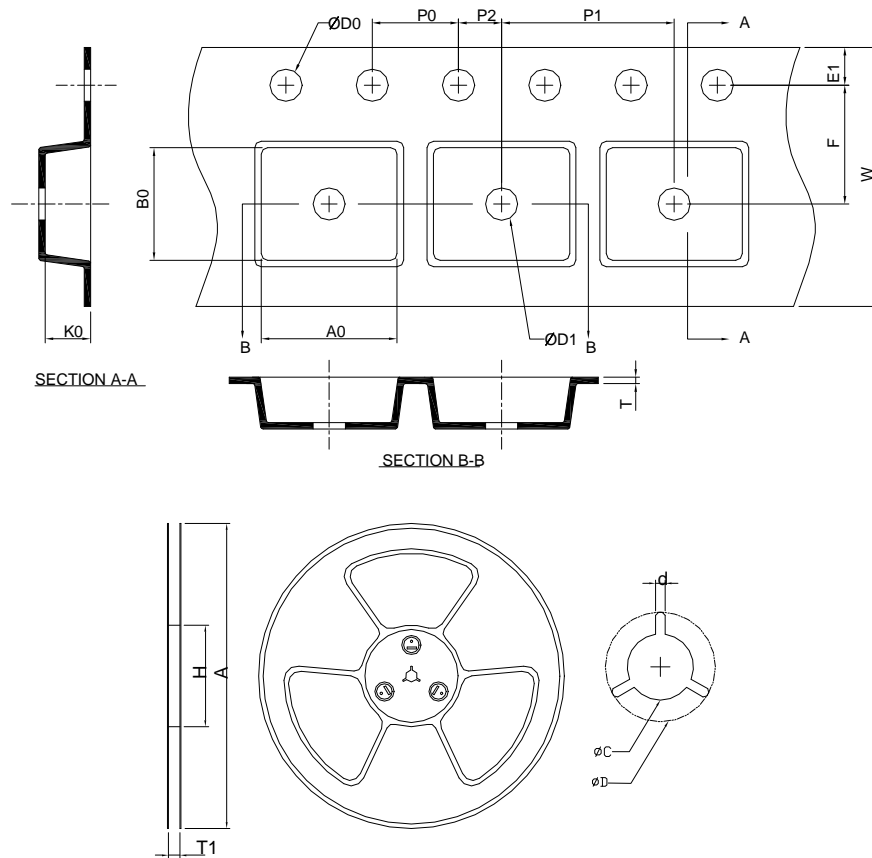

Application	A	H	T1	C	d	D	W	E1	F
SOP-8(P)	330.0 ±2.00	50 MIN.	12.4+2.00 -0.00	13.0+0.50 -0.20	1.5 MIN.	20.2 MIN.	12.0 ±0.30	1.75 ±0.10	5.5 ±0.05
	P0	P1	P2	D0	D1	T	A0	B0	K0
	4.0 ±0.10	8.0 ±0.10	2.0 ±0.05	1.5+0.10 -0.00	1.5 MIN.	0.6+0.00 -0.40	6.40 ±0.20	5.20 ±0.20	2.10 ±0.20

(mm)

Devices Per Unit

Package Type	Unit	Quantity
SOP-8(P)	Tape & Reel	2500

Taping Direction Information

SOP-8(P)

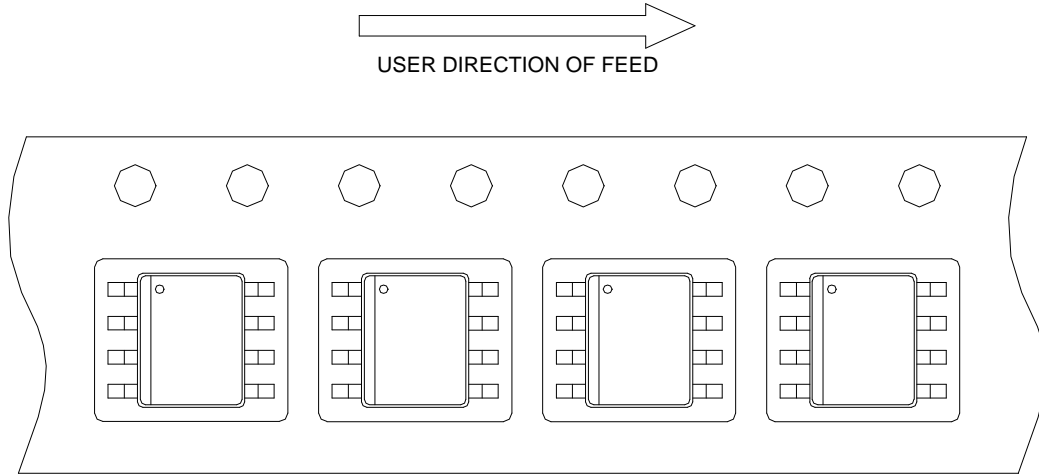

Classification Profile

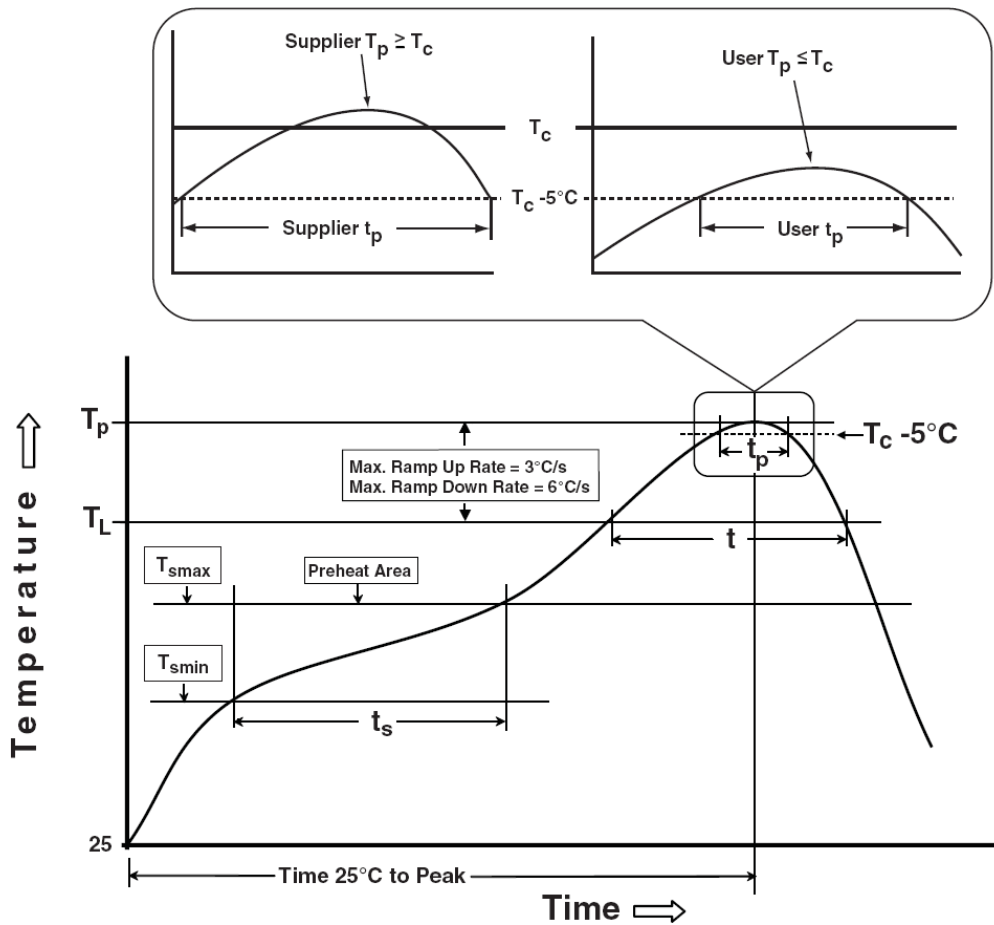

Classification Reflow Profiles

Profile Feature	Sn-Pb Eutectic Assembly	Pb-Free Assembly
Preheat & Soak		
Temperature min (T_{smin})	100 °C	150 °C
Temperature max (T_{smax})	150 °C	200 °C
Time (T_{smin} to T_{smax}) (t_s)	60-120 seconds	60-120 seconds
Average ramp-up rate (T_{smax} to T_p)	3 °C/second max.	3°C/second max.
Liquidous temperature (T_L)	183 °C	217 °C
Time at liquidous (t_L)	60-150 seconds	60-150 seconds
Peak package body Temperature (T_p)*	See Classification Temp in table 1	See Classification Temp in table 2
Time (t_p)** within 5°C of the specified classification temperature (T_c)	20** seconds	30** seconds
Average ramp-down rate (T_p to T_{smax})	6 °C/second max.	6 °C/second max.
Time 25°C to peak temperature	6 minutes max.	8 minutes max.
* Tolerance for peak profile Temperature (T_p) is defined as a supplier minimum and a user maximum.		
** Tolerance for time at peak profile temperature (t_p) is defined as a supplier minimum and a user maximum.		

Table 1. SnPb Eutectic Process – Classification Temperatures (T_c)

Package Thickness	Volume mm ³ <350	Volume mm ³ ≥350
<2.5 mm	235 °C	220 °C
≥2.5 mm	220 °C	220 °C

Table 2. Pb-free Process – Classification Temperatures (T_c)

Package Thickness	Volume mm ³ <350	Volume mm ³ 350-2000	Volume mm ³ >2000
<1.6 mm	260 °C	260 °C	260 °C
1.6 mm – 2.5 mm	260 °C	250 °C	245 °C
≥2.5 mm	250 °C	245 °C	245 °C

Reliability Test Program

Test item	Method	Description
SOLDERABILITY	JESD-22, B102	5 Sec, 245°C
HOLT	JESD-22, A108	1000 Hrs, Bias @ 125°C
PCT	JESD-22, A102	168 Hrs, 100%RH, 2atm, 121°C
TCT	JESD-22, A104	500 Cycles, -65°C~150°C
ESD	JESD-22, A114; A115	VHBM 2KV, VMM 200V
Latch-Up	JESD 78	10ms, 1 _{tr} 100mA

Customer Service

Anpec Electronics Corp.

Head Office :

No.6, Dusing 1st Road, SBIP,

Hsin-Chu, Taiwan, R.O.C.

Tel : 886-3-5642000

Fax : 886-3-5642050

Taipei Branch :

2F, No. 11, Lane 218, Sec 2 Jhongsing Rd.,

Sindian City, Taipei County 23146, Taiwan

Tel : 886-2-2910-3838

Fax : 886-2-2917-3838