

## High Voltage Green-Mode PWM Controller with Brown-Out Protection

Rev. 00

### General Description

The LD7577B integrates several functions of protections, and EMI-improved solution in SOP-8/ DIP-8 package. It minimizes the component counts and the circuit space.

The device provides functions of low startup current, green-mode power-saving operation, leading-edge blanking of the current sensing and internal slope compensation. Also, it features more protections like OLP (Over Load Protection), OVP (Over Voltage Protection), and brownout protection to prevent the circuit from being damaged under abnormal conditions.

### Features

- High-Voltage (500V) Startup Circuit
- Current Mode Control
- Non-Audible-Noise Green Mode Control
- UVLO (Under Voltage Lockout)
- LEB (Leading-Edge Blanking) on CS Pin
- Internal Slope Compensation
- OVP (Over Voltage Protection) on Vcc Pin
- OLP (Over Load Protection)
- Precision Brownout Protection
- 500mA Driving Capability

### Applications

- Switching AC/DC Adaptor and Battery Charger
- Open Frame Switching Power Supply
- LCD Monitor/TV Power

### Typical Application

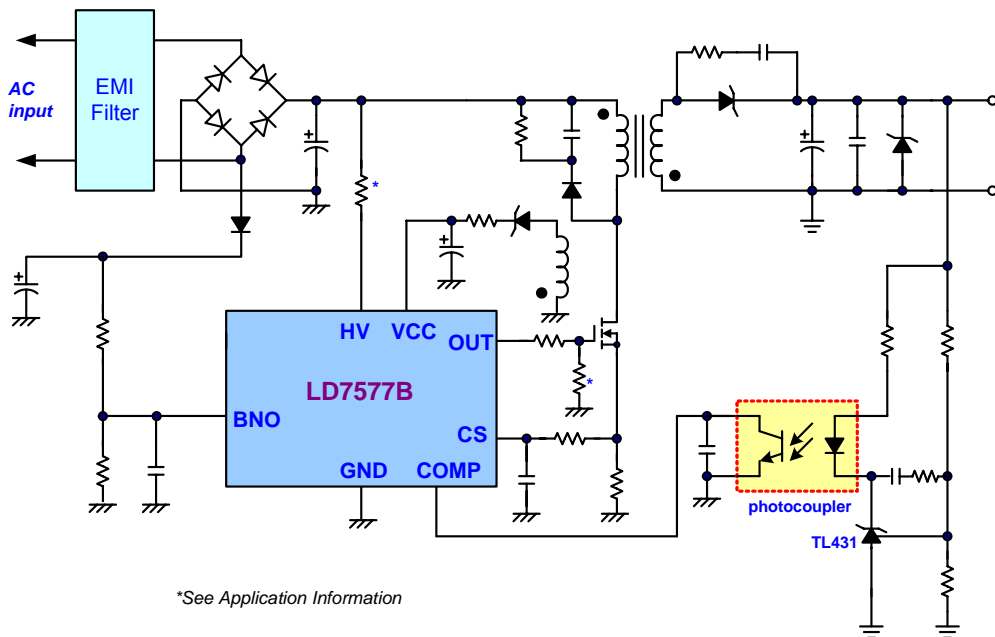

## Pin Configuration

SOP-8 & DIP-8 (TOP VIEW)

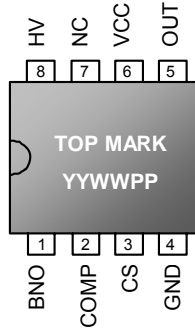

YY: Year code  
 WW: Week code  
 PP: Production code

## Ordering Information

Part number	Package	Top Mark	Shipping
LD7577B GS	SOP-8 Green package	LD7577BGS	2500 /tape & reel
LD7577B GN	DIP-8 Green package	LD7577BGN	3600 /tube /Carton

The LD7577B is ROHS compliant/ green packaged.

## Pin Descriptions

PIN	NAME	FUNCTION
1	BNO	Brownout Protection Pin. Connect a resistor divider between this pin and bulk capacitor voltage to set the brownout level. If the voltage is less than threshold voltage, the PWM output will be disabled.
2	COMP	Voltage feedback pin. By connecting a photo-coupler to close the control loop, it can achieve the regulation.
3	CS	Current sense pin. Connect it to sense the MOSFET current.
4	GND	Ground.
5	OUT	Gate drive output to drive the external MOSFET.
6	VCC	Supply voltage pin.
7	NC	Unconnected Pin.
8	HV	Connect this pin to positive terminal of bulk capacitor to provide the startup current for the controller. When VCC voltage trips UVLO(on), this HV loop will be turned off to save the power loss of the startup circuit.

**Block Diagram**

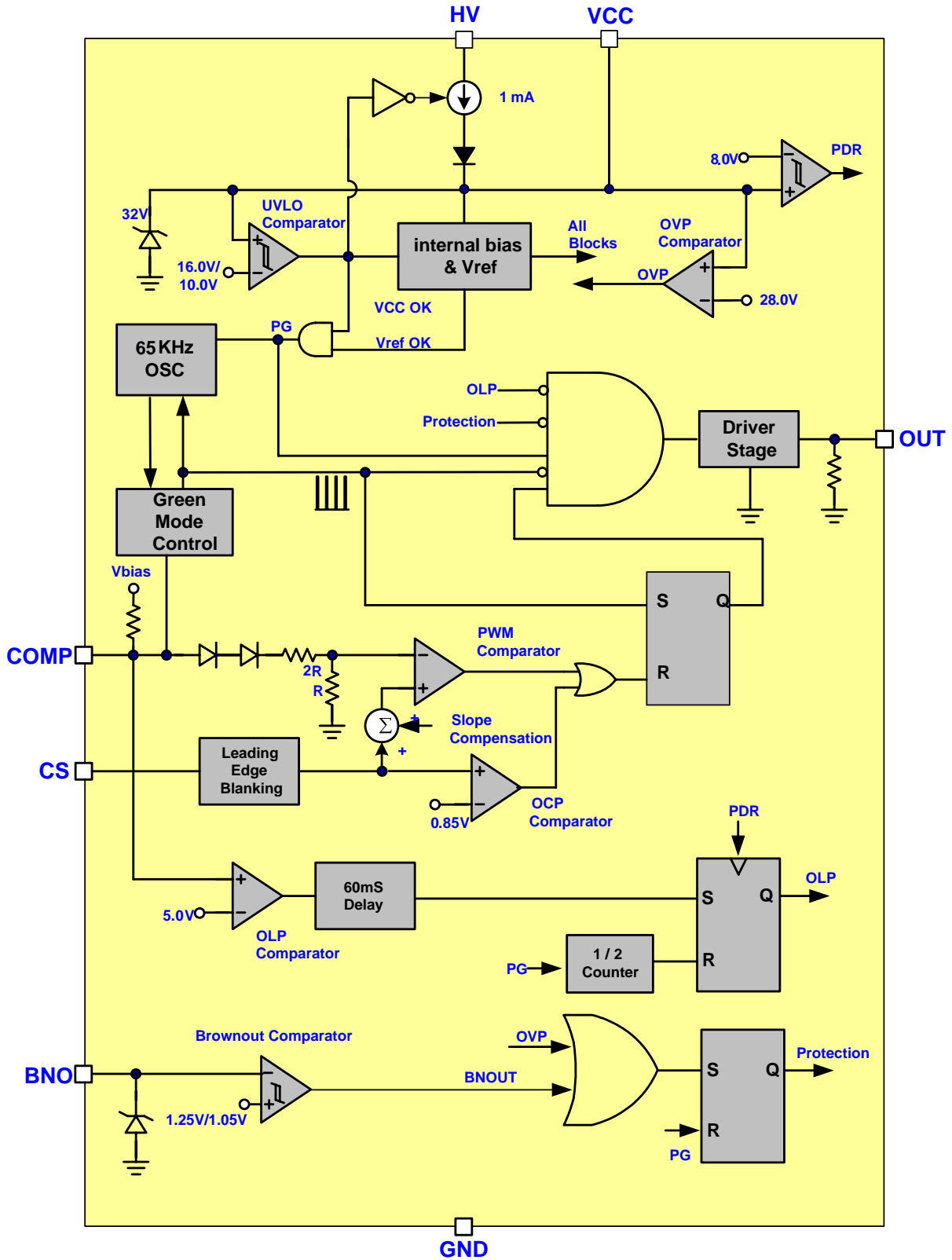

## Absolute Maximum Ratings

Supply Voltage VCC.....	30V
High-Voltage Pin, HV.....	-0.3V~500V
COMP, BNO, CS.....	-0.3 ~7V
Maximum Junction Temperature.....	150°C
Operating Ambient Temperature Range.....	-40°C to 85°C
Operating Junction Temperature Range.....	-40°C to 125°C
Storage Temperature Range.....	-65°C to 150°C
Package Thermal Resistance (SOP-8).....	160°C/W
Package Thermal Resistance (DIP-8).....	100°C/W
Power Dissipation (SOP-8, at Ambient Temperature = 85°C).....	400mW
Power Dissipation (DIP-8, at Ambient Temperature = 85°C).....	650mW
Lead temperature (Soldering, 10sec).....	260°C
ESD Voltage Protection, Human Body Model (except HV Pin).....	2.5KV
ESD Voltage Protection, Machine Model (except HV Pin).....	250V
Gate Output Current.....	500mA

### Caution:

Stresses beyond the ratings specified in "Absolute Maximum Ratings" may cause permanent damage to the device. This is a stress only rating and operation of the device at these or any other conditions above those indicated in the operational sections of this specification is not implied.

## Electrical Characteristics

(T<sub>A</sub> = +25°C unless otherwise stated, V<sub>CC</sub>=15.0V)

PARAMETER	CONDITIONS	MIN	TYP	MAX	UNITS
<b>High-Voltage Supply (HV Pin)</b>					
High-Voltage Current Source	V <sub>CC</sub> < UVLO(on), HV=500V	0.5	1.0	1.5	mA
Off-State Leakage Current	V <sub>CC</sub> > UVLO(off), HV=500V	-	8.9	35	μA
<b>Supply Voltage (V<sub>CC</sub> Pin)</b>					
Startup Current	V <sub>CC</sub> < UVLO(on)	-	320	-	μA
Operating Current (with 1nF load on OUT pin)	V <sub>COMP</sub> =0V	-	3.0	-	mA
	V <sub>COMP</sub> =3V	-	3.3	-	mA
	OLP tripped	-	0.7	-	mA
	OVP tripped	-	0.8	-	mA
UVLO (off)		9.00	10.00	11.00	V
UVLO (on)		15.00	16.00	17.00	V
OVP Level		26.50	28.00	29.50	V
<b>Voltage Feedback (Comp Pin)</b>					
Short Circuit Current	V <sub>COMP</sub> =0V	-	1.5	2.2	mA
Open Loop Voltage	COMP pin open	-	5.8	-	V
Green Mode Threshold V <sub>COMP</sub>		-	3.0	-	V
Burst Mode Threshold V <sub>COMP</sub>		-	1.6	-	V
<b>Current Sensing (CS Pin)</b>					
Maximum Input Voltage		0.80	0.85	0.90	V
Leading Edge Blanking Time	V <sub>COMP</sub> >2.05V	-	250	-	nS
	V <sub>COMP</sub> <1.8V	-	630	-	
Input impedance		1	-	-	MΩ
Delay to Output		-	100	-	nS
<b>Oscillator for Switching Frequency</b>					
Frequency		60	65	70	KHz
Green Mode Frequency		-	22	-	KHz
Temp. Stability	(-40°C ~105°C)	-	5	-	%
Voltage Stability	(V <sub>CC</sub> =11V-25V)	-	1	-	%

## Electrical Characteristics

(T<sub>A</sub> = +25°C unless otherwise stated, V<sub>CC</sub>=15.0V)

PARAMETER	CONDITIONS	MIN	TYP	MAX	UNITS
<b>Brownout Protection &amp; Line Compensation (BNO Pin)</b>					
Brownout Turn-On Trip Level		1.2	1.25	1.3	V
Brownout Turn-off Trip Level		1.0	1.05	1.1	V
Saturation Voltage	IBNO=1.5μA	-	6	-	V
Input impedance		5.1	-	-	MΩ
<b>Gate Drive Output (OUT Pin)</b>					
Output Low Level	VCC=15V, I <sub>o</sub> =20mA	-	-	1	V
Output High Level	VCC=15V, I <sub>o</sub> =20mA	9	-	-	V
Rising Time	Load Capacitance=1000pF	-	100	160	nS
Falling Time	Load Capacitance=1000pF	-	30	60	nS
<b>OLP (Over Load Protection)</b>					
OLP Trip Level		-	5.0	-	V
OLP Delay Time	FS=65KHz	-	60	-	mS

## Typical Performance Characteristics

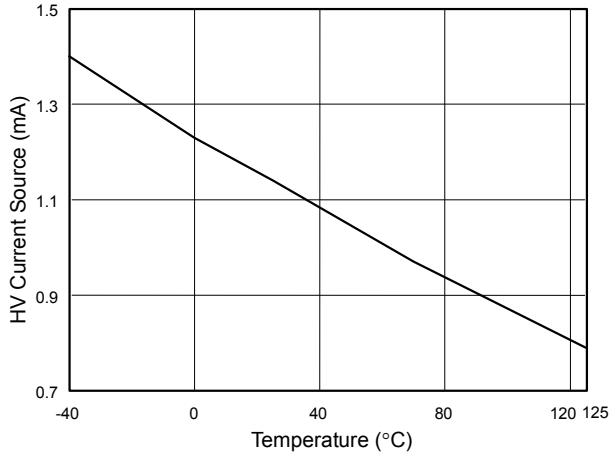

Fig. 1 HV Current Source vs. Temperature (HV=500V, Vcc=0V)

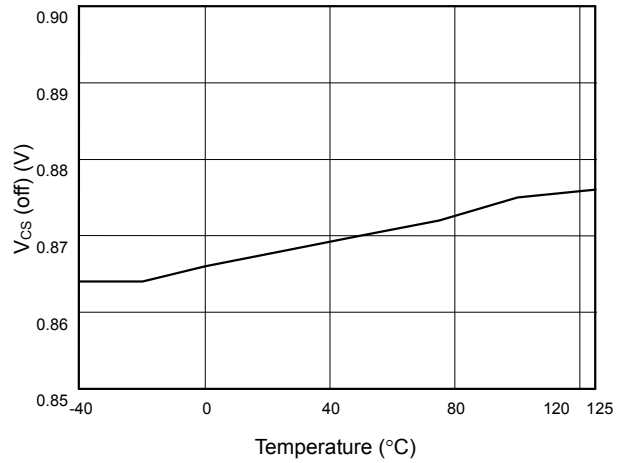

Fig. 2 Vcs (off) vs. Temperature

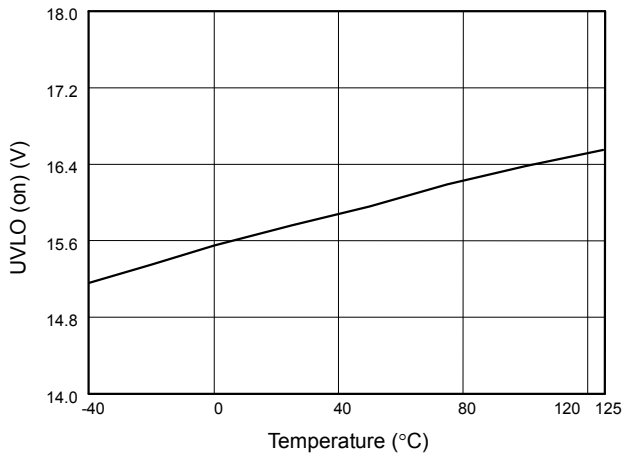

Fig. 3 UVLO (on) vs. Temperature

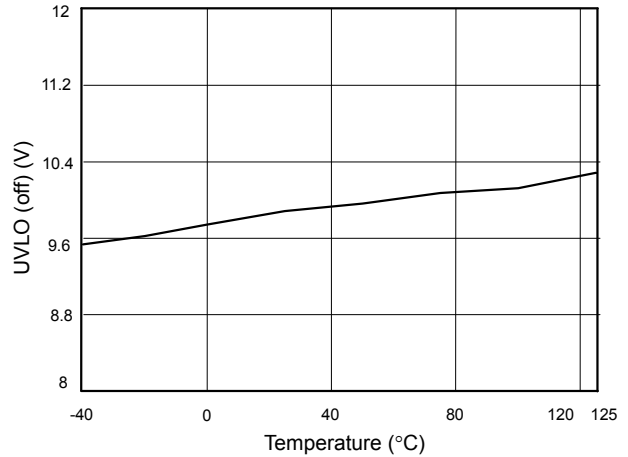

Fig. 4 UVLO (off) vs. Temperature

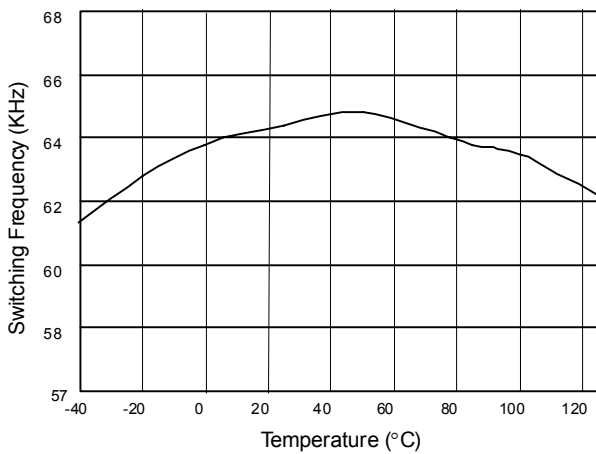

Fig. 5 TC of Switching Frequency

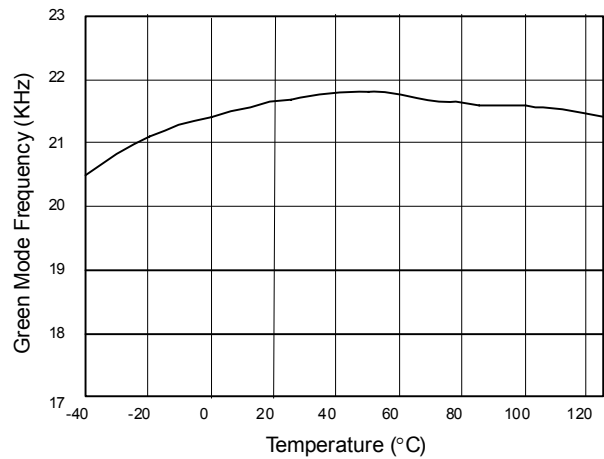

Fig. 6 TC of Green Mode frequency

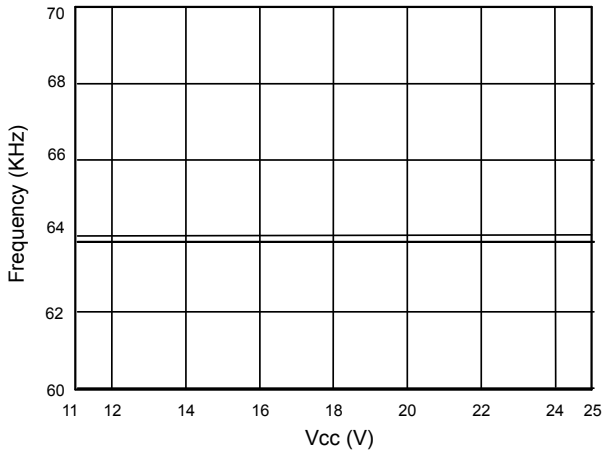

Fig. 7 Frequency vs. Vcc

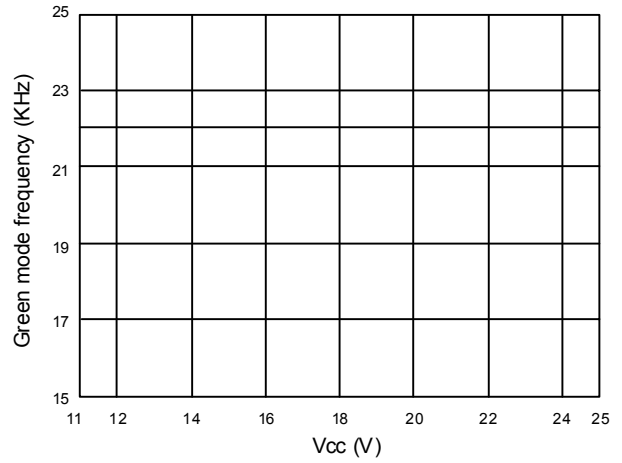

Fig. 8 Green mode frequency vs. Vcc

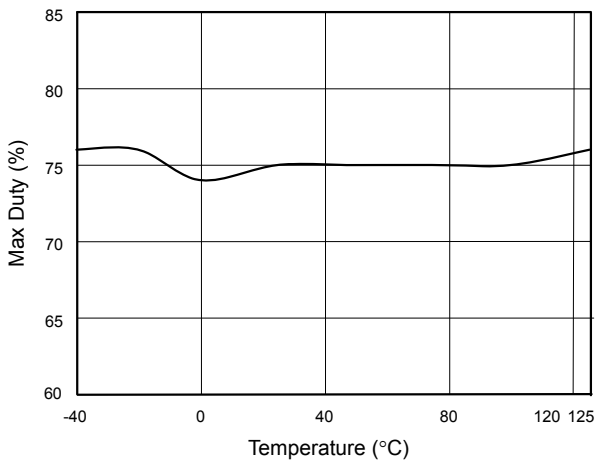

Fig. 9 Max Duty vs. Temperature

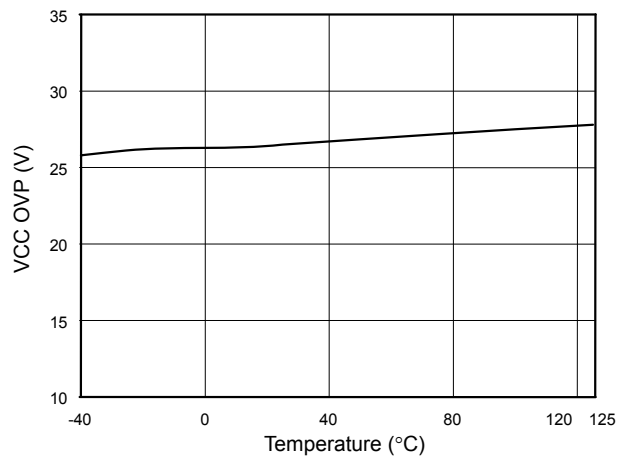

Fig. 10 VCC OVP vs. Temperature

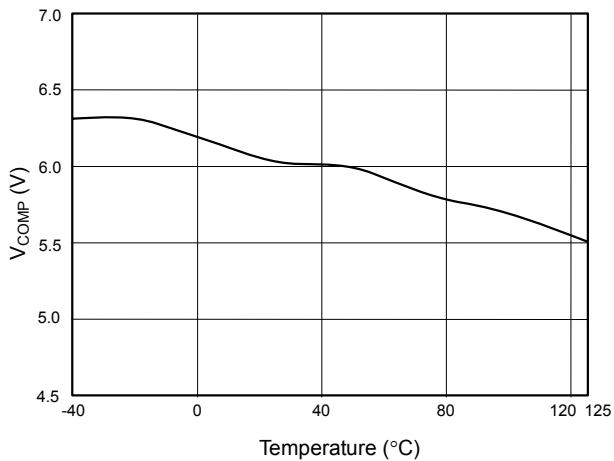

Fig. 11 V<sub>COMP</sub> open loop voltage vs. Temperature

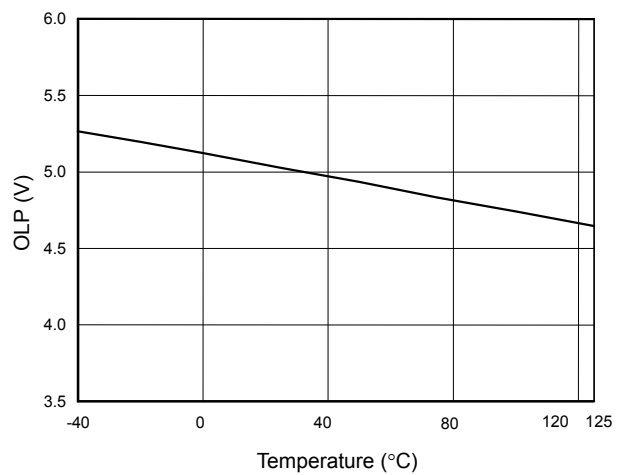

Fig. 12 OLP-Trip Level vs. Temperature



## Application Information

### Operation Overview

As long as the green power requirement becomes a trend and the power saving is becoming more and more important for switching power supplies and switching adaptors, the traditional PWM controllers are not able to support such new requirements. Furthermore, the cost and size limitation forces the PWM controllers to powerfully integrate more functions, thereby reducing the external part count. The LD7577B is ideal for these applications to provide an easy and cost effective solution; and its detailed features are described as below.

### Internal High-Voltage Startup Circuit and Under Voltage Lockout (UVLO)

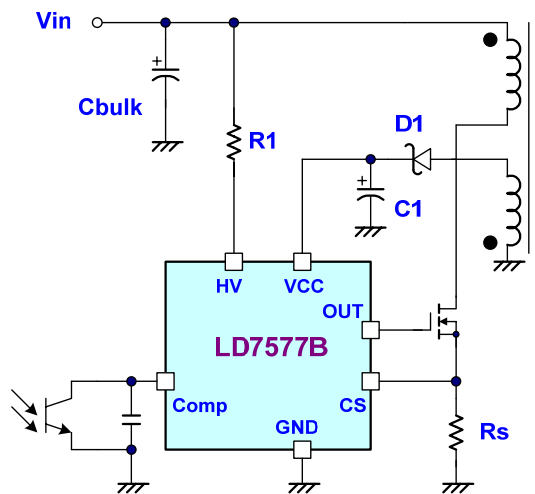

Fig. 13

Traditional circuits' power on the PWM controller through a startup resistor to constantly provide current from a rectified voltage to the capacitor connected to Vcc pin. Nevertheless, this startup resistor was usually of larger resistance, and it therefore required more power and longer time to start up.

To achieve the optimized topology, as shown in figure 13, the LD7577B is built in with high voltage startup circuit to

optimize the power saving. During the startup sequence, a high-voltage current source sinks current from  $C_{BULK}$  capacitor to provide the startup current as well as to charge the Vcc capacitor C1. During the initialization of the startup, Vcc voltage is lower than the UVLO(off) threshold thus the current source is on to supply a current of 1mA. Meanwhile, the Vcc current consumed by the LD7577B is as low as  $320\mu A$  thus most of the HV current is utilized to charge the Vcc capacitor. By using such configuration, the turn-on delay time will be almost the same no matter whether operation condition is under low-line or high-line.

When Vcc voltage reaches UVLO(on) threshold, the LD7577B is powered on to start issuing the gate drive signal, the high-voltage current source is then disabled, and the Vcc supply current will be only provided from the auxiliary winding of the transformer. Therefore, the power losses on the startup circuit beyond the startup period can be eliminated and the power saving can be easily achieved. In general application, a  $39K\Omega$  resistor is still recommended to be placed in high voltage path to limit the current if there is a negative voltage applying in any case.

An UVLO comparator is included to detect the voltage on the Vcc pin to ensure the supply voltage is high enough to power on the LD7577B PWM controller and in addition to drive the power MOSFET. As shown in Fig. 14, a Hysteresis is provided to prevent the shutdown caused by the voltage dip during startup. The turn-on and turn-off threshold levels are set at 16V and 10.0V, respectively.

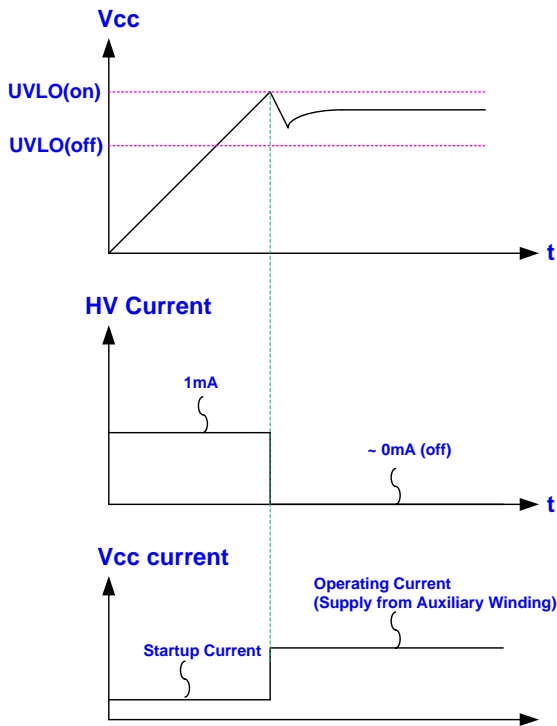

Fig. 14

## Current Sensing, Leading-edge Blanking and the Negative Spike on CS Pin

The typical current mode PWM controller feeds back both current signal and voltage signal to close the control loop and to achieve voltage regulation. LD7577B detects the primary MOSFET current from the CS pin, which is applied not only for the peak current mode control but also for the pulse-by-pulse current limit. The maximum voltage threshold of the current sensing pin is set as 0.85V. Thus the MOSFET peak current can be calculated as:

$$I_{PEAK(MAX)} = \frac{0.85V}{R_S}$$

A 250nS leading-edge blanking (LEB) time is incorporated in the input of CS pin to prevent the false-trigger caused by any current spike. For low power applications, if the total pulse width of each turn-on spike is less than 250nS and the negative spike on the CS pin is not as low as -0.3V, the R-C filter (as shown in Fig.15) can be eliminated. Nevertheless, it is strongly recommended to remain a small R-C filter (as shown in Fig. 16) for higher

power applications to avoid the CS pin being damaged by negative turn-on spikes.

## Output Stage and Maximum Duty-Cycle

An output stage of a CMOS buffer, with typical 500mA driving capability, is incorporated to drive a power MOSFET directly. And the maximum duty-cycle of the LD7577B is limited to 75% in order to avoid the transformer flux saturation.

## Voltage Feedback Loop

The voltage feedback signal is issued from the TL431 in the secondary side through the photo-coupler to COMP pin of the LD7577B. The input stage of the LD7577B, like the UC384X, is incorporated with 2 diodes voltage offset circuit and a voltage divider with 1/3 ratio. Therefore,

$$V_{+(PWM_{COMPARATOR})} = \frac{1}{3} \times (V_{COMP} - 2V_F)$$

A pull-high resistor is embedded internally, eliminating external corresponding components on a board.

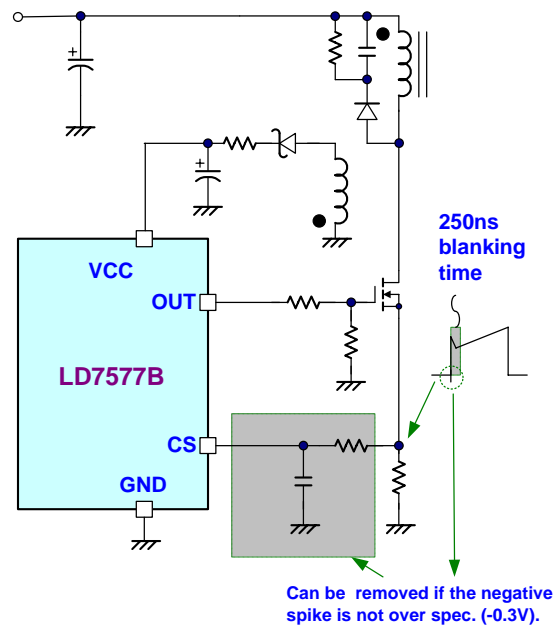

Fig. 15

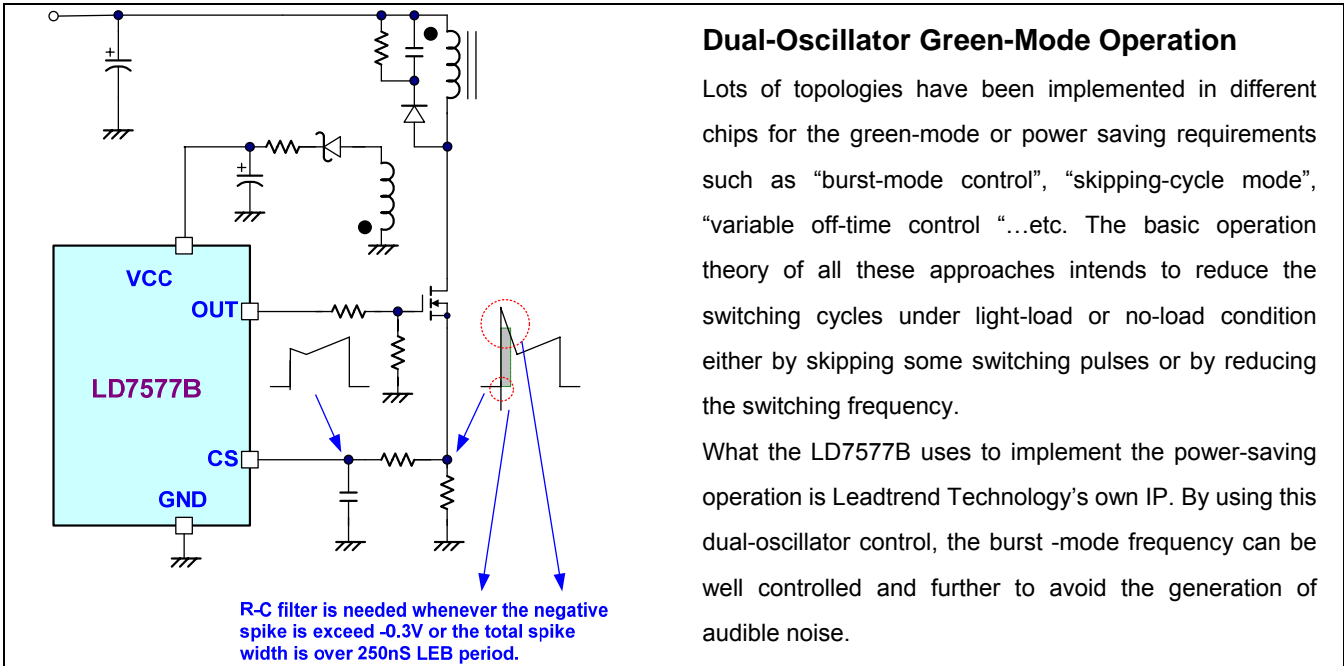

Fig. 16

### Oscillator and Switching Frequency

The switching frequency of the LD7577B is fixed as 65KHz internally to provide the optimized operations by considering the EMI performance, thermal treatment, component sizes and transformer design.

### Internal Slope Compensation

Stability is crucial for current mode control when it operates at more than 50% of duty-cycle. To stabilize the control loop, the slope compensation is required in the traditional UC384X design by injecting the ramp signal from the RT/CT pin through a coupling capacitor. In the LD7577B, the internal slope compensation circuit has been implemented to simplify the external circuit design.

### On/Off Control

Pulling COMP pin below 1.2V will turn off the LD7577B and disable the gate output pin of the LD7577B. The off-mode will be released when the pull-low signal at COMP pin is removed.

### Dual-Oscillator Green-Mode Operation

Lots of topologies have been implemented in different chips for the green-mode or power saving requirements such as “burst-mode control”, “skipping-cycle mode”, “variable off-time control “...etc. The basic operation theory of all these approaches intends to reduce the switching cycles under light-load or no-load condition either by skipping some switching pulses or by reducing the switching frequency.

What the LD7577B uses to implement the power-saving operation is Leadtrend Technology’s own IP. By using this dual-oscillator control, the burst -mode frequency can be well controlled and further to avoid the generation of audible noise.

### Over Load Protection (OLP)

To protect the circuit from being damaged under over load condition or short condition, a smart OLP function is built in with the LD7577B, as shown in Figure 17 shows the waveforms of the OLP operation. If output voltage drops, the feedback system tends to force the voltage loop toward the saturation (6.0V) and then pulls the voltage of COMP pin to high. Whenever the  $V_{COMP}$  trips to the OLP threshold 5.0V and continues over 60mS, OLP is activated and then turns off the gate output to stop the switching of power circuit. The 60mS delay time is to prevent the false trigger from the power-on and turn-off transient.

A divide-2 counter is implemented to reduce the input average power under OLP behavior. Whenever OLP is activated, the output is latched off and the divide-2 counter starts to count the number of UVLO(off). The latch is released if the 2nd UVLO(off) point is counted then the power circuit is recovered to switch again.

By using such protection mechanism, the average input power can be reduced to a very low level so that the

component temperature and stress can be controlled within the safe operating area.

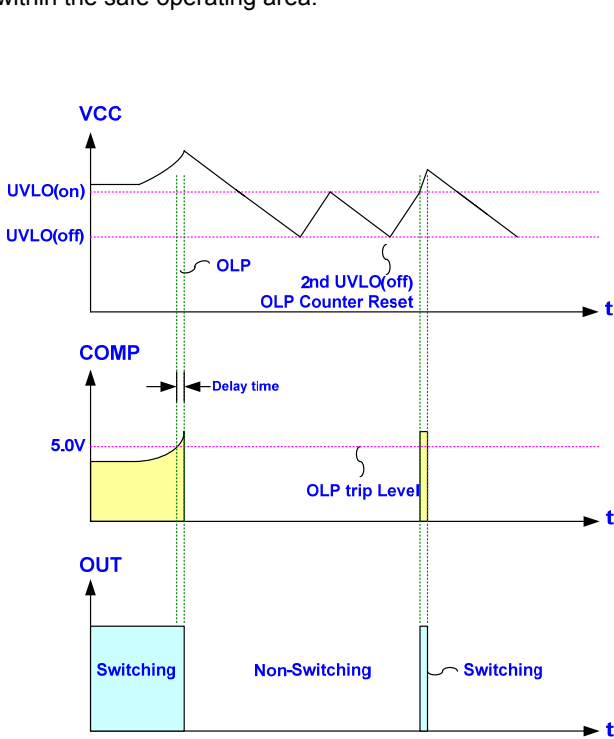

Fig. 17

### OVP (Over Voltage Protection) on Vcc

The  $V_{GS}$  ratings of the nowadays power MOSFETs are mostly with 30V maximum. To prevent the  $V_{GS}$  from fault condition, the LD7577B is implemented with over-voltage protection on Vcc. As long as the Vcc voltage is higher than OVP threshold voltage, the output gate drive circuit will be shut down, thus to stop the switching of the power MOSFET until the next  $UVLO(ON)$ .

The Vcc OVP function in the LD7577B is an auto-recovery type protection. If the OVP condition, usually caused by the feedback loop opened, is not released, the Vcc will trip to the OVP level again, re-shutting down the output. The Vcc waveform in Fig. 18 shows this auto-recovery type protection, presenting a hiccup mode.

On the other hand, the removal of the OVP condition should render the Vcc level back to normal level, causing the output automatically returning to the normal operation.

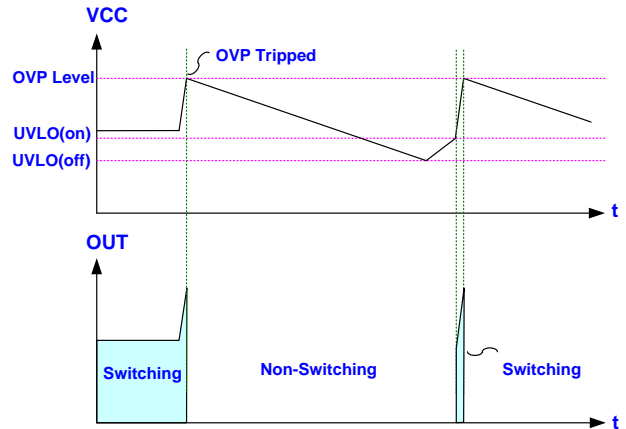

Fig. 18

### Brownout Protection

The LD7577B is programmable to set the brownout protection point and the line voltage OVP point though BNO pin.

The voltage across the BNO pin is proportional to the bulk capacitor voltage, referred as the line voltage. A brownout comparator is implemented to detect the abnormal line condition. As soon as the condition is detected, it will shut down the controller to prevent the damage. Figure 19 shows the operation. When  $V_{BNO}$  falls below 1.05V, the gate output will be kept off even Vcc has already achieved  $UVLO(ON)$ . It therefore makes Vcc hiccup between  $UVLO(ON)$  and  $UVLO(OFF)$ . Unless the line voltage is large enough to pull  $V_{BNO}$  larger than 1.23V, the gate output will not start switching even when the next  $UVLO(ON)$  is tripped. A hysteresis is implemented to prevent the false trigger during turn-on and turn-off.

In order to protect BNO pin from being damaged during the dividing resistors floating, an internal zener diode is implemented in BNO pin. Fig. 19 shows the sinking capability of the zener diode. To protect BNO pin, the current flowing in BNO pin must be below 1.5 $\mu$ A, as shown in Fig. 19.

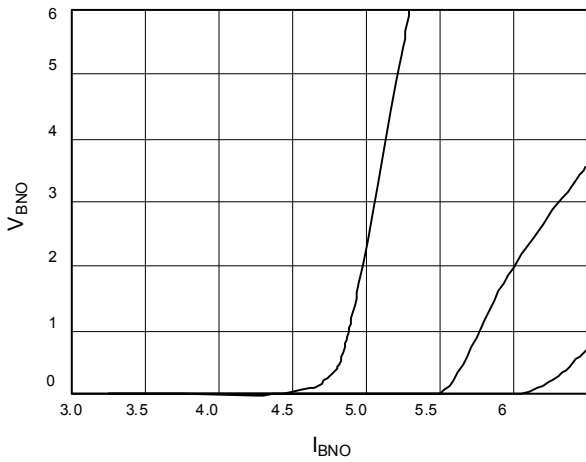

Fig. 19  $V_{BNO}$  vs.  $I_{BNO}$

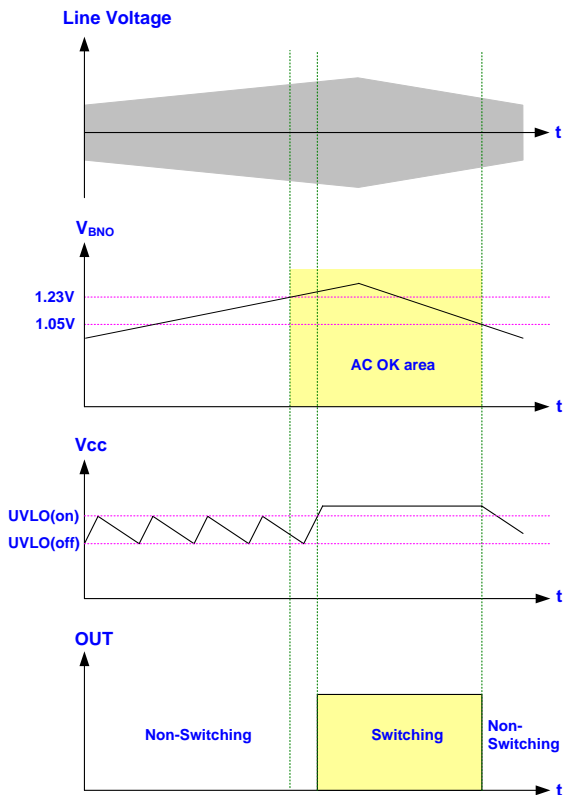

Fig. 20

## Pull-Low Resistor on the Gate Pin of MOSFET

An anti-floating resistor is implemented in the OUT pin to prevent any uncertain output, which may cause MOSFET working abnormally or false triggering-on. However, such design won't cover the conditions of disconnection of

gate resistor  $R_G$ . It is still strongly recommended to have a resistor connected at the MOSFET gate terminal (as shown in figure 21) to provide extra protection for fault conditions.

This external pull-low resistor is to prevent the MOSFET from being damaged during power-on when the gate resistor is disconnected. In such a single-fault condition, as shown in figure 22, the resistor R8 can provide a discharge path to avoid the MOSFET from being false-triggered by the coupling through the gate-to-drain capacitor  $C_{GD}$ . Therefore, the gate of MOSFET should be pulled low to maintain MOSFET in a off-state no matter the gate resistor is disconnected or opened in any case.

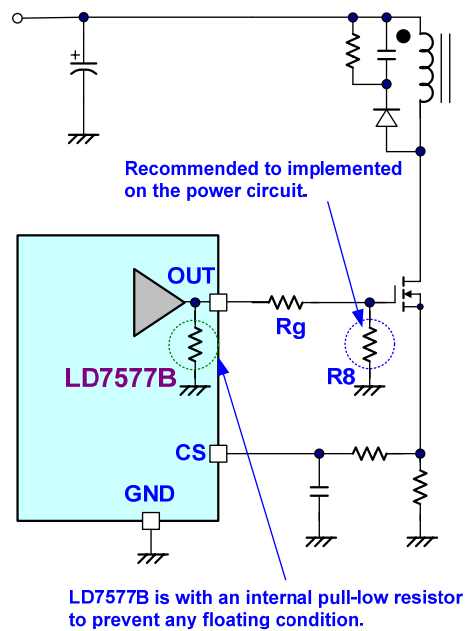

Fig. 21

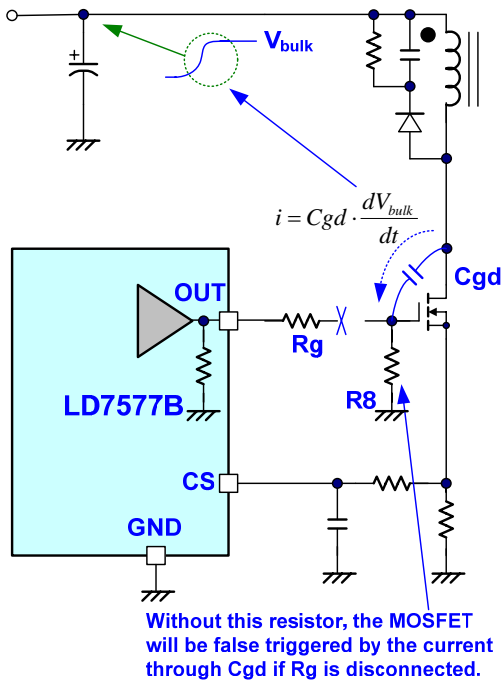

Fig. 22

### Protection Resistor on the Hi-V Path

In some other Hi-V processes and designs, there is probably some parasitic SCR caused around HV pin, V<sub>CC</sub> and GND. As shown in figure 23, a small negative spike in the HV pin may trigger this parasitic SCR and cause the latchup between V<sub>CC</sub> and GND. Such latchup will damage the chip easily because of the equivalent short-circuit induced.

The LD7577B has eliminated the parasitic SCR efficiently. Figure 24 shows the equivalent circuit of the LD7577B's Hi-V structure. It tells the LD7577B is capable to sustain negative voltage and superior than similar products. Even though, a 40KΩ resistor is still recommended to be placed on the Hi-V path

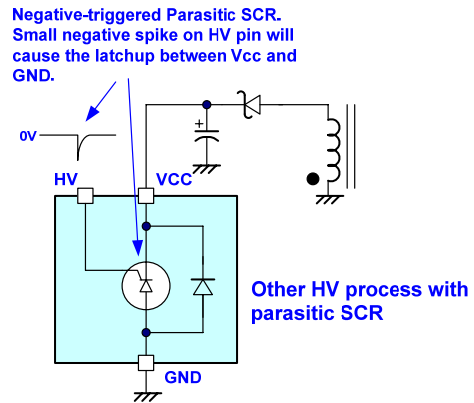

Fig. 23

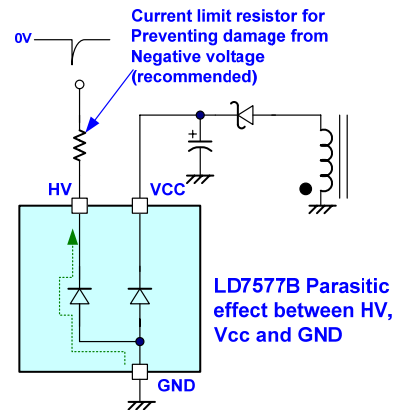
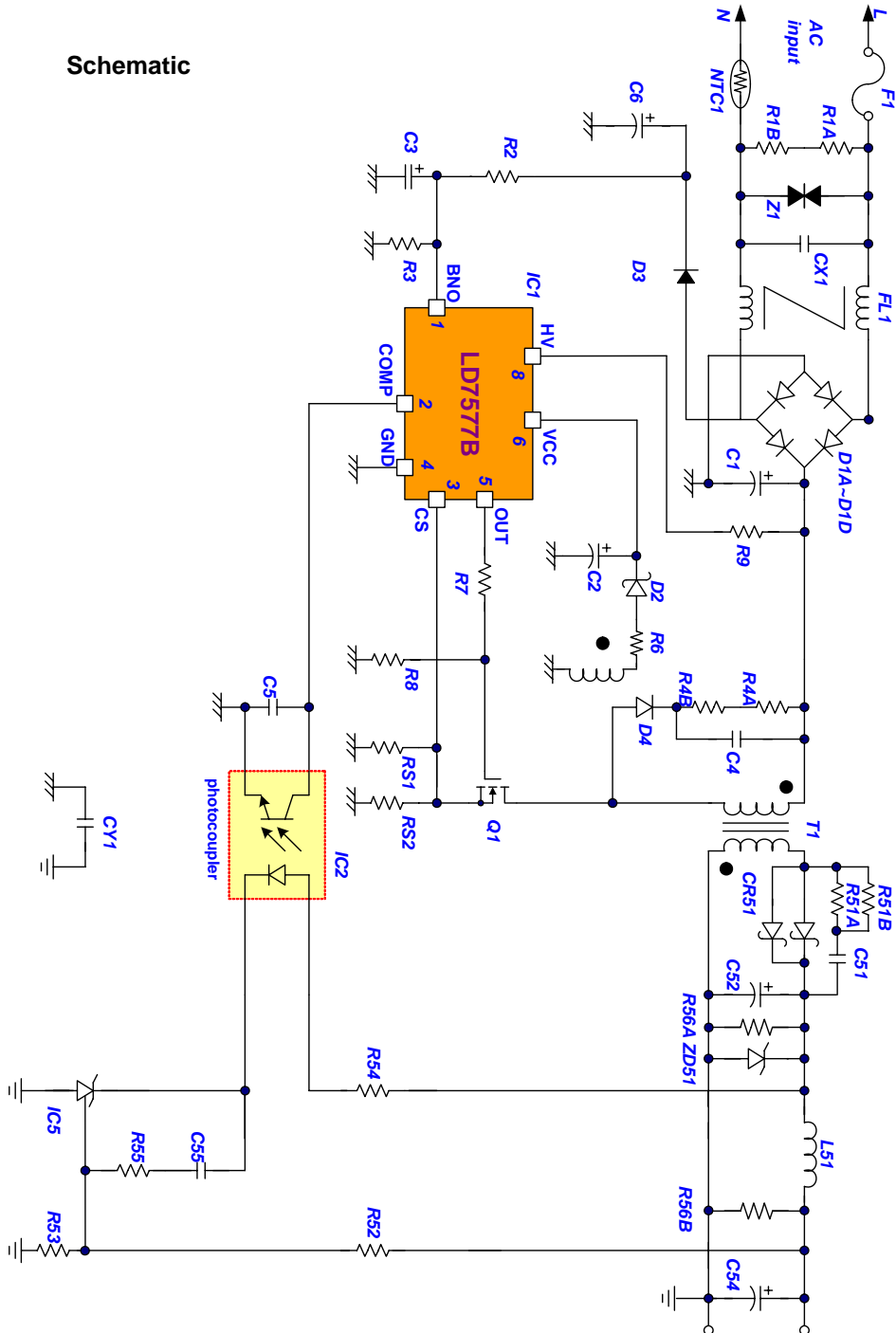

Fig. 24

## Reference Application Circuit

Schematic



## Package Information

SOP-8

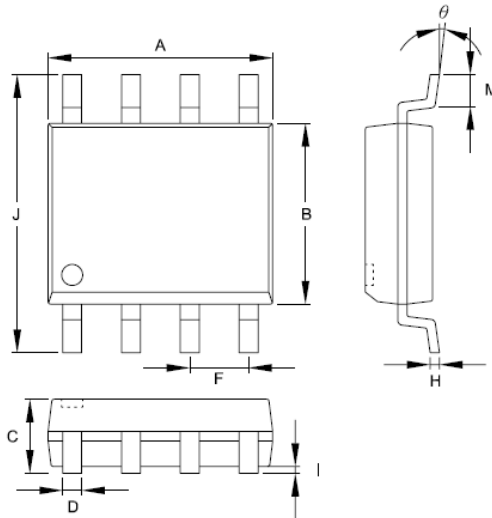

Symbol	Dimension in Millimeters		Dimensions in Inches	
	Min	Max	Min	Max
A	4.801	5.004	0.189	0.197
B	3.810	3.988	0.150	0.157
C	1.346	1.753	0.053	0.069
D	0.330	0.508	0.013	0.020
F	1.194	1.346	0.047	0.053
H	0.178	0.229	0.007	0.009
I	0.102	0.254	0.004	0.010
J	5.791	6.198	0.228	0.244
M	0.406	1.270	0.016	0.050
$\theta$	0°	8°	0°	8°



## Package Information

DIP-8

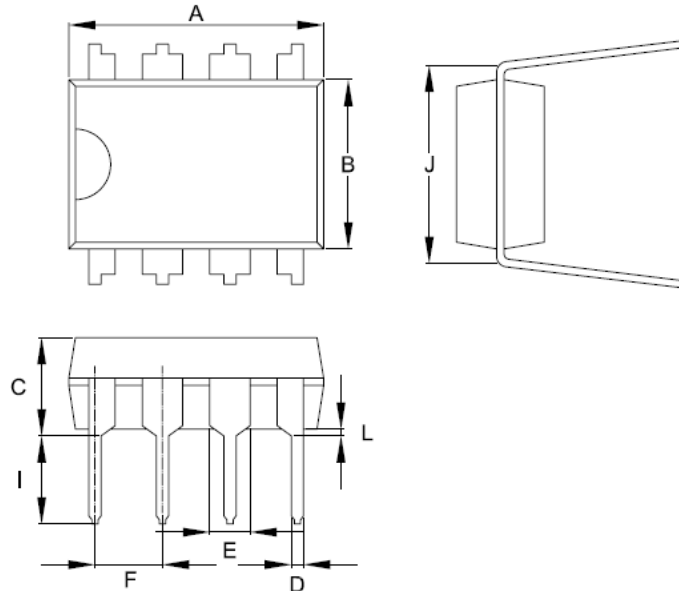

Symbol	Dimension in Millimeters		Dimensions in Inches	
	Min	Max	Min	Max
A	9.017	10.160	0.355	0.400
B	6.096	7.112	0.240	0.280
C	-----	5.334	-----	0.210
D	0.356	0.584	0.014	0.023
E	1.143	1.778	0.045	0.070
F	2.337	2.743	0.092	0.108
I	2.921	3.556	0.115	0.140
J	7.366	8.255	0.29	0.325
L	0.381	-----	0.015	-----

### Important Notice

Leadtrend Technology Corp. reserves the right to make changes or corrections to its products at any time without notice. Customers should verify the datasheets are current and complete before placing order.

**Revision History**

Rev.	Date	Change Notice
00	7/13/2009	Original specification.