

DATA SHEET

TJA1050 High speed CAN transceiver

Product specification
Supersedes data of 2002 May 16

2003 Oct 22

High speed CAN transceiver

TJA1050

FEATURES

- Fully compatible with the "ISO 11898" standard
- High speed (up to 1 Mbaud)
- Very low ElectroMagnetic Emission (EME)
- Differential receiver with wide common-mode range for high ElectroMagnetic Immunity (EMI)
- An unpowered node does not disturb the bus lines
- Transmit Data (TXD) dominant time-out function
- Silent mode in which the transmitter is disabled
- Bus pins protected against transients in an automotive environment
- Input levels compatible with 3.3 V and 5 V devices
- Thermally protected
- Short-circuit proof to battery and to ground
- At least 110 nodes can be connected.

GENERAL DESCRIPTION

The TJA1050 is the interface between the Controller Area Network (CAN) protocol controller and the physical bus. The device provides differential transmit capability to the bus and differential receive capability to the CAN controller.

The TJA1050 is the third Philips high-speed CAN transceiver after the PCA82C250 and the PCA82C251. The most important differences are:

- Much lower electromagnetic emission due to optimal matching of the output signals CANH and CANL
- Improved behaviour in case of an unpowered node
- No standby mode.

This makes the TJA1050 eminently suitable for use in nodes that are in a power-down situation in partially powered networks.

QUICK REFERENCE DATA

SYMBOL	PARAMETER	CONDITIONS	MIN.	MAX.	UNIT
V_{CC}	supply voltage		4.75	5.25	V
V_{CANH}	DC voltage at pin CANH	$0 < V_{CC} < 5.25$ V; no time limit	-27	+40	V
V_{CANL}	DC voltage at pin CANL	$0 < V_{CC} < 5.25$ V; no time limit	-27	+40	V
$V_{i(dif)(bus)}$	differential bus input voltage	dominant	1.5	3	V
$t_{PD(TXD-RXD)}$	propagation delay TXD to RXD	$V_S = 0$ V; see Fig.7	-	250	ns
T_{vj}	virtual junction temperature		-40	+150	°C

ORDERING INFORMATION

TYPE NUMBER	PACKAGE		
	NAME	DESCRIPTION	VERSION
TJA1050T	SO8	plastic small outline package; 8 leads; body width 3.9 mm	SOT96-1
TJA1050U	-	bare die; die dimensions 1700 × 1280 × 380 μm	-

High speed CAN transceiver

TJA1050

BLOCK DIAGRAM

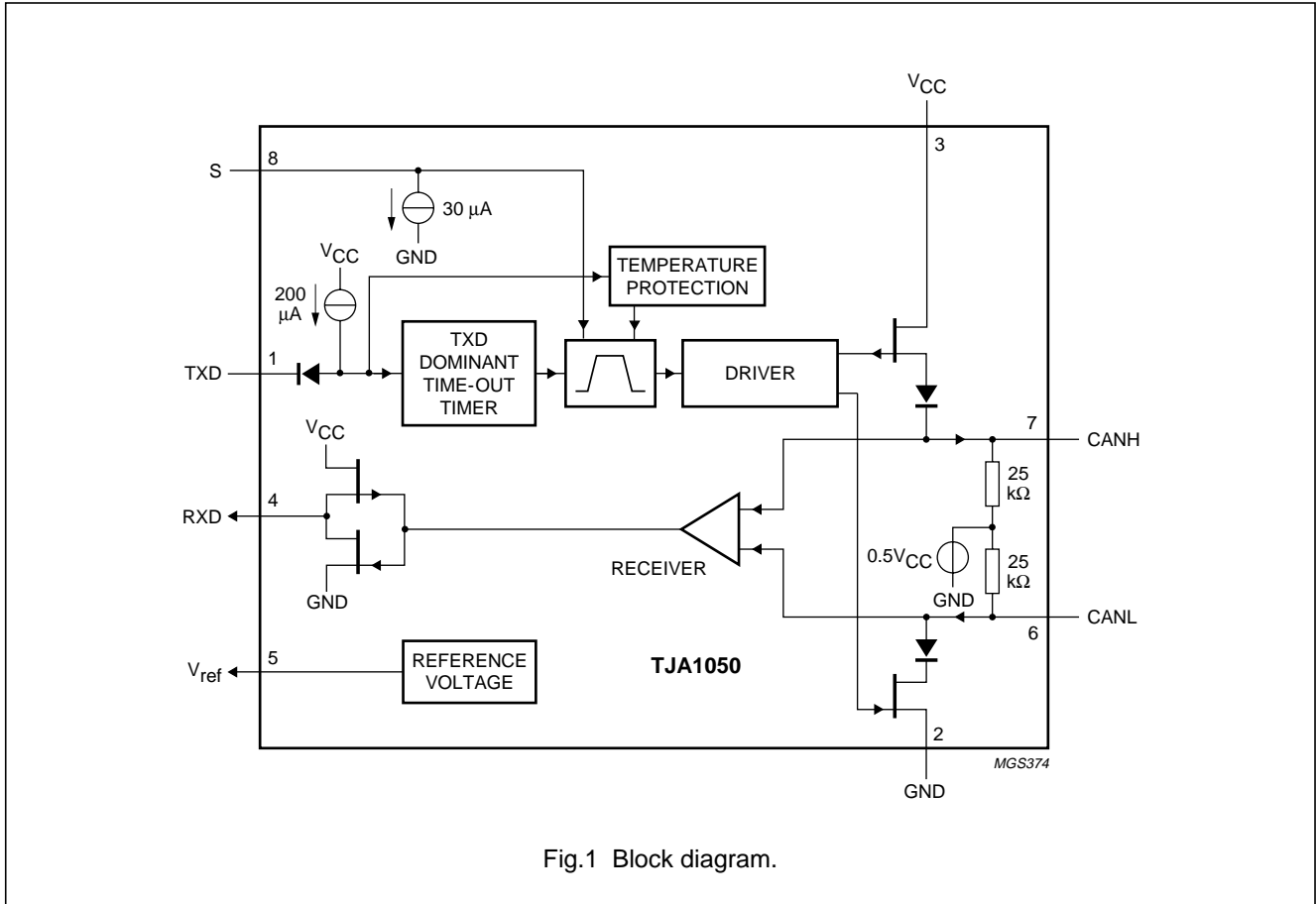

PINNING

SYMBOL	PIN	DESCRIPTION
TXD	1	transmit data input; reads in data from the CAN controller to the bus line drivers
GND	2	ground
V _{CC}	3	supply voltage
RXD	4	receive data output; reads out data from the bus lines to the CAN controller
V _{ref}	5	reference voltage output
CANL	6	LOW-level CAN bus line
CANH	7	HIGH-level CAN bus line
S	8	select input for high-speed mode or silent mode

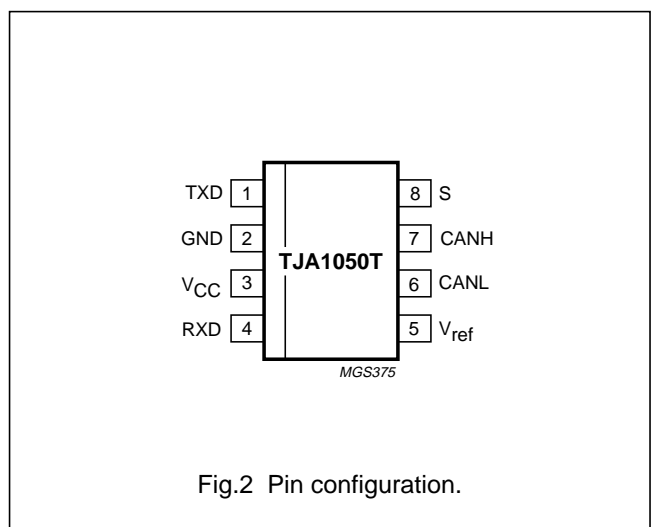

High speed CAN transceiver

TJA1050

FUNCTIONAL DESCRIPTION

The TJA1050 is the interface between the CAN protocol controller and the physical bus. It is primarily intended for high-speed automotive applications using baud rates from 60 kbaud up to 1 Mbaud. It provides differential transmit capability to the bus and differential receiver capability to the CAN protocol controller. It is fully compatible to the "ISO 11898" standard.

A current-limiting circuit protects the transmitter output stage from damage caused by accidental short-circuit to either positive or negative supply voltage, although power dissipation increases during this fault condition.

A thermal protection circuit protects the IC from damage by switching off the transmitter if the junction temperature exceeds a value of approximately 165 °C. Because the transmitter dissipates most of the power, the power dissipation and temperature of the IC is reduced. All other IC functions continue to operate. The transmitter off-state resets when pin TXD goes HIGH. The thermal protection circuit is particularly needed when a bus line short-circuits.

The pins CANH and CANL are protected from automotive electrical transients (according to "ISO 7637"; see Fig.4).

Control pin S allows two operating modes to be selected: high-speed mode or silent mode.

The high-speed mode is the normal operating mode and is selected by connecting pin S to ground. It is the default mode if pin S is not connected. However, to ensure EMI performance in applications using only the high-speed mode, it is recommended that pin S is connected to ground.

In the silent mode, the transmitter is disabled. All other IC functions continue to operate. The silent mode is selected by connecting pin S to V_{CC} and can be used to prevent network communication from being blocked, due to a CAN controller which is out of control.

A 'TXD dominant time-out' timer circuit prevents the bus lines being driven to a permanent dominant state (blocking all network communication) if pin TXD is forced permanently LOW by a hardware and/or software application failure. The timer is triggered by a negative edge on pin TXD. If the duration of the LOW-level on pin TXD exceeds the internal timer value, the transmitter is disabled, driving the bus into a recessive state. The timer is reset by a positive edge on pin TXD.

Table 1 Function table of the CAN transceiver; X = don't care

V_{CC}	TXD	S	CANH	CANL	BUS STATE	RXD
4.75 V to 5.25 V	LOW	LOW (or floating)	HIGH	LOW	dominant	LOW
4.75 V to 5.25 V	X	HIGH	$0.5V_{CC}$	$0.5V_{CC}$	recessive	HIGH
4.75 V to 5.25 V	HIGH (or floating)	X	$0.5V_{CC}$	$0.5V_{CC}$	recessive	HIGH
<2 V (not powered)	X	X	$0 V < V_{CANH} < V_{CC}$	$0 V < V_{CANL} < V_{CC}$	recessive	X
$2 V < V_{CC} < 4.75 V$	>2 V	X	$0 V < V_{CANH} < V_{CC}$	$0 V < V_{CANL} < V_{CC}$	recessive	X

High speed CAN transceiver

TJA1050

LIMITING VALUES

In accordance with the Absolute Maximum Rating System (IEC 60134). All voltages are referenced to GND (pin 2). Positive currents flow into the IC.

SYMBOL	PARAMETER	CONDITIONS	MIN.	MAX.	UNIT
V_{CC}	supply voltage		-0.3	+6	V
V_{CANH}	DC voltage at pin CANH	$0 < V_{CC} < 5.25$ V; no time limit	-27	+40	V
V_{CANL}	DC voltage at pin CANL	$0 < V_{CC} < 5.25$ V; no time limit	-27	+40	V
V_{TXD}	DC voltage at pin TXD		-0.3	$V_{CC} + 0.3$	V
V_{RXD}	DC voltage at pin RXD		-0.3	$V_{CC} + 0.3$	V
V_{ref}	DC voltage at pin V_{ref}		-0.3	$V_{CC} + 0.3$	V
V_S	DC voltage at pin S		-0.3	$V_{CC} + 0.3$	V
$V_{trt(CANH)}$	transient voltage at pin CANH	note 1	-200	+200	V
$V_{trt(CANL)}$	transient voltage at pin CANL	note 1	-200	+200	V
V_{esd}	electrostatic discharge voltage at all pins	note 2	-4000	+4000	V
		note 3	-200	+200	V
T_{stg}	storage temperature		-55	+150	°C
T_{vj}	virtual junction temperature	note 4	-40	+150	°C

Notes

- The waveforms of the applied transients shall be in accordance with "ISO 7637 part 1", test pulses 1, 2, 3a and 3b (see Fig.4).
- Human body model: $C = 100$ pF and $R = 1.5$ k Ω .
- Machine model: $C = 200$ pF, $R = 10$ Ω and $L = 0.75$ μ H.
- In accordance with "IEC 60747-1". An alternative definition of T_{vj} is: $T_{vj} = T_{amb} + P \times R_{th(vj-a)}$, where $R_{th(vj-a)}$ is a fixed value to be used for the calculation of T_{vj} . The rating for T_{vj} limits the allowable combinations of power dissipation (P) and ambient temperature (T_{amb}).

THERMAL CHARACTERISTICS

According to IEC 60747-1.

SYMBOL	PARAMETER	CONDITIONS	VALUE	UNIT
$R_{th(vj-a)}$	thermal resistance from junction to ambient in SO8 package	in free air	145	K/W
$R_{th(vj-s)}$	thermal resistance from junction to substrate of bare die	in free air	50	K/W

QUALITY SPECIFICATION

Quality specification "SNW-FQ-611 part D" is applicable.

High speed CAN transceiver

TJA1050

CHARACTERISTICS

$V_{CC} = 4.75\text{ V}$ to 5.25 V ; $T_{vj} = -40\text{ }^{\circ}\text{C}$ to $+150\text{ }^{\circ}\text{C}$; $R_L = 60\ \Omega$ unless specified otherwise; all voltages are referenced to GND (pin 2); positive currents flow into the IC; see notes 1 and 2.

SYMBOL	PARAMETER	CONDITIONS	MIN.	TYP.	MAX.	UNIT
Supply (pin V_{CC})						
I_{CC}	supply current	dominant; $V_{TXD} = 0\text{ V}$	25	50	75	mA
		recessive; $V_{TXD} = V_{CC}$	2.5	5	10	mA
Transmitter data input (pin TXD)						
V_{IH}	HIGH-level input voltage	output recessive	2.0	–	$V_{CC} + 0.3$	V
V_{IL}	LOW-level input voltage	output dominant	–0.3	–	+0.8	V
I_{IH}	HIGH-level input current	$V_{TXD} = V_{CC}$	–5	0	+5	μA
I_{IL}	LOW-level input current	$V_{TXD} = 0\text{ V}$	–100	–200	–300	μA
C_i	input capacitance	not tested	–	5	10	pF
Mode select input (pin S)						
V_{IH}	HIGH-level input voltage	silent mode	2.0	–	$V_{CC} + 0.3$	V
V_{IL}	LOW-level input voltage	high-speed mode	–0.3	–	+0.8	V
I_{IH}	HIGH-level input current	$V_S = 2\text{ V}$	20	30	50	μA
I_{IL}	LOW-level input current	$V_S = 0.8\text{ V}$	15	30	45	μA
Receiver data output (pin RXD)						
I_{OH}	HIGH-level output current	$V_{RXD} = 0.7V_{CC}$	–2	–6	–15	mA
I_{OL}	LOW-level output current	$V_{RXD} = 0.45\text{ V}$	2	8.5	20	mA
Reference voltage output (pin V_{ref})						
V_{ref}	reference output voltage	$-50\ \mu\text{A} < I_{Vref} < +50\ \mu\text{A}$	$0.45V_{CC}$	$0.5V_{CC}$	$0.55V_{CC}$	V
Bus lines (pins CANH and CANL)						
$V_{o(reces)(CANH)}$	recessive bus voltage at pin CANH	$V_{TXD} = V_{CC}$; no load	2.0	2.5	3.0	V
$V_{o(reces)(CANL)}$	recessive bus voltage at pin CANL	$V_{TXD} = V_{CC}$; no load	2.0	2.5	3.0	V
$I_{o(reces)(CANH)}$	recessive output current at pin CANH	$-27\text{ V} < V_{CANH} < +32\text{ V}$; $0\text{ V} < V_{CC} < 5.25\text{ V}$	–2.0	–	+2.5	mA
$I_{o(reces)(CANL)}$	recessive output current at pin CANL	$-27\text{ V} < V_{CANL} < +32\text{ V}$; $0\text{ V} < V_{CC} < 5.25\text{ V}$	–2.0	–	+2.5	mA
$V_{o(dom)(CANH)}$	dominant output voltage at pin CANH	$V_{TXD} = 0\text{ V}$	3.0	3.6	4.25	V
$V_{o(dom)(CANL)}$	dominant output voltage at pin CANL	$V_{TXD} = 0\text{ V}$	0.5	1.4	1.75	V
$V_{i(dif)(bus)}$	differential bus input voltage ($V_{CANH} - V_{CANL}$)	$V_{TXD} = 0\text{ V}$; dominant; $42.5\ \Omega < R_L < 60\ \Omega$	1.5	2.25	3.0	V
		$V_{TXD} = V_{CC}$; recessive; no load	–50	0	+50	mV

High speed CAN transceiver

TJA1050

SYMBOL	PARAMETER	CONDITIONS	MIN.	TYP.	MAX.	UNIT
$I_{o(sc)}(CANH)$	short-circuit output current at pin CANH	$V_{CANH} = 0\text{ V}; V_{TXD} = 0\text{ V}$	-45	-70	-95	mA
$I_{o(sc)}(CANL)$	short-circuit output current at pin CANL	$V_{CANL} = 36\text{ V}; V_{TXD} = 0\text{ V}$	45	70	100	mA
$V_{i(dif)}(th)$	differential receiver threshold voltage	$-12\text{ V} < V_{CANL} < +12\text{ V}; -12\text{ V} < V_{CANH} < +12\text{ V};$ see Fig.5	0.5	0.7	0.9	V
$V_{i(dif)}(hys)$	differential receiver input voltage hysteresis	$-12\text{ V} < V_{CANL} < +12\text{ V}; -12\text{ V} < V_{CANH} < +12\text{ V};$ see Fig.5	50	70	100	mV
$R_{i(cm)}(CANH)$	common mode input resistance at pin CANH		15	25	35	k Ω
$R_{i(cm)}(CANL)$	common mode input resistance at pin CANL		15	25	35	k Ω
$R_{i(cm)}(m)$	matching between pin CANH and pin CANL common mode input resistance	$V_{CANH} = V_{CANL}$	-3	0	+3	%
$R_{i(dif)}$	differential input resistance		25	50	75	k Ω
$C_{i}(CANH)$	input capacitance at pin CANH	$V_{TXD} = V_{CC};$ not tested	-	7.5	20	pF
$C_{i}(CANL)$	input capacitance at pin CANL	$V_{TXD} = V_{CC};$ not tested	-	7.5	20	pF
$C_{i(dif)}$	differential input capacitance	$V_{TXD} = V_{CC};$ not tested	-	3.75	10	pF
$I_{LI}(CANH)$	input leakage current at pin CANH	$V_{CC} = 0\text{ V}; V_{CANH} = 5\text{ V}$	100	170	250	μA
$I_{LI}(CANL)$	input leakage current at pin CANL	$V_{CC} = 0\text{ V}; V_{CANL} = 5\text{ V}$	100	170	250	μA
Thermal shutdown						
$T_{j(sd)}$	shutdown junction temperature		155	165	180	$^{\circ}\text{C}$
Timing characteristics (see Figs.6 and 7)						
$t_{d}(TXD\text{-}BUSon)$	delay TXD to bus active	$V_S = 0\text{ V}$	25	55	110	ns
$t_{d}(TXD\text{-}BUSoff)$	delay TXD to bus inactive	$V_S = 0\text{ V}$	25	60	95	ns
$t_{d}(BUSon\text{-}RXD)$	delay bus active to RXD	$V_S = 0\text{ V}$	20	50	110	ns
$t_{d}(BUSoff\text{-}RXD)$	delay bus inactive to RXD	$V_S = 0\text{ V}$	45	95	155	ns
$t_{dom}(TXD)$	TXD dominant time for time-out	$V_{TXD} = 0\text{ V}$	250	450	750	μs

Notes

- All parameters are guaranteed over the virtual junction temperature range by design, but only 100 % tested at 125 $^{\circ}\text{C}$ ambient temperature for dies on wafer level and in addition to this 100 % tested at 25 $^{\circ}\text{C}$ ambient temperature for cased products, unless specified otherwise.
- For bare die, all parameters are only guaranteed if the backside of the bare die is connected to ground.

High speed CAN transceiver

TJA1050

APPLICATION AND TEST INFORMATION

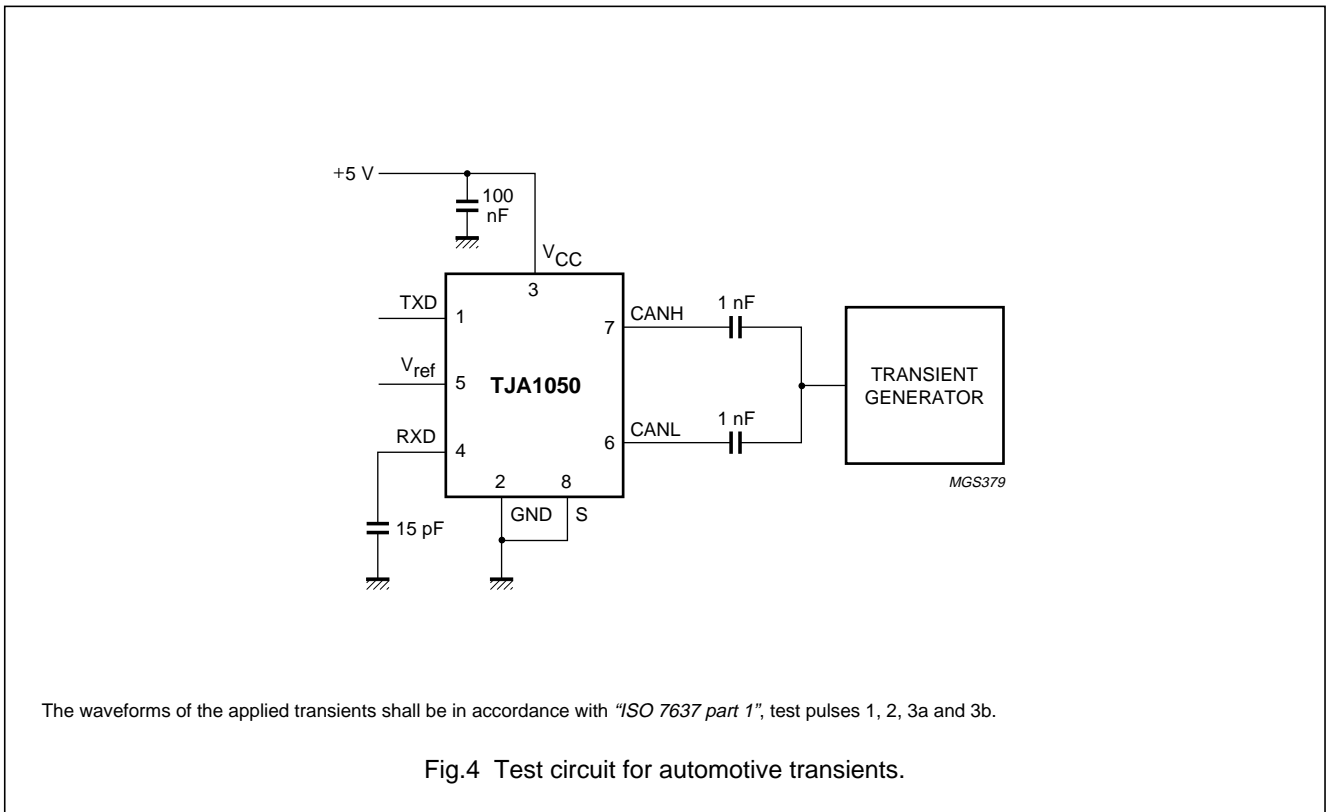
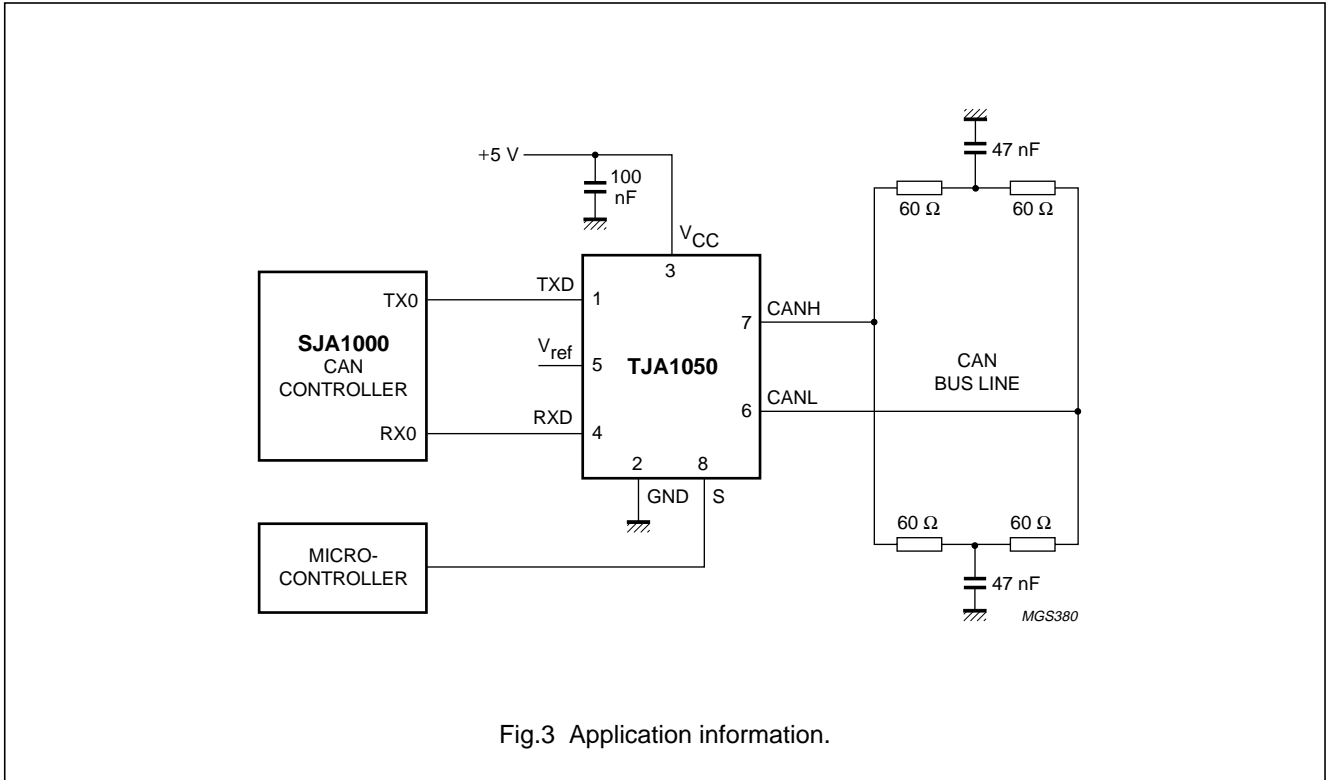

High speed CAN transceiver

TJA1050

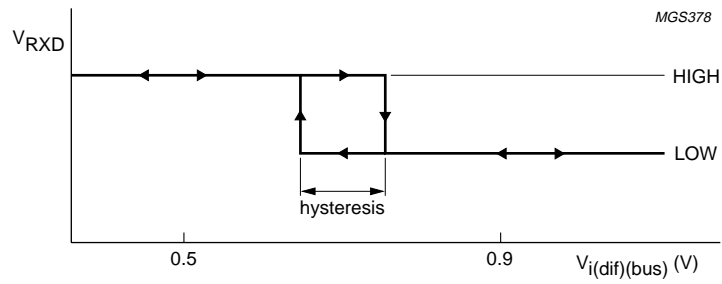

Fig.5 Hysteresis of the receiver.

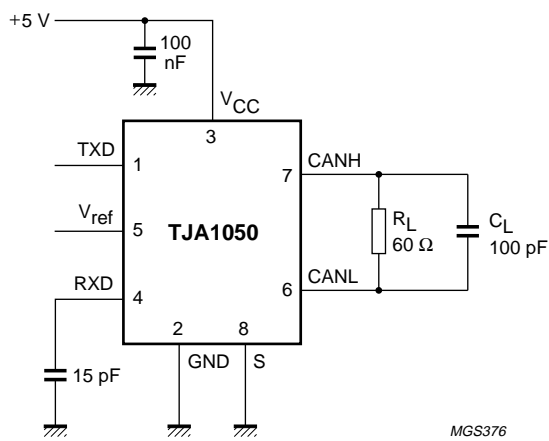
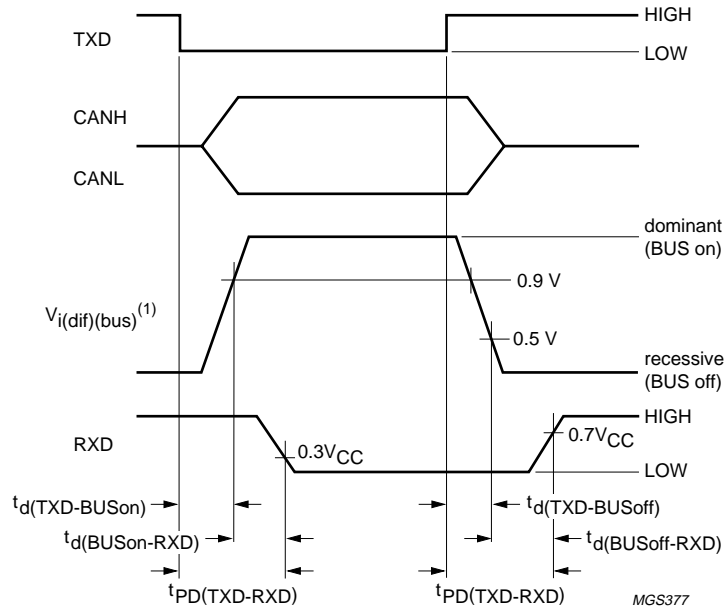

Fig.6 Test circuit for timing characteristics.

High speed CAN transceiver

TJA1050



(1) $V_{i(dif)(bus)} = V_{CANH} - V_{CANL}$.

Fig.7 Timing diagram for AC characteristics.

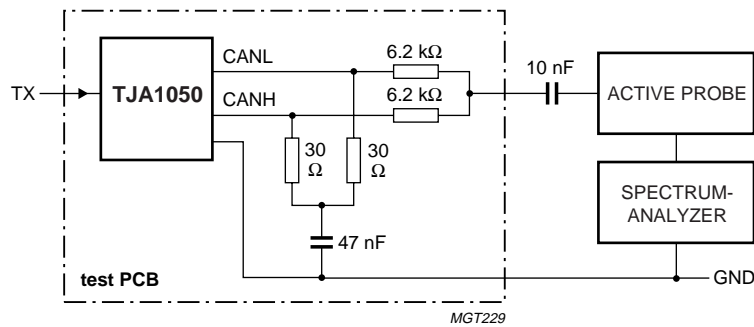
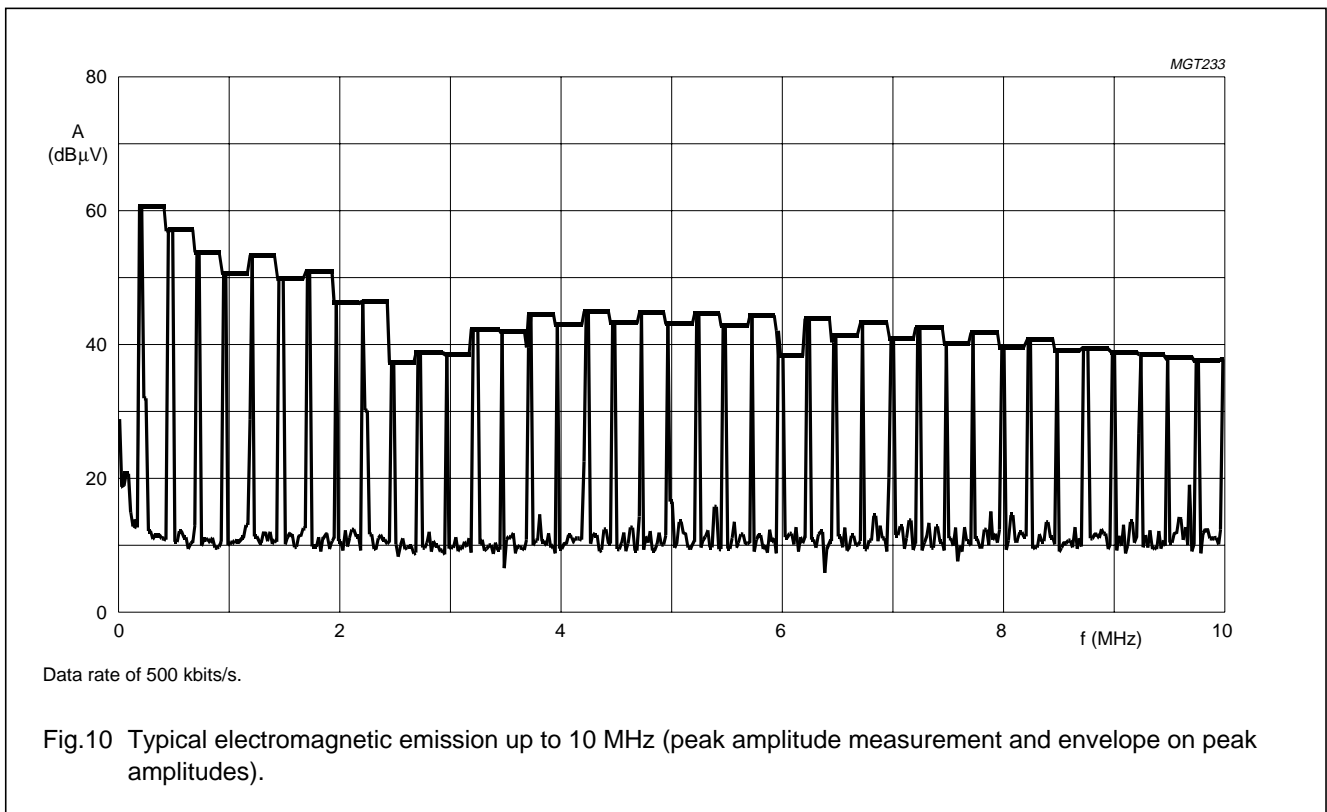
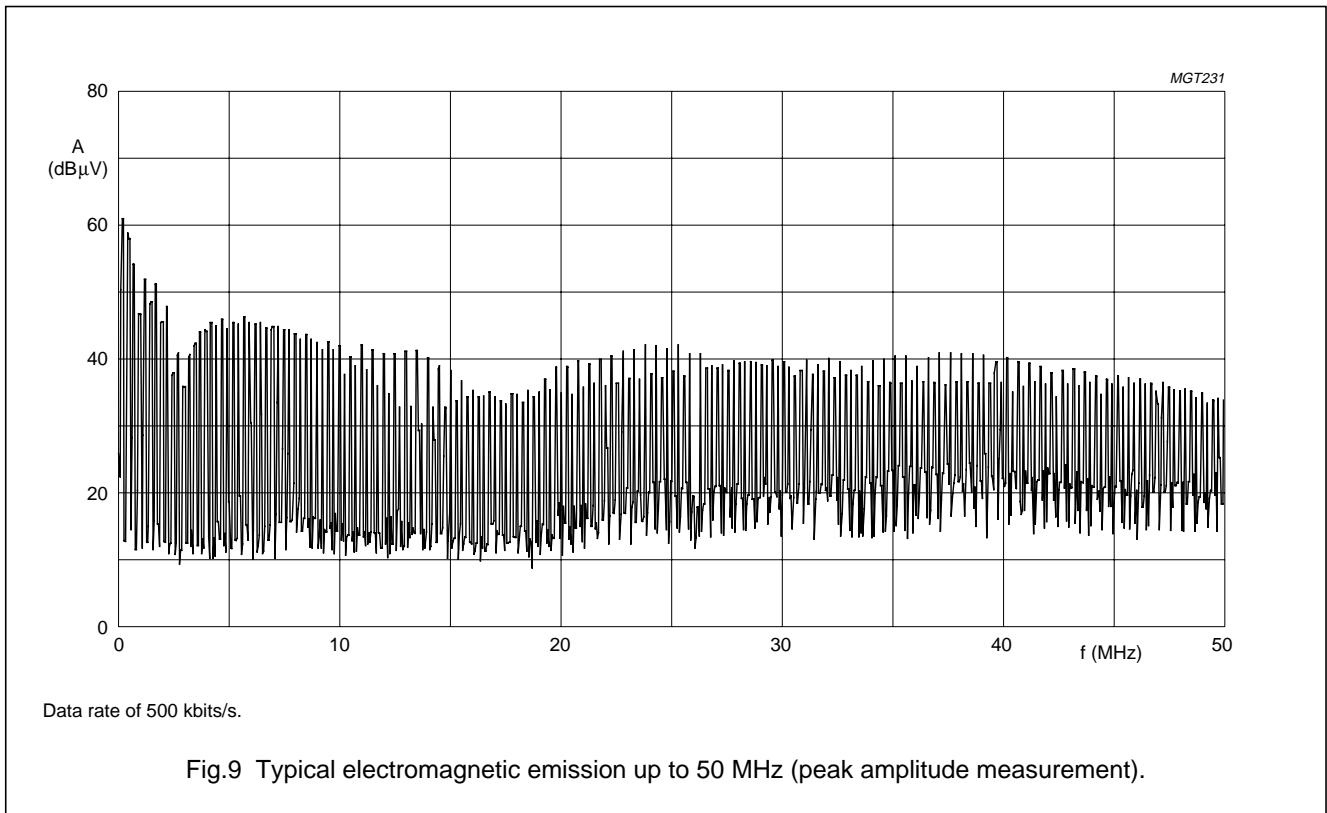

Fig.8 Basic test set-up (with split termination) for electromagnetic emission measurement (see Figs 9 and 10).

High speed CAN transceiver

TJA1050



High speed CAN transceiver

TJA1050

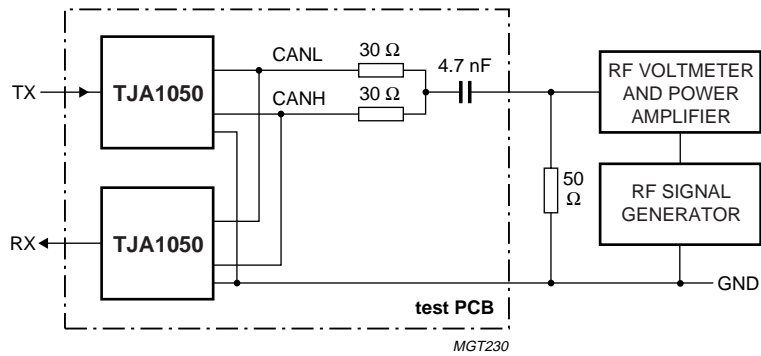

Fig.11 Basic test set-up for electromagnetic immunity measurement (see Fig.12).

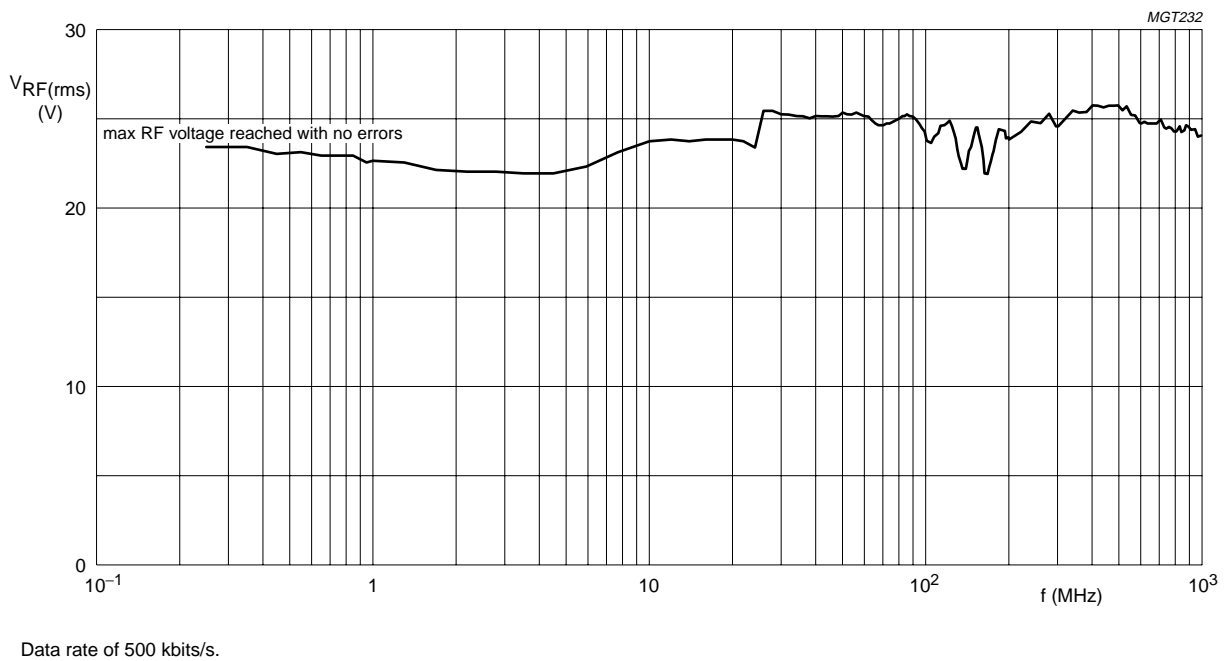

Fig.12 Typical electromagnetic immunity.

High speed CAN transceiver

TJA1050

BONDING PAD LOCATIONS

SYMBOL	PAD	COORDINATES ⁽¹⁾	
		x	y
TXD	1	103	103
GND	2	740	85
V _{CC}	3	886.5	111
RXD	4	1371.5	111
V _{ref}	5	1394	1094
CANL	6	998	1115
CANH	7	538.5	1115
S	8	103	1097

Note

1. All x/y coordinates represent the position of the centre of each pad (in μm) with respect to the lefthand bottom corner of the top aluminium layer (see Fig.13).

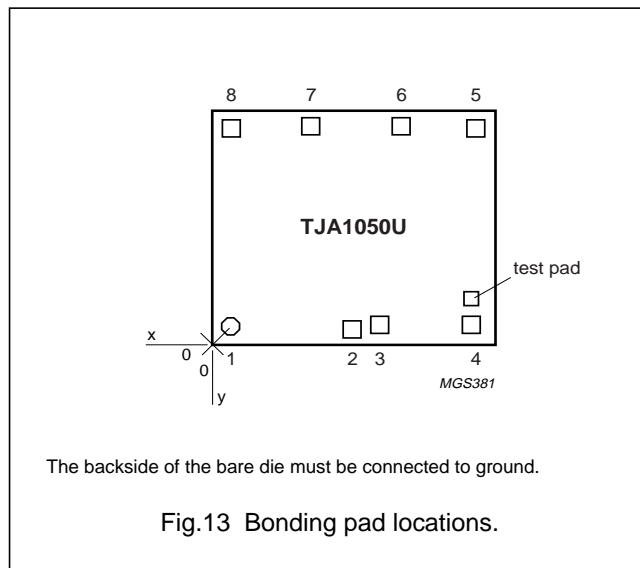

High speed CAN transceiver

TJA1050

PACKAGE OUTLINE

S08: plastic small outline package; 8 leads; body width 3.9 mm

SOT96-1

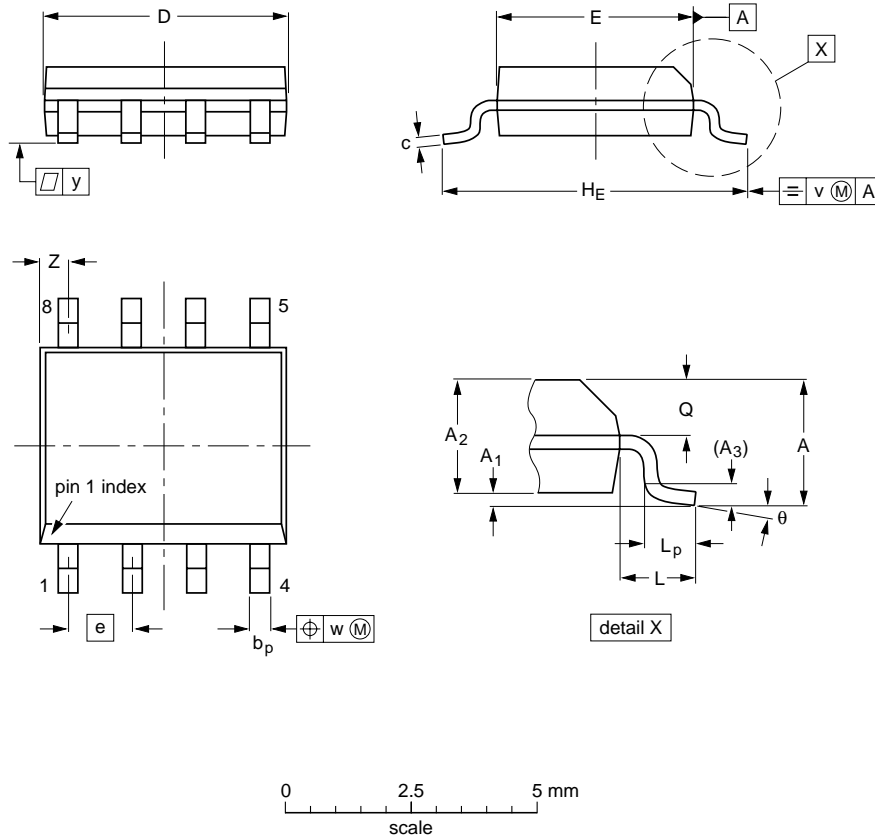

DIMENSIONS (inch dimensions are derived from the original mm dimensions)

UNIT	A max.	A ₁	A ₂	A ₃	b _p	c	D ⁽¹⁾	E ⁽²⁾	e	H _E	L	L _p	Q	v	w	y	z ⁽¹⁾	θ
mm	1.75	0.25 0.10	1.45 1.25	0.25	0.49 0.36	0.25 0.19	5.0 4.8	4.0 3.8	1.27	6.2 5.8	1.05	1.0 0.4	0.7 0.6	0.25	0.25	0.1	0.7 0.3	8° 0°
inches	0.069	0.010 0.004	0.057 0.049	0.01	0.019 0.014	0.0100 0.0075	0.20 0.19	0.16 0.15	0.05	0.244 0.228	0.041	0.039 0.016	0.028 0.024	0.01	0.01	0.004	0.028 0.012	

Notes

1. Plastic or metal protrusions of 0.15 mm (0.006 inch) maximum per side are not included.
2. Plastic or metal protrusions of 0.25 mm (0.01 inch) maximum per side are not included.

OUTLINE VERSION	REFERENCES				EUROPEAN PROJECTION	ISSUE DATE
	IEC	JEDEC	JEITA			
SOT96-1	076E03	MS-012				99-12-27 03-02-18

High speed CAN transceiver

TJA1050

SOLDERING

Introduction to soldering surface mount packages

This text gives a very brief insight to a complex technology. A more in-depth account of soldering ICs can be found in our *"Data Handbook IC26; Integrated Circuit Packages"* (document order number 9398 652 90011).

There is no soldering method that is ideal for all surface mount IC packages. Wave soldering can still be used for certain surface mount ICs, but it is not suitable for fine pitch SMDs. In these situations reflow soldering is recommended.

Reflow soldering

Reflow soldering requires solder paste (a suspension of fine solder particles, flux and binding agent) to be applied to the printed-circuit board by screen printing, stencilling or pressure-syringe dispensing before package placement. Driven by legislation and environmental forces the worldwide use of lead-free solder pastes is increasing.

Several methods exist for reflowing; for example, convection or convection/infrared heating in a conveyor type oven. Throughput times (preheating, soldering and cooling) vary between 100 and 200 seconds depending on heating method.

Typical reflow peak temperatures range from 215 to 270 °C depending on solder paste material. The top-surface temperature of the packages should preferably be kept:

- below 220 °C (SnPb process) or below 245 °C (Pb-free process)
 - for all BGA and SSOP-T packages
 - for packages with a thickness ≥ 2.5 mm
 - for packages with a thickness < 2.5 mm and a volume ≥ 350 mm³ so called thick/large packages.
- below 235 °C (SnPb process) or below 260 °C (Pb-free process) for packages with a thickness < 2.5 mm and a volume < 350 mm³ so called small/thin packages.

Moisture sensitivity precautions, as indicated on packing, must be respected at all times.

Wave soldering

Conventional single wave soldering is not recommended for surface mount devices (SMDs) or printed-circuit boards with a high component density, as solder bridging and non-wetting can present major problems.

To overcome these problems the double-wave soldering method was specifically developed.

If wave soldering is used the following conditions must be observed for optimal results:

- Use a double-wave soldering method comprising a turbulent wave with high upward pressure followed by a smooth laminar wave.
- For packages with leads on two sides and a pitch (e):
 - larger than or equal to 1.27 mm, the footprint longitudinal axis is **preferred** to be parallel to the transport direction of the printed-circuit board;
 - smaller than 1.27 mm, the footprint longitudinal axis **must** be parallel to the transport direction of the printed-circuit board.

The footprint must incorporate solder thieves at the downstream end.

- For packages with leads on four sides, the footprint must be placed at a 45° angle to the transport direction of the printed-circuit board. The footprint must incorporate solder thieves downstream and at the side corners.

During placement and before soldering, the package must be fixed with a droplet of adhesive. The adhesive can be applied by screen printing, pin transfer or syringe dispensing. The package can be soldered after the adhesive is cured.

Typical dwell time of the leads in the wave ranges from 3 to 4 seconds at 250 °C or 265 °C, depending on solder material applied, SnPb or Pb-free respectively.

A mildly-activated flux will eliminate the need for removal of corrosive residues in most applications.

Manual soldering

Fix the component by first soldering two diagonally-opposite end leads. Use a low voltage (24 V or less) soldering iron applied to the flat part of the lead. Contact time must be limited to 10 seconds at up to 300 °C.

When using a dedicated tool, all other leads can be soldered in one operation within 2 to 5 seconds between 270 and 320 °C.

High speed CAN transceiver

TJA1050

Suitability of surface mount IC packages for wave and reflow soldering methods

PACKAGE ⁽¹⁾	SOLDERING METHOD	
	WAVE	REFLOW ⁽²⁾
BGA, LBGA, LFBGA, SQFP, SSOP-T ⁽³⁾ , TFBGA, VFBGA	not suitable	suitable
DHVQFN, HBCC, HBGA, HLQFP, HSQFP, HSOP, HTQFP, HTSSOP, HVQFN, HVSON, SMS	not suitable ⁽⁴⁾	suitable
PLCC ⁽⁵⁾ , SO, SOJ	suitable	suitable
LQFP, QFP, TQFP	not recommended ⁽⁵⁾⁽⁶⁾	suitable
SSOP, TSSOP, VSO, VSSOP	not recommended ⁽⁷⁾	suitable
PMFP ⁽⁸⁾	not suitable	not suitable

Notes

- For more detailed information on the BGA packages refer to the “(LF)BGA Application Note” (AN01026); order a copy from your Philips Semiconductors sales office.
- All surface mount (SMD) packages are moisture sensitive. Depending upon the moisture content, the maximum temperature (with respect to time) and body size of the package, there is a risk that internal or external package cracks may occur due to vaporization of the moisture in them (the so called popcorn effect). For details, refer to the Drypack information in the “Data Handbook IC26; Integrated Circuit Packages; Section: Packing Methods”.
- These transparent plastic packages are extremely sensitive to reflow soldering conditions and must on no account be processed through more than one soldering cycle or subjected to infrared reflow soldering with peak temperature exceeding $217\text{ °C} \pm 10\text{ °C}$ measured in the atmosphere of the reflow oven. The package body peak temperature must be kept as low as possible.
- These packages are not suitable for wave soldering. On versions with the heatsink on the bottom side, the solder cannot penetrate between the printed-circuit board and the heatsink. On versions with the heatsink on the top side, the solder might be deposited on the heatsink surface.
- If wave soldering is considered, then the package must be placed at a 45° angle to the solder wave direction. The package footprint must incorporate solder thieves downstream and at the side corners.
- Wave soldering is suitable for LQFP, TQFP and QFP packages with a pitch (e) larger than 0.8 mm; it is definitely not suitable for packages with a pitch (e) equal to or smaller than 0.65 mm.
- Wave soldering is suitable for SSOP, TSSOP, VSO and VSSOP packages with a pitch (e) equal to or larger than 0.65 mm; it is definitely not suitable for packages with a pitch (e) equal to or smaller than 0.5 mm.
- Hot bar or manual soldering is suitable for PMFP packages.

REVISION HISTORY

REV	DATE	CPCN	DESCRIPTION
4	20031013	–	Product specification (9397 750 12157) Modification: <ul style="list-style-type: none"> Added recommendation to connect unused pin S to ground Added Chapter REVISION HISTORY
3	20020516	–	Product specification (9397 750 09778)

High speed CAN transceiver

TJA1050

DATA SHEET STATUS

LEVEL	DATA SHEET STATUS ⁽¹⁾	PRODUCT STATUS ⁽²⁾⁽³⁾	DEFINITION
I	Objective data	Development	This data sheet contains data from the objective specification for product development. Philips Semiconductors reserves the right to change the specification in any manner without notice.
II	Preliminary data	Qualification	This data sheet contains data from the preliminary specification. Supplementary data will be published at a later date. Philips Semiconductors reserves the right to change the specification without notice, in order to improve the design and supply the best possible product.
III	Product data	Production	This data sheet contains data from the product specification. Philips Semiconductors reserves the right to make changes at any time in order to improve the design, manufacturing and supply. Relevant changes will be communicated via a Customer Product/Process Change Notification (CPCN).

Notes

1. Please consult the most recently issued data sheet before initiating or completing a design.
2. The product status of the device(s) described in this data sheet may have changed since this data sheet was published. The latest information is available on the Internet at URL <http://www.semiconductors.philips.com>.
3. For data sheets describing multiple type numbers, the highest-level product status determines the data sheet status.

DEFINITIONS

Short-form specification — The data in a short-form specification is extracted from a full data sheet with the same type number and title. For detailed information see the relevant data sheet or data handbook.

Limiting values definition — Limiting values given are in accordance with the Absolute Maximum Rating System (IEC 60134). Stress above one or more of the limiting values may cause permanent damage to the device. These are stress ratings only and operation of the device at these or at any other conditions above those given in the Characteristics sections of the specification is not implied. Exposure to limiting values for extended periods may affect device reliability.

Application information — Applications that are described herein for any of these products are for illustrative purposes only. Philips Semiconductors make no representation or warranty that such applications will be suitable for the specified use without further testing or modification.

DISCLAIMERS

Life support applications — These products are not designed for use in life support appliances, devices, or systems where malfunction of these products can reasonably be expected to result in personal injury. Philips Semiconductors customers using or selling these products for use in such applications do so at their own risk and agree to fully indemnify Philips Semiconductors for any damages resulting from such application.

Right to make changes — Philips Semiconductors reserves the right to make changes in the products - including circuits, standard cells, and/or software - described or contained herein in order to improve design and/or performance. When the product is in full production (status 'Production'), relevant changes will be communicated via a Customer Product/Process Change Notification (CPCN). Philips Semiconductors assumes no responsibility or liability for the use of any of these products, conveys no licence or title under any patent, copyright, or mask work right to these products, and makes no representations or warranties that these products are free from patent, copyright, or mask work right infringement, unless otherwise specified.

Philips Semiconductors – a worldwide company

Contact information

For additional information please visit <http://www.semiconductors.philips.com>. Fax: +31 40 27 24825

For sales offices addresses send e-mail to: sales.addresses@www.semiconductors.philips.com.

© Koninklijke Philips Electronics N.V. 2003

SCA75

All rights are reserved. Reproduction in whole or in part is prohibited without the prior written consent of the copyright owner.

The information presented in this document does not form part of any quotation or contract, is believed to be accurate and reliable and may be changed without notice. No liability will be accepted by the publisher for any consequence of its use. Publication thereof does not convey nor imply any license under patent- or other industrial or intellectual property rights.

Printed in The Netherlands

R16/04/pp18

Date of release: 2003 Oct 22

Document order number: 9397 750 12157

Let's make things better.

**Philips
Semiconductors**



PHILIPS