

BTS 5012SDA BTS 5014SDA BTS 5016SDA

High Current PROFET™
Smart High-Side Power Switches
One Channel 12-14-16 mΩ



THE BTS 5012SDA, BTS 5014SDA, BTS 5016SDA are single channel high-side power switches (from 12 to 16 mΩ), housed in PG-T0252-5 (DPAK 5 pin) RoHS compliant packages.

The devices have all current sense and provide an embedded set of protection and diagnostic features, including ReverSave™, a function which causes the power transistor to switch on in case of reverse battery mode, reducing power dissipation.

An optimized current limitation characteristic adjusts the maximum current according to the supply voltage, making the devices particularly suitable to handle the in-rush current of lamps.

Through the current sense pin, it is possible to diagnose, with a defined fault signal, such events like overload operation, over temperature and/or short circuit shutdown.

Pin-to-pin compatibility and identical functionality enable scalability by $R_{DS(ON)}$ and related parameters; scalability is extended to the existing BTS 61xxD family.

Product Name	$R_{DS(ON)}$ $T_j = 25^\circ\text{C}$	$R_{DS(ON)}$ $T_j = 150^\circ\text{C}$	$V_{ON(CL)}$ (min)	I_{LSC} (min) $T_j = 25^\circ\text{C}$
BTS 5012SDA	12 mΩ (typ)	24 mΩ (max)	39 V	65 A @ $V_{ON} = 4$ V
BTS 5014SDA	14 mΩ (typ)	28 mΩ (max)	39 V	55 A @ $V_{ON} = 4$ V
BTS 5016SDA	16 mΩ (typ)	32 mΩ (max)	39 V	45 A @ $V_{ON} = 4$ V

Basic Features

- Scalability
- Very low standby current
- Optimized electromagnetic compatibility (EMC)
- Fast demagnetization of inductive loads
- Green product (RoHS compliant)
- AEC qualified

Protection Functions

- Short circuit protection with latch
- Overload protection
- Multi-step current limitation
- Thermal shutdown with restart
- ReverSave™, channel switches on in case of reverse polarity
- Overvoltage protection (including load dump)
- Loss of ground protection
- Loss of V_{bb} protection (with external diode for charged inductive loads)
- Electrostatic discharge protection (ESD)

Diagnosis Functions

- Proportional load current sense
- Defined fault signal in case of:
 - Overload operation
 - Overtemperature shutdown
 - Short circuit shutdown
- Open load detection in ON-state by load current sense



www.infineon.com/profet

Power Semiconductors



Never stop thinking

Block Diagram

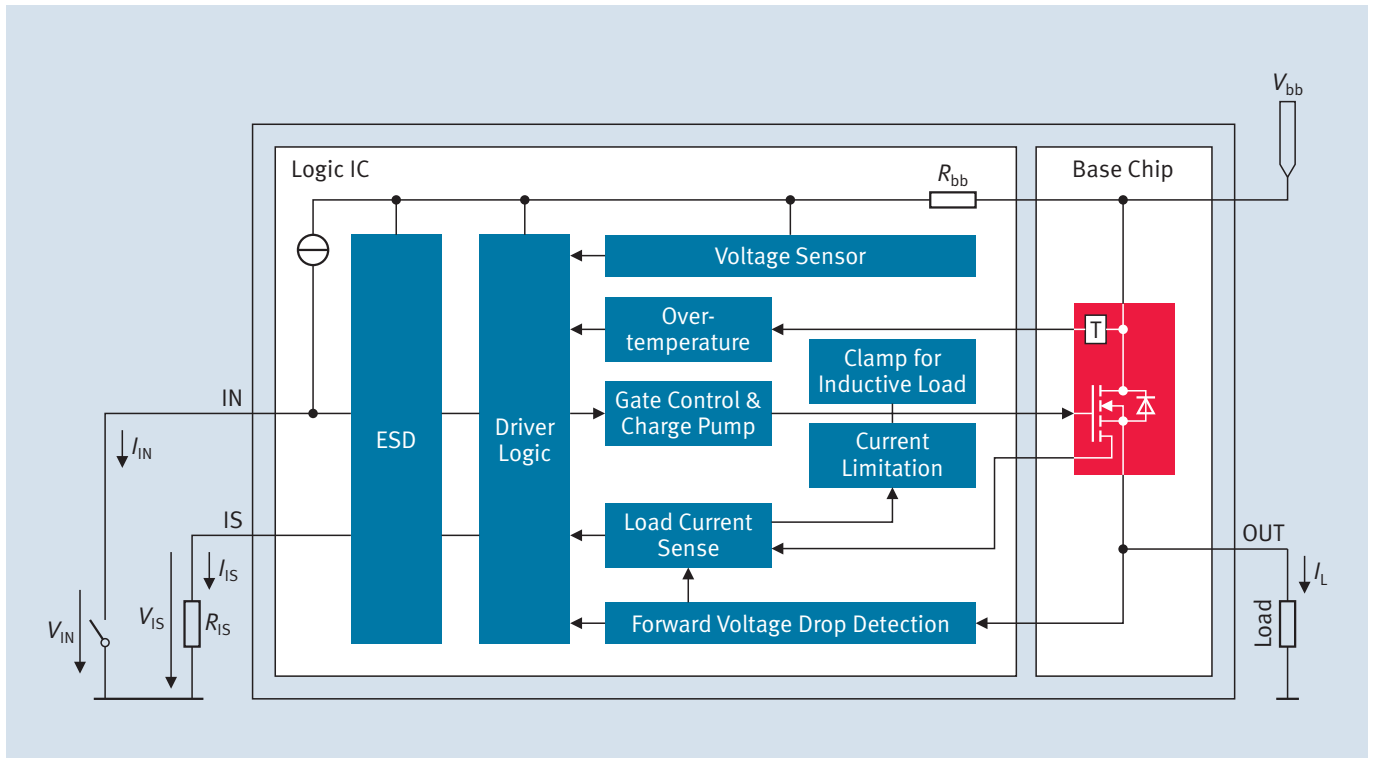

Application Example

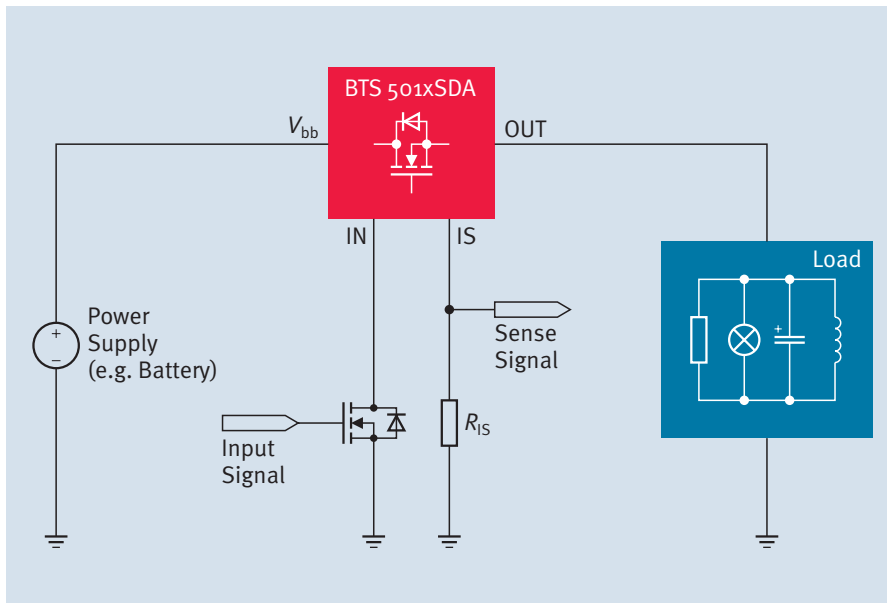

Application Examples

- All types of resistive, inductive and capacitive loads, particularly those with high in-rush currents, such as lamps, e.g.:
 - Light modules (High/Low Beam, conventional and HID, fog lights, theatre dimming)
 - Body modules
 - Seat heating
- μC compatible high side power switch with diagnostic feedback for 12 V grounded loads
- Replaces electromechanical relays, fuses and discrete circuits

How to reach us:
<http://www.infineon.com>

Published by
 Infineon Technologies AG
 81726 Munich, Germany

© 2008 Infineon Technologies AG
 All Rights Reserved.

Legal Disclaimer

The information given in this Product Brief shall in no event be regarded as a guarantee of conditions or characteristics. With respect to any examples or hints given herein, any typical values stated herein and/or any information regarding the application of the device, Infineon Technologies hereby disclaims any and all warranties and liabilities of any kind, including without limitation, warranties of non-infringement of intellectual property rights of any third party.

Information

For further information on technology, delivery terms and conditions and prices, please contact the nearest Infineon Technologies Office (www.infineon.com).

Warnings

Due to technical requirements, components may contain dangerous substances. For information on the types in question, please contact the nearest Infineon Technologies Office.

Infineon Technologies components may be used in life-support devices or systems only with the express written approval of Infineon Technologies, if a failure of such components can reasonably be expected to cause the failure of that life-support device or system or to affect the safety or effectiveness of that device or system. Life support devices or systems are intended to be implanted in the human body or to support and/or maintain and sustain and/or protect human life. If they fail, it is reasonable to assume that the health of the user or other persons may be endangered.