



STB30N65M5, STF30N65M5, STI30N65M5 STP30N65M5, STW30N65M5

N-channel 650 V, 0.125 Ω , 22 A, MDmesh™ V Power MOSFET
D²PAK, TO-220FP, I²PAK, TO-220, TO-247

Features

| Order codes | V _{DSS} @ T _{JMAX} | R _{DS(on)} max. | I _D |
|-------------|---|--------------------------|---------------------|
| STB30N65M5 | 710 V | < 0.139 Ω | 22 A |
| STF30N65M5 | 710 V | < 0.139 Ω | 22 A ⁽¹⁾ |
| STI30N65M5 | 710 V | < 0.139 Ω | 22 A |
| STP30N65M5 | 710 V | < 0.139 Ω | 22 A |
| STW30N65M5 | 710 V | < 0.139 Ω | 22 A |

1. Limited only by maximum temperature allowed

- Worldwide best R_{DS(on)}*area
- Higher V_{DSS} rating
- Excellent switching performance
- Easy to drive
- 100% avalanche tested
- High dv/dt capability

Applications

- Switching applications

Description

These devices are N-channel MDmesh™ V Power MOSFETs based on an innovative proprietary vertical process technology, which is combined with STMicroelectronics' well-known PowerMESH™ horizontal layout structure. The resulting product has extremely low on-resistance, which is unmatched among silicon-based Power MOSFETs, making it especially suitable for applications which require superior power density and outstanding efficiency.

Table 1. Device summary

| Order codes | Marking | Package | Packaging |
|-------------|---------|--------------------|---------------|
| STB30N65M5 | 30N65M5 | D ² PAK | Tape and reel |
| STF30N65M5 | 30N65M5 | TO-220FP | Tube |
| STI30N65M5 | 30N65M5 | I ² PAK | Tube |
| STP30N65M5 | 30N65M5 | TO-220 | Tube |
| STW30N65M5 | 30N65M5 | TO-247 | Tube |

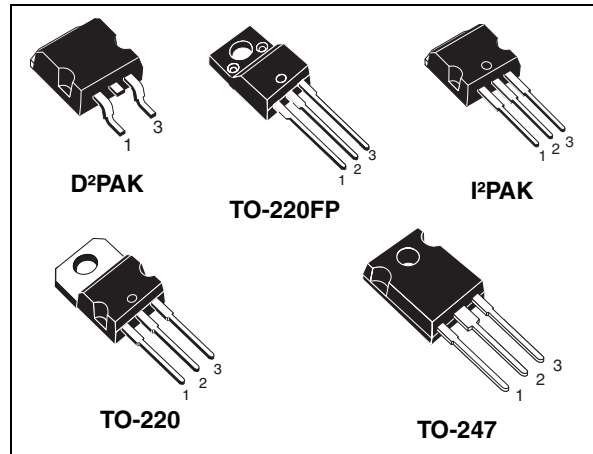
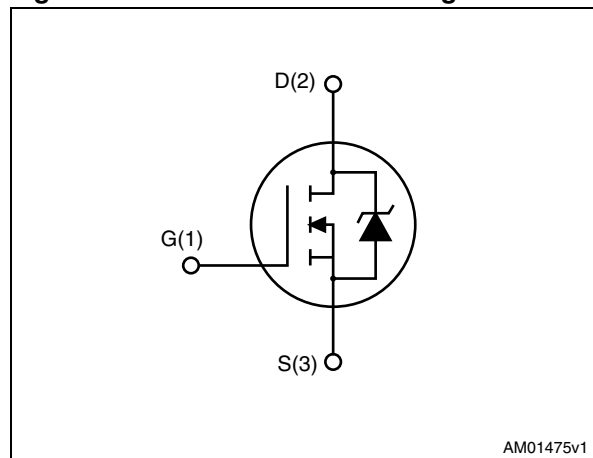

Figure 1. Internal schematic diagram



AM01475v1

Contents

| | | |
|----------|---|-----------|
| 1 | Electrical ratings | 3 |
| 2 | Electrical characteristics | 4 |
| 2.1 | Electrical characteristics (curves) | 6 |
| 3 | Test circuits | 9 |
| 4 | Package mechanical data | 10 |
| 5 | Packaging mechanical data | 19 |
| 6 | Revision history | 21 |

1 Electrical ratings

Table 2. Absolute maximum ratings

| Symbol | Parameter | Value | | Unit |
|--------------------------------|--|--|-------------------|------|
| | | TO-220, D ² PAK TO-247, I ² PAK | TO-220FP | |
| V _{GS} | Gate-source voltage | ± 25 | | V |
| I _D | Drain current (continuous) at T _C = 25 °C | 22 | 22 ⁽¹⁾ | A |
| I _D | Drain current (continuous) at T _C = 100 °C | 13 | 13 ⁽¹⁾ | A |
| I _{DM} ⁽²⁾ | Drain current (pulsed) | 88 | 88 ⁽¹⁾ | A |
| P _{TOT} | Total dissipation at T _C = 25 °C | 140 | 30 | W |
| I _{AR} | Max current during repetitive or single pulse avalanche (pulse width limited by T _{JMAX}) | 7 | | A |
| E _{AS} | Single pulse avalanche energy (starting T _j = 25°C, I _D = I _{AR} , V _{DD} = 50V) | 500 | | mJ |
| dv/dt ⁽³⁾ | Peak diode recovery voltage slope | 15 | | V/ns |
| V _{ISO} | Insulation withstand voltage (RMS) from all three leads to external heat sink (t=1 s; T _C =25 °C) | 2500 | | V |
| T _{stg} | Storage temperature | - 55 to 150 | | °C |
| T _j | Max. operating junction temperature | 150 | | °C |

- Limited only by maximum temperature allowed
- Pulse width limited by safe operating area
- I_{SD} ≤ 21 A, di/dt = 400 A/μs, V_{Peak} < V_{(BR)DSS}

Table 3. Thermal data

| Symbol | Parameter | Value | | | | | Unit |
|-----------------------|--|--------------------|----------|--------------------|--------|--------|------|
| | | D ² PAK | TO-220FP | I ² PAK | TO-220 | TO-247 | |
| R _{thj-case} | Thermal resistance junction-case max | 0.83 | 3.6 | 0.83 | | | °C/W |
| R _{thj-amb} | Thermal resistance junction-ambient max | | 62.5 | | | 50 | °C/W |
| R _{thj-pcb} | Thermal resistance junction-pcb max | 30 | | | | | °C/W |
| T _l | Maximum lead temperature for soldering purpose | 300 | | | | | °C |

2 Electrical characteristics

($T_C = 25\text{ °C}$ unless otherwise specified)

Table 4. On /off states

| Symbol | Parameter | Test conditions | Min. | Typ. | Max. | Unit |
|---------------|--|---|------|-------|----------|--------------------------------|
| $V_{(BR)DSS}$ | Drain-source breakdown voltage ($V_{GS} = 0$) | $I_D = 1\text{ mA}$ | 650 | | | V |
| I_{DSS} | Zero gate voltage drain current ($V_{GS} = 0$) | $V_{DS} = 650\text{ V}$ $V_{DS} = 650\text{ V}, T_C = 125\text{ °C}$ | | | 1 100 | μA μA |
| I_{GSS} | Gate-body leakage current ($V_{DS} = 0$) | $V_{GS} = \pm 25\text{ V}$ | | | 100 | nA |
| $V_{GS(th)}$ | Gate threshold voltage | $V_{DS} = V_{GS}, I_D = 250\text{ }\mu\text{A}$ | 3 | 4 | 5 | V |
| $R_{DS(on)}$ | Static drain-source on resistance | $V_{GS} = 10\text{ V}, I_D = 11\text{ A}$ | | 0.125 | 0.139 | Ω |

Table 5. Dynamic

| Symbol | Parameter | Test conditions | Min. | Typ. | Max. | Unit |
|-------------------|---------------------------------------|---|------|------|------|----------|
| C_{iss} | Input capacitance | $V_{DS} = 100\text{ V}, f = 1\text{ MHz},$ $V_{GS} = 0$ | - | 2880 | - | pF |
| C_{oss} | Output capacitance | | | 68 | | pF |
| C_{rss} | Reverse transfer capacitance | | | 5 | | pF |
| $C_{o(tr)}^{(1)}$ | Equivalent capacitance time related | $V_{GS} = 0, V_{DS} = 0\text{ to }520\text{ V}$ | - | 190 | - | pF |
| $C_{o(er)}^{(2)}$ | Equivalent capacitance energy related | $V_{GS} = 0, V_{DS} = 0\text{ to }520\text{ V}$ | - | 65 | - | pF |
| R_G | Intrinsic gate resistance | $f = 1\text{ MHz open drain}$ | - | 1.6 | - | Ω |
| Q_g | Total gate charge | $V_{DD} = 520\text{ V}, I_D = 11\text{ A},$ $V_{GS} = 10\text{ V}$ (see Figure 20) | - | 64 | - | nC |
| Q_{gs} | Gate-source charge | | | 16 | | nC |
| Q_{gd} | Gate-drain charge | | | 25 | | nC |

- $C_{oss\text{ eq.}}$ time related is defined as a constant equivalent capacitance giving the same charging time as C_{oss} when V_{DS} increases from 0 to 80% V_{DSS}
- $C_{oss\text{ eq.}}$ energy related is defined as a constant equivalent capacitance giving the same stored energy as C_{oss} when V_{DS} increases from 0 to 80% V_{DSS}

Table 6. Switching times

| Symbol | Parameter | Test conditions | Min. | Typ. | Max | Unit |
|--------------|---------------------|---|------|------|-----|------|
| $t_{d(off)}$ | Turn-off delay time | $V_{DD} = 400\text{ V}$, $I_D = 14\text{ A}$, $R_G = 4.7\ \Omega$, $V_{GS} = 10\text{ V}$ (see Figure 21) | | 50 | | ns |
| t_r | Rise time | | - | 8 | - | ns |
| t_c | Cross time | | 20 | | | ns |
| t_f | Fall time | | 10 | | | ns |

Table 7. Source drain diode

| Symbol | Parameter | Test conditions | Min. | Typ. | Max. | Unit |
|-----------------|-------------------------------|---|------|------|------|---------------|
| I_{SD} | Source-drain current | | - | | 22 | A |
| $I_{SDM}^{(1)}$ | Source-drain current (pulsed) | | | | 88 | A |
| $V_{SD}^{(2)}$ | Forward on voltage | $I_{SD} = 22\text{ A}$, $V_{GS} = 0$ | - | | 1.5 | V |
| t_{rr} | Reverse recovery time | $I_{SD} = 22\text{ A}$, $di/dt = 100\text{ A}/\mu\text{s}$ $V_{DD} = 60\text{ V}$ (see Figure 21) | - | 336 | | ns |
| Q_{rr} | Reverse recovery charge | | | 6 | | μC |
| I_{RRM} | Reverse recovery current | | | 32 | | A |
| t_{rr} | Reverse recovery time | $I_{SD} = 22\text{ A}$, $di/dt = 100\text{ A}/\mu\text{s}$ $V_{DD} = 60\text{ V}$, $T_J = 150\text{ }^\circ\text{C}$ (see Figure 21) | - | 395 | | ns |
| Q_{rr} | Reverse recovery charge | | | 7 | | μC |
| I_{RRM} | Reverse recovery current | | | 34 | | A |

1. Pulse width limited by safe operating area
2. Pulsed: Pulse duration = 300 μs , duty cycle 1.5%

2.1 Electrical characteristics (curves)

Figure 2. Safe operating area for TO-220, D²PAK, I²PAK

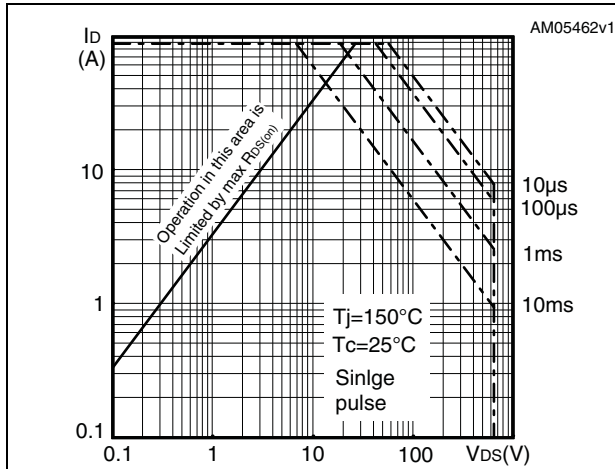

Figure 3. Thermal impedance for TO-220, D²PAK, I²PAK

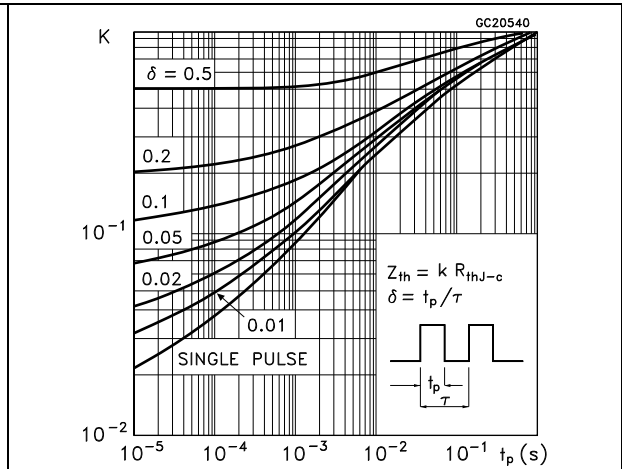

Figure 4. Safe operating area for TO-220FP

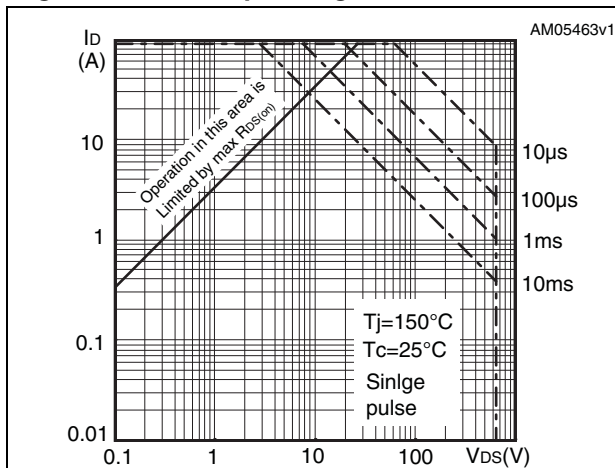

Figure 5. Thermal impedance for TO-220FP

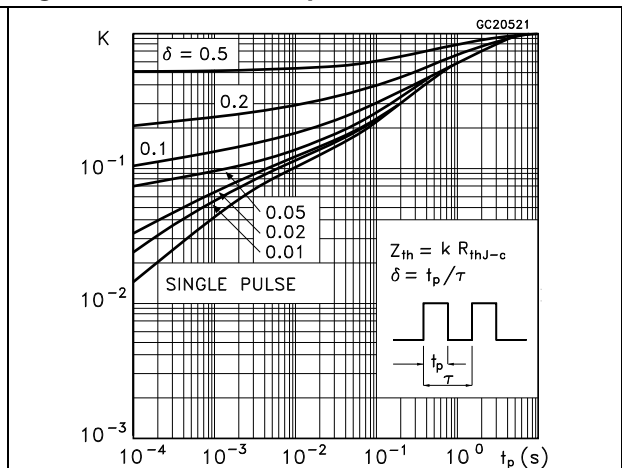

Figure 6. Safe operating area for TO-247

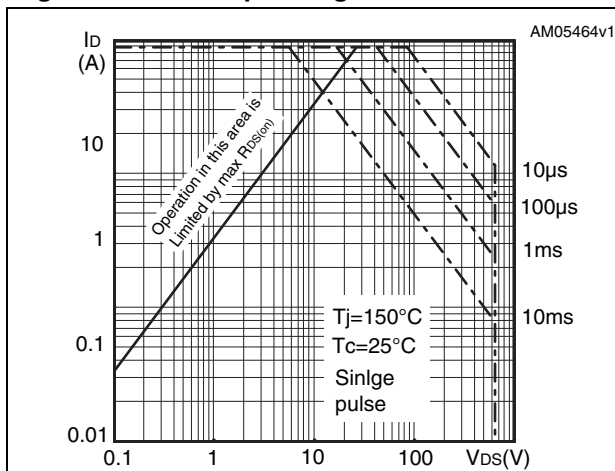

Figure 7. Thermal impedance for TO-247

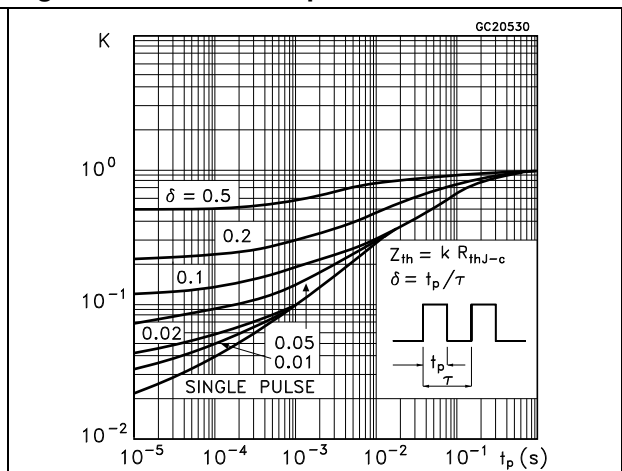

Figure 8. Output characteristics

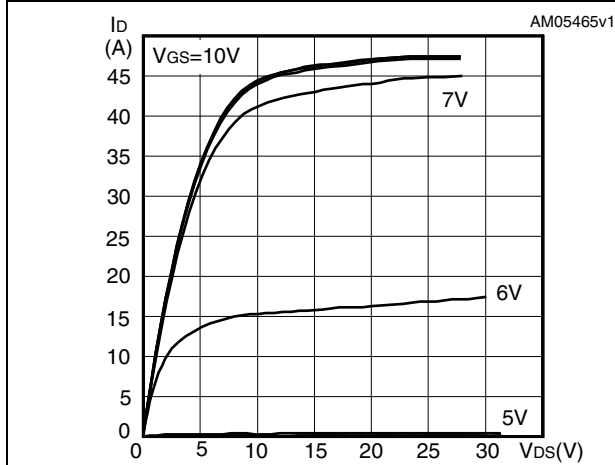

Figure 9. Transfer characteristics

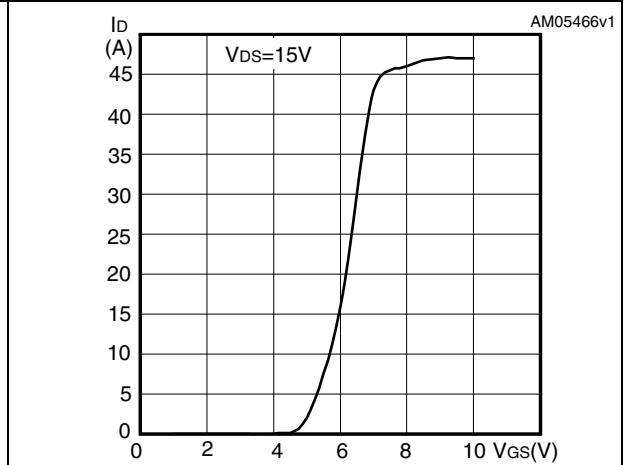

Figure 10. Gate charge vs gate-source voltage

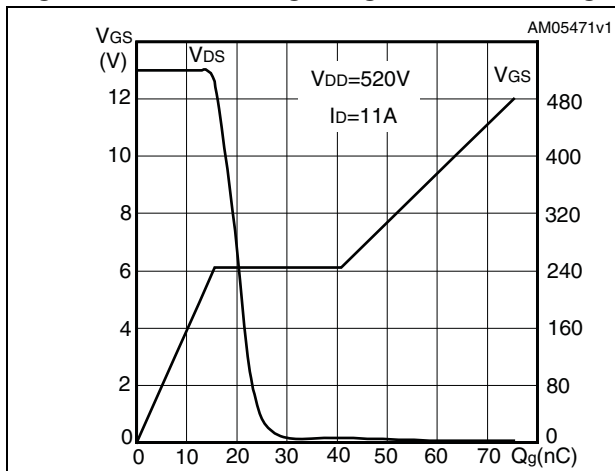

Figure 11. Static drain-source on resistance

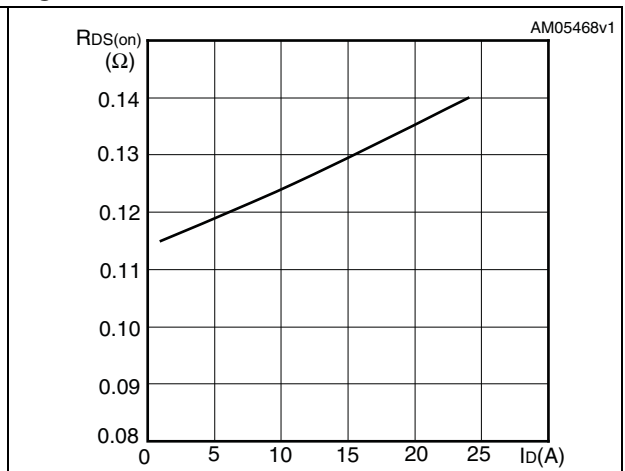

Figure 12. Capacitance variations

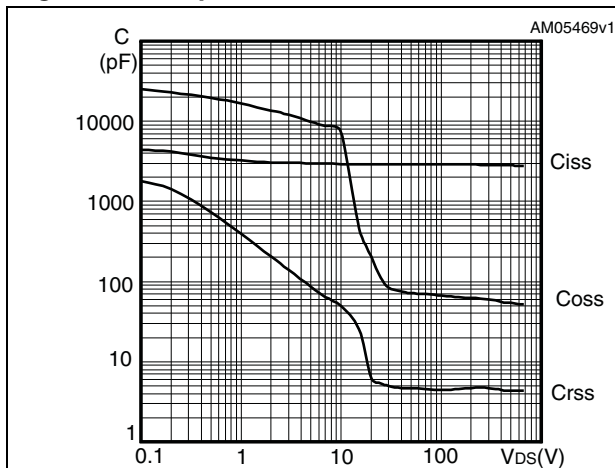

Figure 13. Output capacitance stored energy

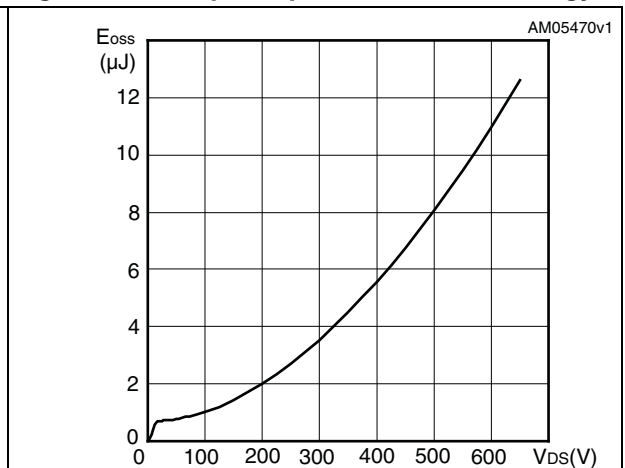

Figure 14. Normalized gate threshold voltage vs temperature

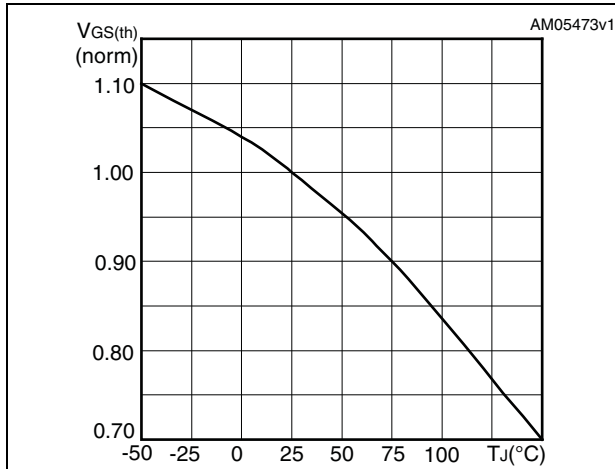

Figure 15. Normalized on resistance vs temperature

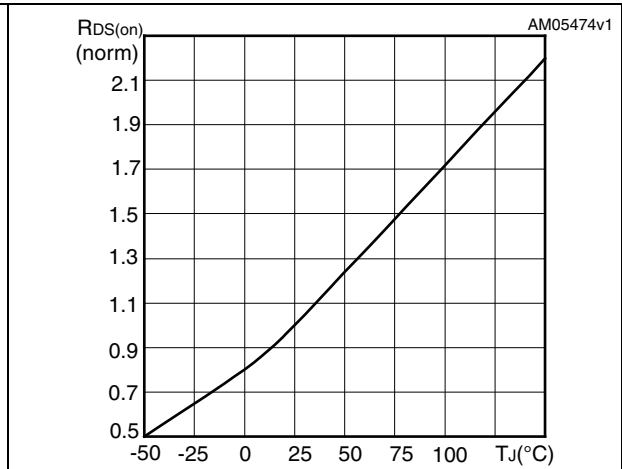

Figure 16. Source-drain diode forward characteristics

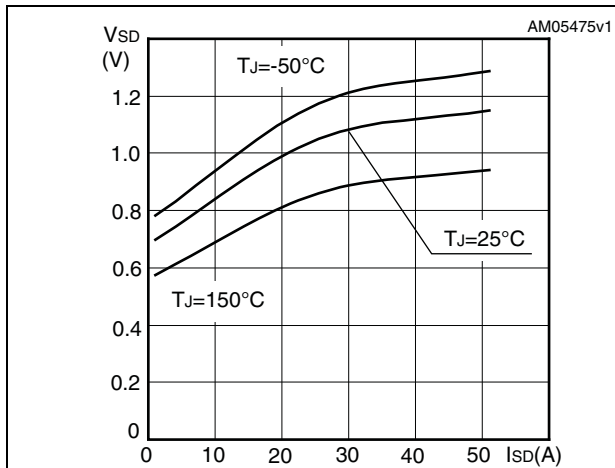

Figure 17. Normalized BV_{DSS} vs temperature

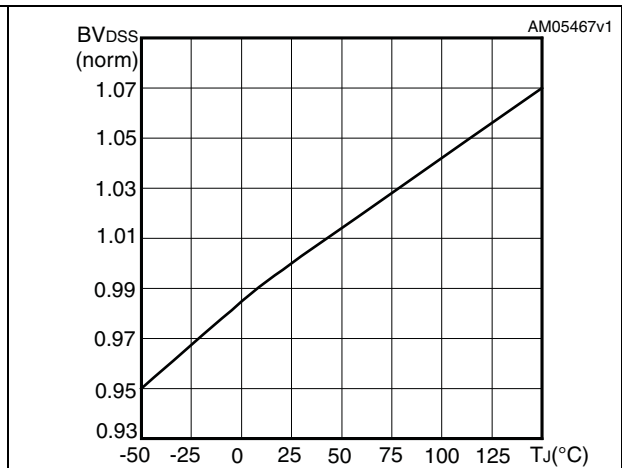
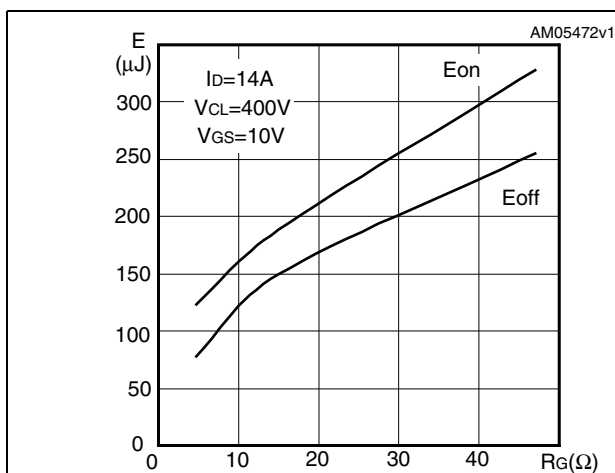

Figure 18. Switching losses vs gate resistance (1)



1. Eon including reverse recovery of a SiC diode

3 Test circuits

Figure 19. Switching times test circuit for resistive load

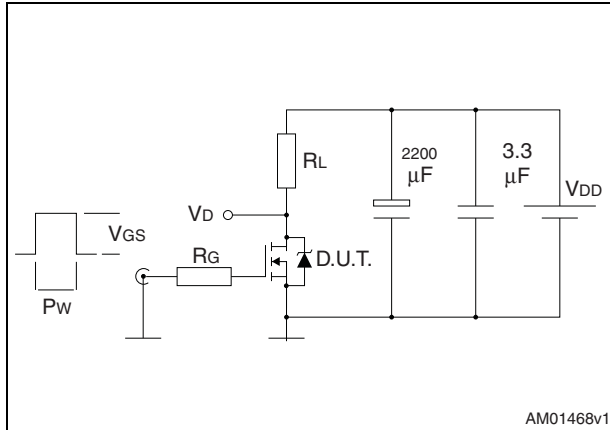

Figure 20. Gate charge test circuit

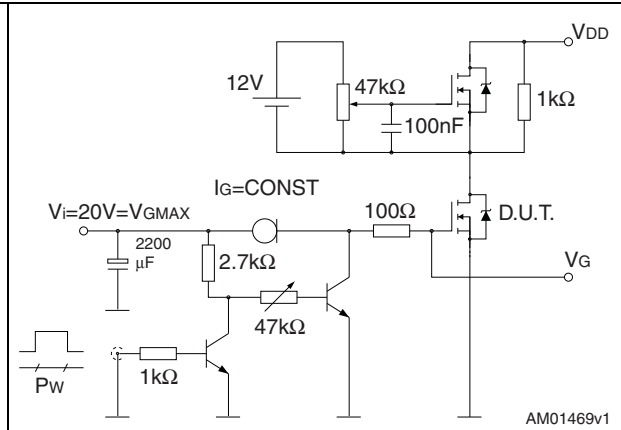

Figure 21. Test circuit for inductive load switching and diode recovery times

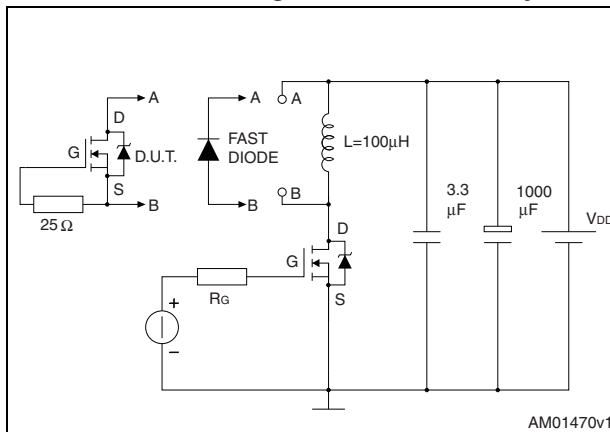

Figure 22. Unclamped inductive load test circuit

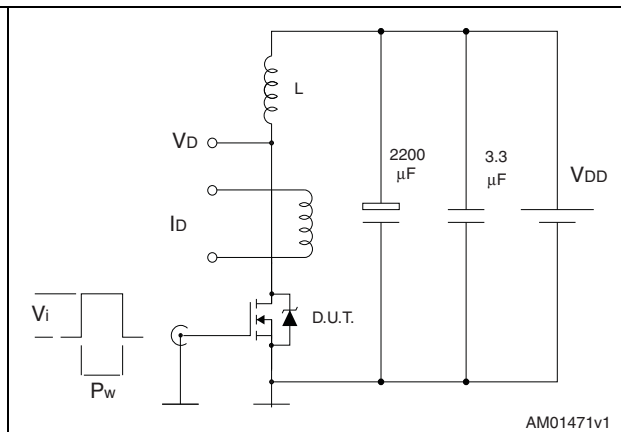

Figure 23. Unclamped inductive waveform

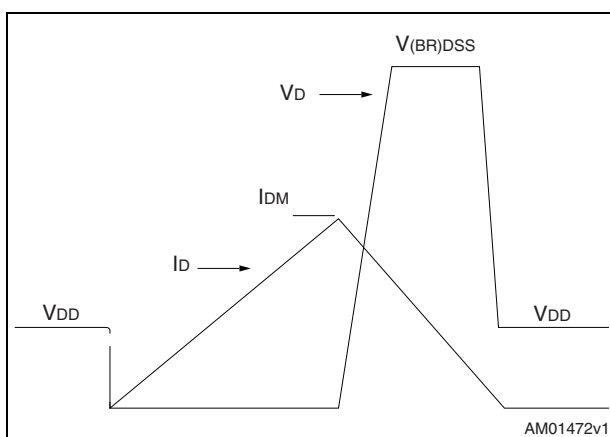
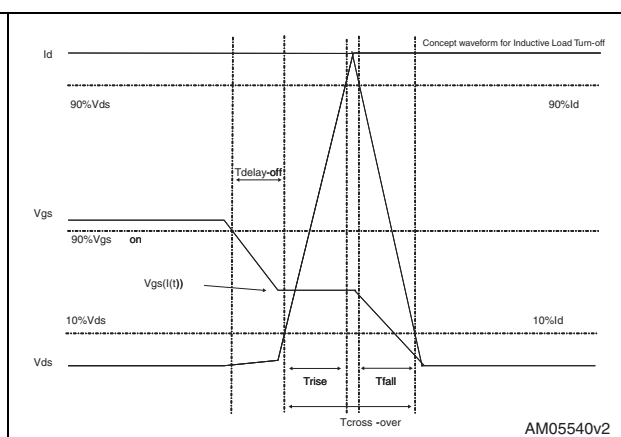

Figure 24. Switching time waveform



4 Package mechanical data

In order to meet environmental requirements, ST offers these devices in different grades of ECOPACK[®] packages, depending on their level of environmental compliance. ECOPACK[®] specifications, grade definitions and product status are available at: www.st.com. ECOPACKm is an ST trademark.

Table 8. D²PAK (TO-263) mechanical data

| Dim. | mm | | |
|------|------|------|-------|
| | Min. | Typ. | Max. |
| A | 4.40 | | 4.60 |
| A1 | 0.03 | | 0.23 |
| b | 0.70 | | 0.93 |
| b2 | 1.14 | | 1.70 |
| c | 0.45 | | 0.60 |
| c2 | 1.23 | | 1.36 |
| D | 8.95 | | 9.35 |
| D1 | 7.50 | | |
| E | 10 | | 10.40 |
| E1 | 8.50 | | |
| e | | 2.54 | |
| e1 | 4.88 | | 5.28 |
| H | 15 | | 15.85 |
| J1 | 2.49 | | 2.69 |
| L | 2.29 | | 2.79 |
| L1 | 1.27 | | 1.40 |
| L2 | 1.30 | | 1.75 |
| R | | 0.4 | |
| V2 | 0° | | 8° |

Figure 25. D²PAK (TO-263) drawing



Figure 26. D²PAK footprint^(a)



a. All dimensions are in millimeters

Table 9. TO-220FP mechanical data

| Dim. | mm | | |
|------|------|------|------|
| | Min. | Typ. | Max. |
| A | 4.4 | | 4.6 |
| B | 2.5 | | 2.7 |
| D | 2.5 | | 2.75 |
| E | 0.45 | | 0.7 |
| F | 0.75 | | 1 |
| F1 | 1.15 | | 1.70 |
| F2 | 1.15 | | 1.70 |
| G | 4.95 | | 5.2 |
| G1 | 2.4 | | 2.7 |
| H | 10 | | 10.4 |
| L2 | | 16 | |
| L3 | 28.6 | | 30.6 |
| L4 | 9.8 | | 10.6 |
| L5 | 2.9 | | 3.6 |
| L6 | 15.9 | | 16.4 |
| L7 | 9 | | 9.3 |
| Dia | 3 | | 3.2 |

Figure 27. TO-220FP drawing

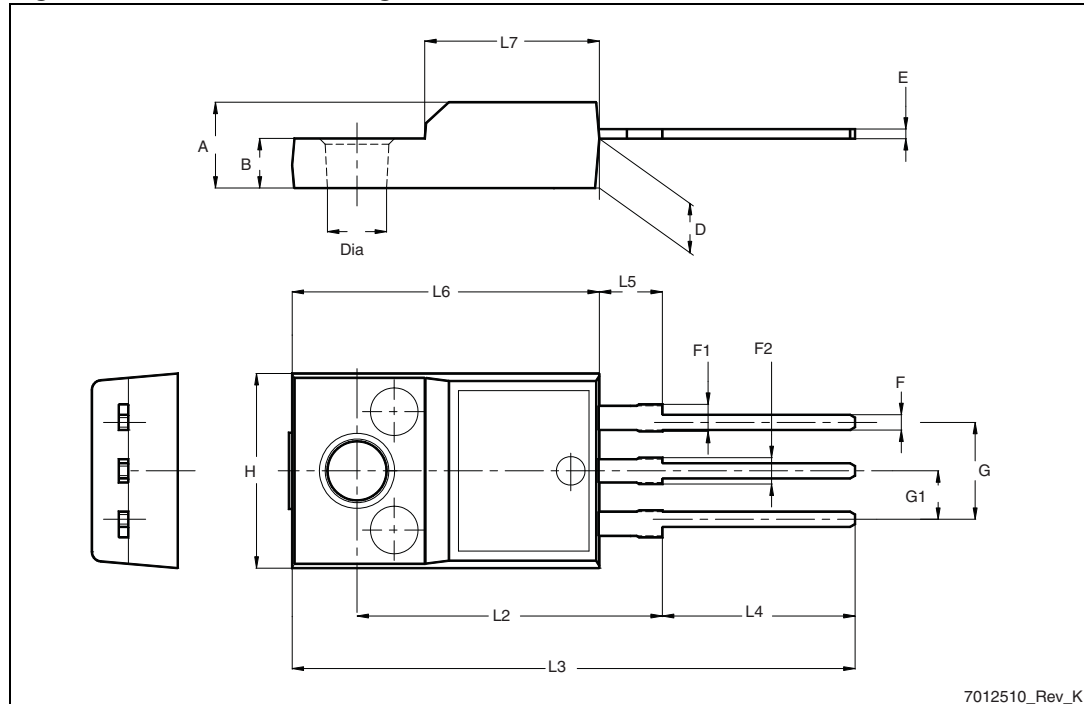
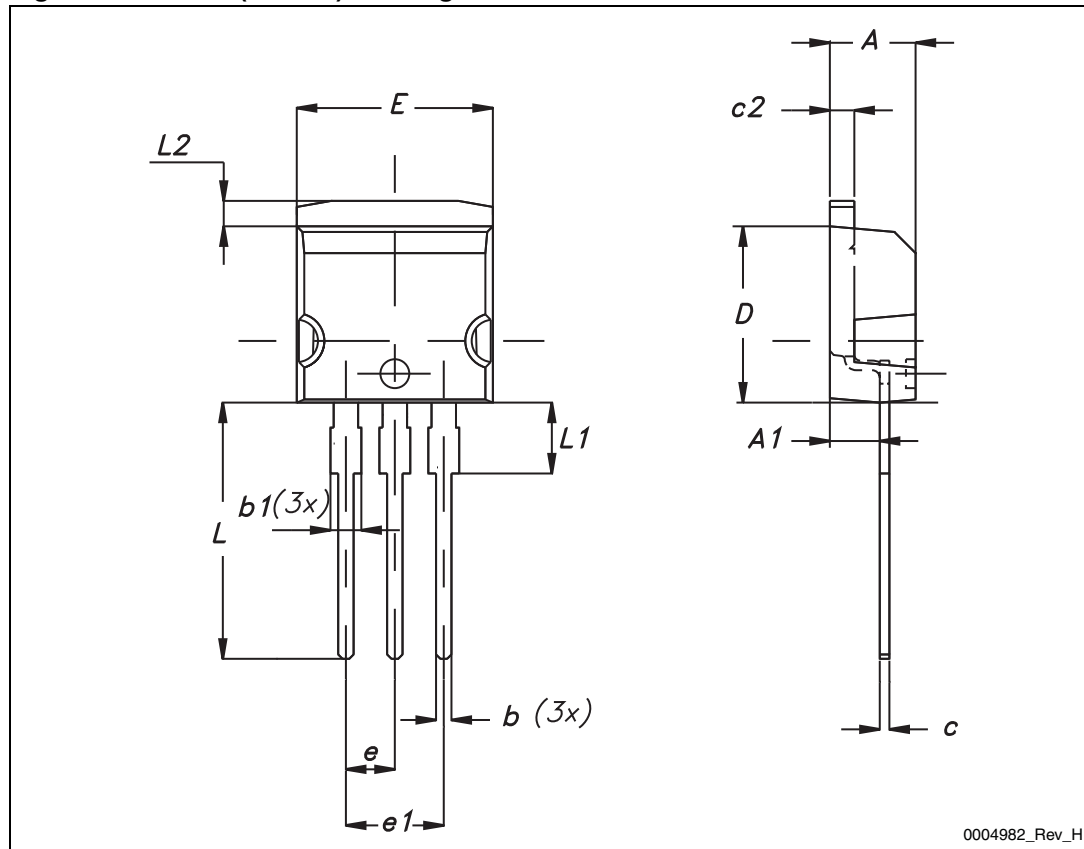

Table 10. I²PAK (TO-262) mechanical data

| DIM. | mm. | | |
|------|------|-----|-------|
| | min. | typ | max. |
| A | 4.40 | | 4.60 |
| A1 | 2.40 | | 2.72 |
| b | 0.61 | | 0.88 |
| b1 | 1.14 | | 1.70 |
| c | 0.49 | | 0.70 |
| c2 | 1.23 | | 1.32 |
| D | 8.95 | | 9.35 |
| e | 2.40 | | 2.70 |
| e1 | 4.95 | | 5.15 |
| E | 10 | | 10.40 |
| L | 13 | | 14 |
| L1 | 3.50 | | 3.93 |
| L2 | 1.27 | | 1.40 |

Figure 28. I²PAK (TO-262) drawing



0004982_Rev_H

Table 11. TO-220 type A mechanical data

| Dim. | mm | | |
|------|-------|-------|-------|
| | Min. | Typ. | Max. |
| A | 4.40 | | 4.60 |
| b | 0.61 | | 0.88 |
| b1 | 1.14 | | 1.70 |
| c | 0.48 | | 0.70 |
| D | 15.25 | | 15.75 |
| D1 | | 1.27 | |
| E | 10 | | 10.40 |
| e | 2.40 | | 2.70 |
| e1 | 4.95 | | 5.15 |
| F | 1.23 | | 1.32 |
| H1 | 6.20 | | 6.60 |
| J1 | 2.40 | | 2.72 |
| L | 13 | | 14 |
| L1 | 3.50 | | 3.93 |
| L20 | | 16.40 | |
| L30 | | 28.90 | |
| ØP | 3.75 | | 3.85 |
| Q | 2.65 | | 2.95 |

Figure 29. TO-220 type A drawing

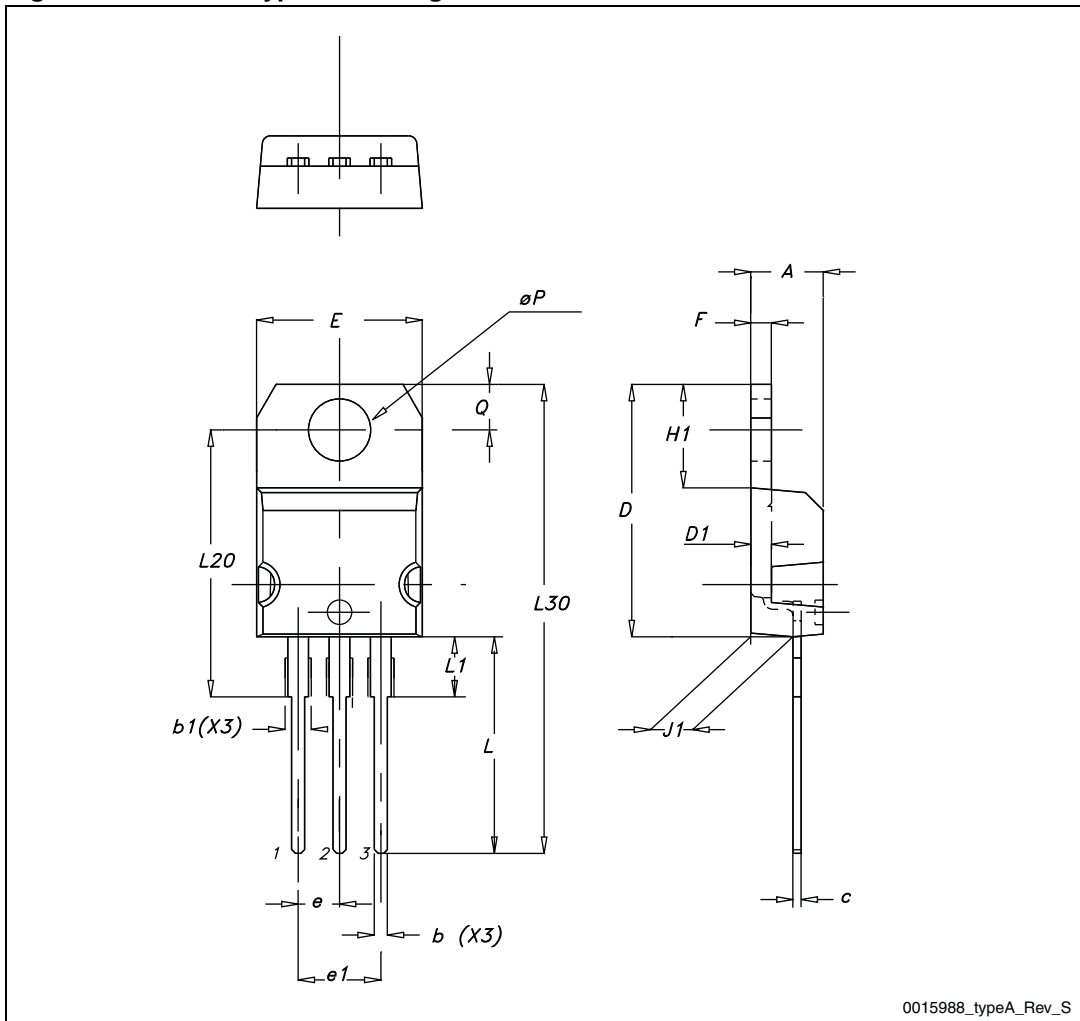

0015988_typeA_Rev_S

Table 12. TO-247 mechanical data

| Dim. | mm | | |
|------|-------|-------|-------|
| | Min. | Typ. | Max. |
| A | 4.85 | | 5.15 |
| A1 | 2.20 | | 2.60 |
| b | 1.0 | | 1.40 |
| b1 | 2.0 | | 2.40 |
| b2 | 3.0 | | 3.40 |
| c | 0.40 | | 0.80 |
| D | 19.85 | | 20.15 |
| E | 15.45 | | 15.75 |
| e | | 5.45 | |
| L | 14.20 | | 14.80 |
| L1 | 3.70 | | 4.30 |
| L2 | | 18.50 | |
| ØP | 3.55 | | 3.65 |
| ØR | 4.50 | | 5.50 |
| S | | 5.50 | |

Figure 30. TO-247 drawing

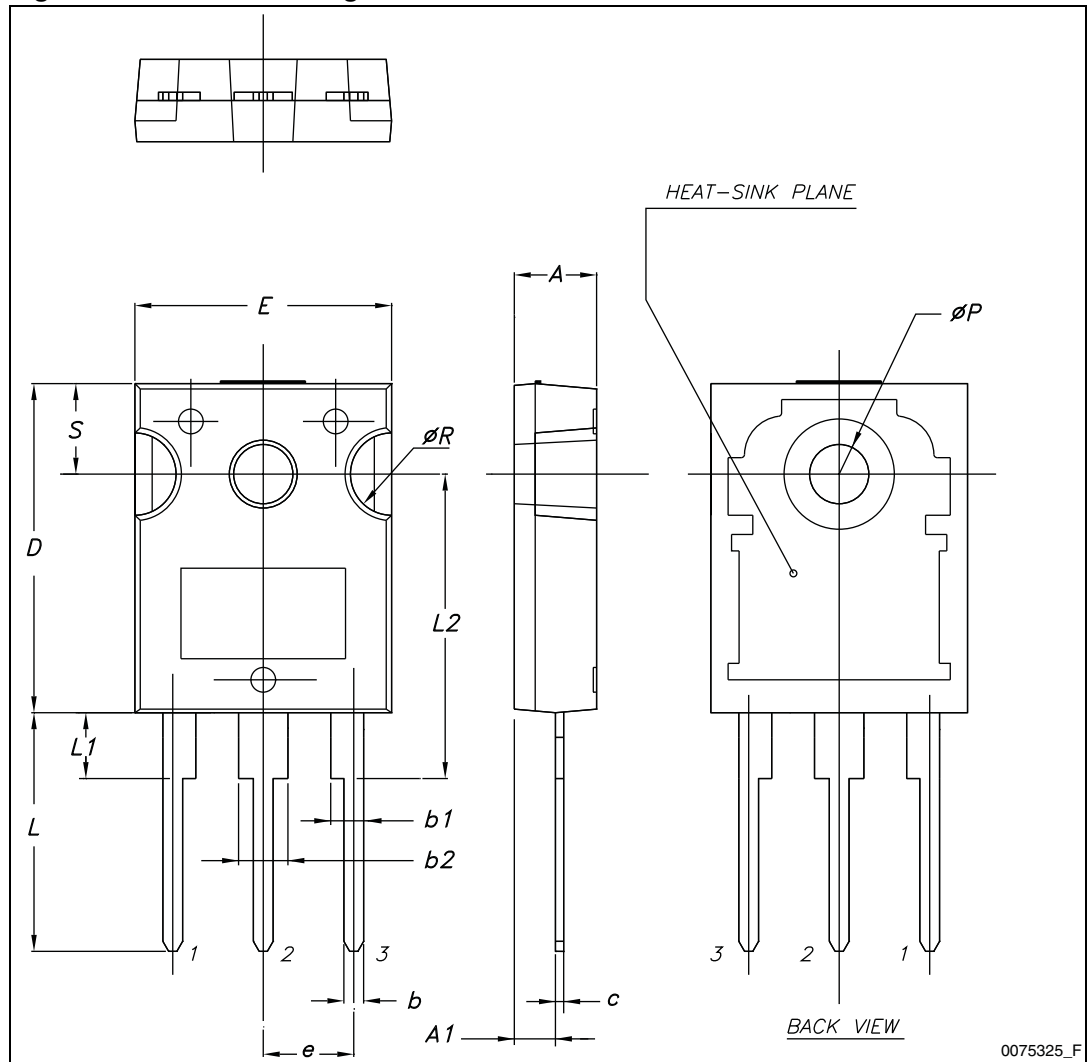

0075325_F

5 Packaging mechanical data

Table 13. D²PAK (TO-263) tape and reel mechanical data

| Tape | | | Reel | | |
|------|------|------|----------|------|------|
| Dim. | mm | | Dim. | mm | |
| | Min. | Max. | | Min. | Max. |
| A0 | 10.5 | 10.7 | A | | 330 |
| B0 | 15.7 | 15.9 | B | 1.5 | |
| D | 1.5 | 1.6 | C | 12.8 | 13.2 |
| D1 | 1.59 | 1.61 | D | 20.2 | |
| E | 1.65 | 1.85 | G | 24.4 | 26.4 |
| F | 11.4 | 11.6 | N | 100 | |
| K0 | 4.8 | 5.0 | T | | 30.4 |
| P0 | 3.9 | 4.1 | | | |
| P1 | 11.9 | 12.1 | Base qty | | 1000 |
| P2 | 1.9 | 2.1 | Bulk qty | | 1000 |
| R | 50 | | | | |
| T | 0.25 | 0.35 | | | |
| W | 23.7 | 24.3 | | | |

Figure 31. Tape



AM08852v2

Figure 32. Reel

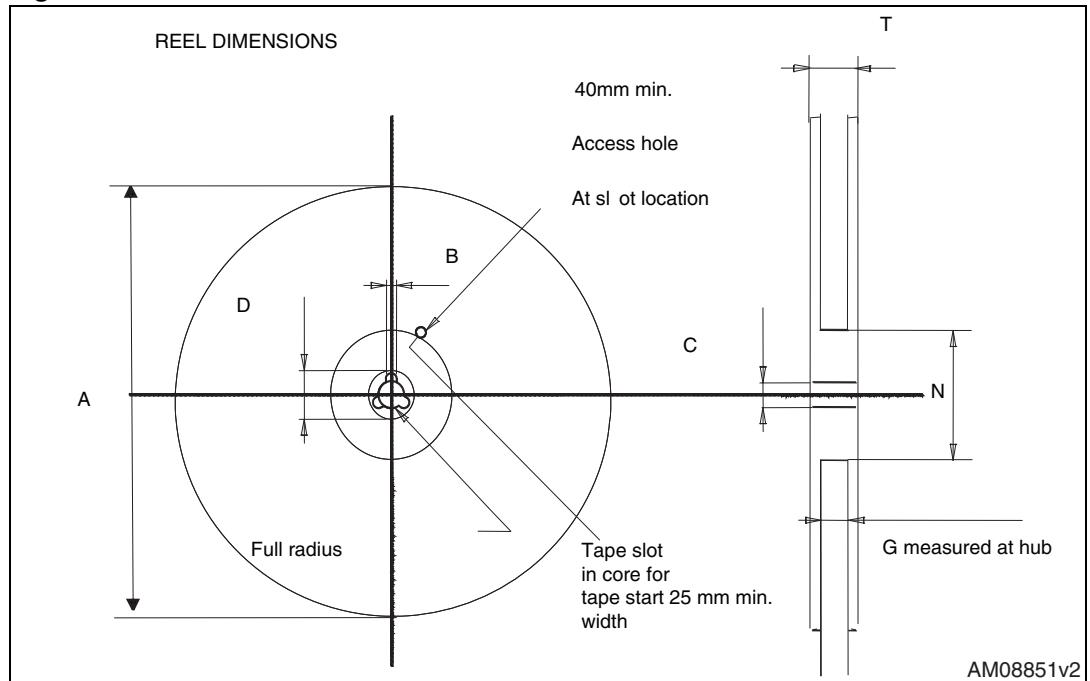

AM08851v2

6 Revision history

Table 14. Document revision history

| Date | Revision | Changes |
|-------------|----------|--|
| 16-Jan-2009 | 1 | First release |
| 21-Sep-2009 | 2 | Document status promoted from preliminary data to datasheet. |
| 22-Sep-2011 | 3 | <p>$C_{o(er)}$ and $C_{o(tr)}$ values changed in Table 5: Dynamic Table 6: Switching times parameters updates Figure 24: Switching time waveform has been corrected Minor text changes Section 4: Package mechanical data has been modified. Added:</p> <ul style="list-style-type: none"> – Table 8: D²PAK (TO-263) mechanical data, Figure 25: D²PAK (TO-263) drawing and Figure 26: D²PAK footprint; – Table 9: TO-220FP mechanical data, and Figure 27: TO-220FP drawing; – Table 10: I²PAK (TO-262) mechanical data, and Figure 28: I²PAK (TO-262) drawing; – Table 11: TO-220 type A mechanical data, and Figure 29: TO-220 type A drawing; – Table 12: TO-247 mechanical data, and Figure 30: TO-247 drawing; <p>Section 5: Packaging mechanical data has been modified. Added:</p> <ul style="list-style-type: none"> – Table 13: D²PAK (TO-263) tape and reel mechanical data, Figure 31: Tape and Figure 32: Reel; |

Please Read Carefully:

Information in this document is provided solely in connection with ST products. STMicroelectronics NV and its subsidiaries ("ST") reserve the right to make changes, corrections, modifications or improvements, to this document, and the products and services described herein at any time, without notice.

All ST products are sold pursuant to ST's terms and conditions of sale.

Purchasers are solely responsible for the choice, selection and use of the ST products and services described herein, and ST assumes no liability whatsoever relating to the choice, selection or use of the ST products and services described herein.

No license, express or implied, by estoppel or otherwise, to any intellectual property rights is granted under this document. If any part of this document refers to any third party products or services it shall not be deemed a license grant by ST for the use of such third party products or services, or any intellectual property contained therein or considered as a warranty covering the use in any manner whatsoever of such third party products or services or any intellectual property contained therein.

UNLESS OTHERWISE SET FORTH IN ST'S TERMS AND CONDITIONS OF SALE ST DISCLAIMS ANY EXPRESS OR IMPLIED WARRANTY WITH RESPECT TO THE USE AND/OR SALE OF ST PRODUCTS INCLUDING WITHOUT LIMITATION IMPLIED WARRANTIES OF MERCHANTABILITY, FITNESS FOR A PARTICULAR PURPOSE (AND THEIR EQUIVALENTS UNDER THE LAWS OF ANY JURISDICTION), OR INFRINGEMENT OF ANY PATENT, COPYRIGHT OR OTHER INTELLECTUAL PROPERTY RIGHT.

UNLESS EXPRESSLY APPROVED IN WRITING BY TWO AUTHORIZED ST REPRESENTATIVES, ST PRODUCTS ARE NOT RECOMMENDED, AUTHORIZED OR WARRANTED FOR USE IN MILITARY, AIR CRAFT, SPACE, LIFE SAVING, OR LIFE SUSTAINING APPLICATIONS, NOR IN PRODUCTS OR SYSTEMS WHERE FAILURE OR MALFUNCTION MAY RESULT IN PERSONAL INJURY, DEATH, OR SEVERE PROPERTY OR ENVIRONMENTAL DAMAGE. ST PRODUCTS WHICH ARE NOT SPECIFIED AS "AUTOMOTIVE GRADE" MAY ONLY BE USED IN AUTOMOTIVE APPLICATIONS AT USER'S OWN RISK.

Resale of ST products with provisions different from the statements and/or technical features set forth in this document shall immediately void any warranty granted by ST for the ST product or service described herein and shall not create or extend in any manner whatsoever, any liability of ST.

ST and the ST logo are trademarks or registered trademarks of ST in various countries.

Information in this document supersedes and replaces all information previously supplied.

The ST logo is a registered trademark of STMicroelectronics. All other names are the property of their respective owners.

© 2011 STMicroelectronics - All rights reserved

STMicroelectronics group of companies

Australia - Belgium - Brazil - Canada - China - Czech Republic - Finland - France - Germany - Hong Kong - India - Israel - Italy - Japan - Malaysia - Malta - Morocco - Philippines - Singapore - Spain - Sweden - Switzerland - United Kingdom - United States of America

www.st.com