



# KA7500C SMPS Controller

## Features

- Internal Regulator Provides a Stable 5V Reference Supply Trimmed to  $\pm 1\%$  Accuracy
- Uncommitted Output TR for 200mA Sink or Source Current
- Output Control for Push-Pull or Single-Ended Operation
- Variable Duty Cycle by Dead-Time Control (Pin 4) Complete PWM Control Circuit
- On-Chip Oscillator with Master or Slave Operation
- Internal Circuit Prohibits Double Pulse at Either Output

## Description

The KA7500C is used for the control circuit of the pulse-width modulation switching regulator. The KA7500C consists of 5V reference voltage circuit, two error amplifiers, flip flop, an output control circuit, a PWM comparator, a dead-time comparator, and an oscillator.

This device can be operated in the switching frequency of 1kHz to 300kHz. The precision of voltage reference ( $V_{REF}$ ) is improved up to  $\pm 1\%$  with trimming. This provides a better output voltage regulation. The operating temperature range is  $-25^{\circ}\text{C} \sim +85^{\circ}\text{C}$ .

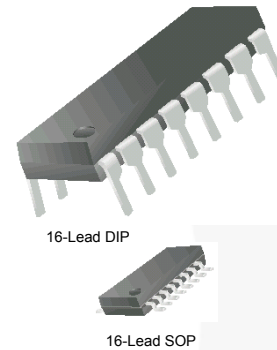

## Ordering Information

Part Number	Operating Temperature Range	 Eco Status	Package	Packing Method
KA7500C	-25 to +85°C	RoHS	16-Lead Dual Inline Package (DIP)	Tube
KA7500CD			16-Lead Small Outline Package (SOP)	Tube
KA7500CDTF				Tape and Reel

 For Fairchild's definition of Eco Status, please visit: [http://www.fairchildsemi.com/company/green/rohs\\_green.html](http://www.fairchildsemi.com/company/green/rohs_green.html).

Block Diagram

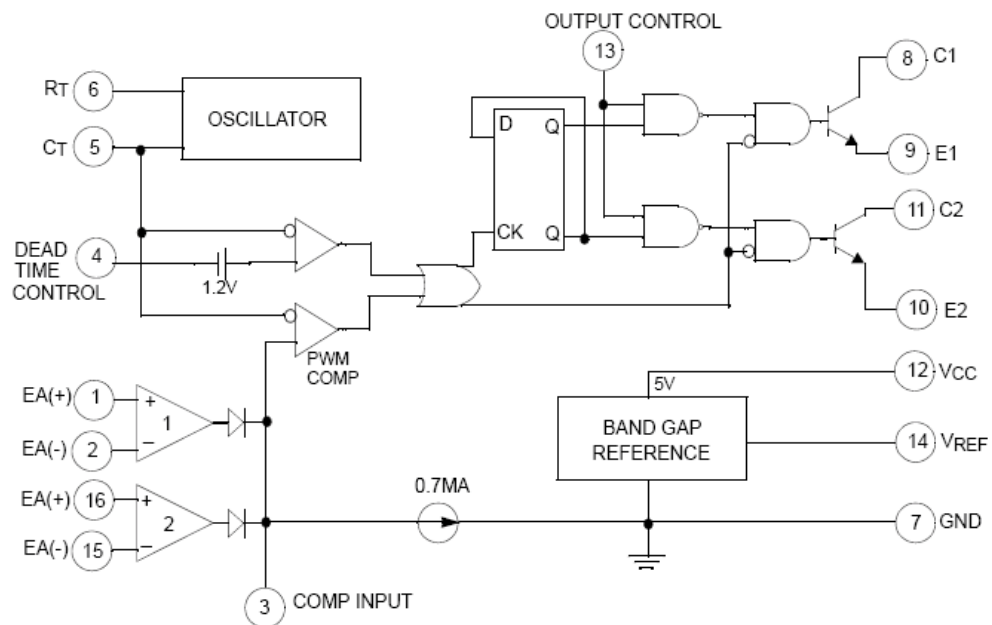

Figure 1. Block Diagram

Typical Application

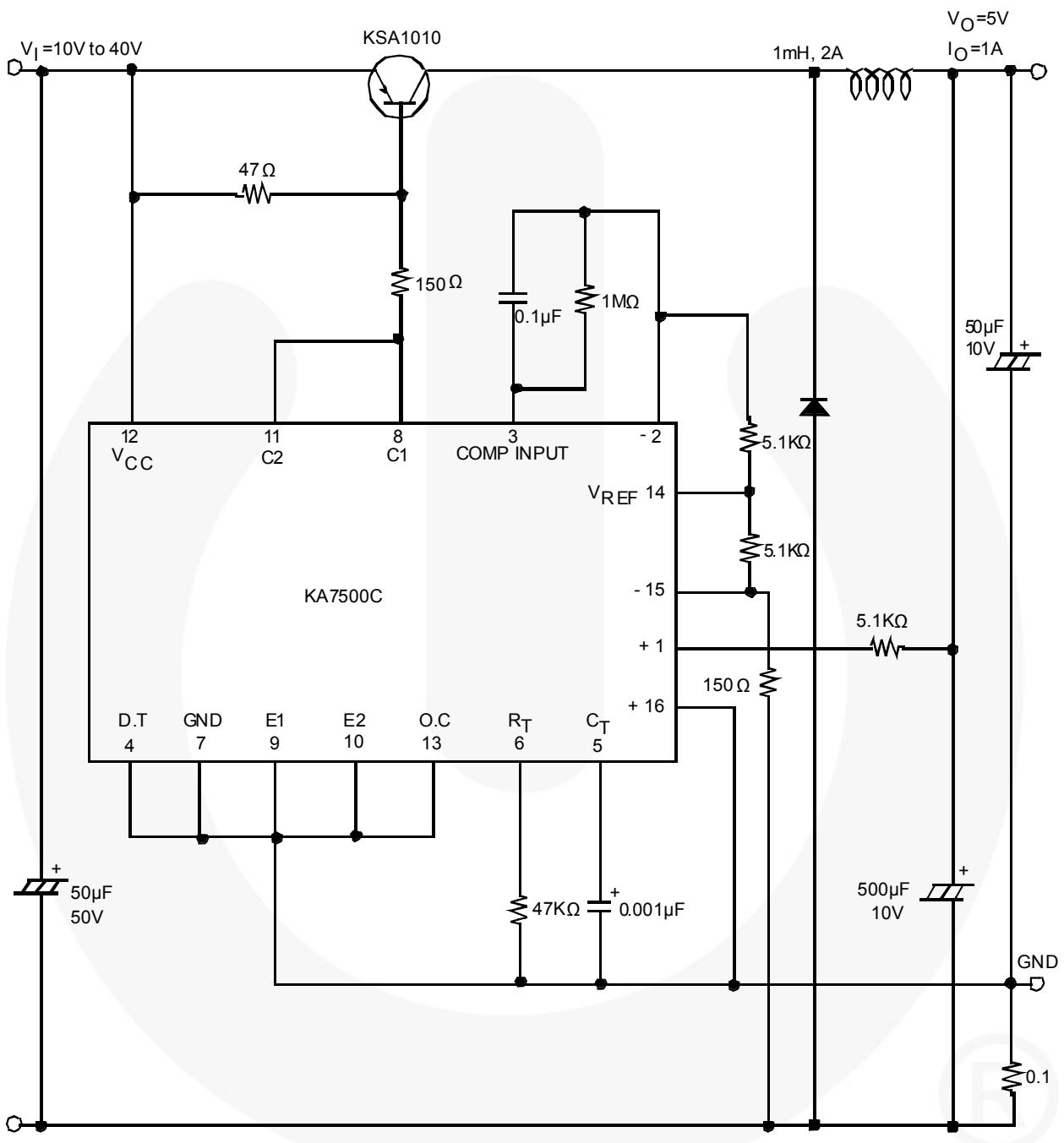

Figure 2. Pulse-Width Modulated Step-Down Converter

## Absolute Maximum Ratings

Stresses exceeding the absolute maximum ratings may damage the device. The device may not function or be operable above the recommended operating conditions and stressing the parts to these levels is not recommended. In addition, extended exposure to stresses above the recommended operating conditions may affect device reliability. The absolute maximum ratings are stress ratings only.

Symbol	Parameter	Min.	Max.	Unit
$V_{CC}$	Supply Voltage		42	V
$V_C$	Collector Supply Voltage		42	V
$I_O$	Output Current		250	mA
$V_{IN}$	Amplifier Input Voltage		$V_{CC} + 0.3$	V
$P_D$	Power Dissipation	KA7500C	1	W
		KA7500CD	0.9	
$T_{OPR}$	Operation Temperature Range	-25	+85	°C
$T_{STG}$	Storage Temperature Rang	-65	+150	°C
$T_J$	Junction Temperature		+125	°C

## Recommended Operating Conditions

The Recommended Operating Conditions table defines the conditions for actual device operation. Recommended operating conditions are specified to ensure optimal performance to the datasheet specifications. Fairchild does not recommend exceeding them or designing to Absolute Maximum Ratings.

Symbol	Parameter	Min.	Typ.	Max.	Unit
$V_{CC}$	Power Supply Voltage	7	15	40	V
$V_{C1}, V_{C2}$	Collector Supply Voltage		30	40	V
$I_{C1}, I_{C2}$	Collector Output Current (Each Transition)			200	mA
$V_{IN}$	Amplifier Input Voltage	0.3		$V_{CC} - 2.0$	V
$I_{FB}$	Current Into Feedback Terminal			0.3	mA
$I_{REF}$	Reference Output Terminal			10	mA
$R_T$	Timing Resistor	1.8	30.0	500.0	K $\Omega$
$C_T$	Timing Capacitor	0.0047	0.0010	10.0000	$\mu$ A
$f_{OSC}$	Oscillator Frequency	1	40	200	kHz
$V_{IN\_PWM}$	PWM Input Voltage (Pins 3, 4, and 13)	0.3		5.3	V

## Electrical Characteristics

$V_{CC} = 20V$ ,  $f = 10kHz$ ,  $T_A = -25^{\circ}C$  to  $+85^{\circ}C$ , unless otherwise specified.

Symbol	Parameter	Conditions	Min.	Typ.	Max.	Units
<b>Reference Section</b>						
$V_{REF}$	Reference Output Voltage	$I_{REF}=1mA$ , $T_A=25^{\circ}C^{(1)}$	4.95	5.00	5.05	V
		$I_{REF}=1mA$	4.90	5.00	5.10	
$R_{LINE}$	Line Regulation	$V_{CC}=7V$ to $40V$		2	25	mV
$R_{LOAD}$	Load Regulation	$I_{REF}=1mA$ to $10mA$		1	15	mV
$I_{SC}$	Short-Circuit Output Current	$V_{REF}=0V$	10	35	50	mA
<b>Oscillation Frequency</b>						
$f_{OSC}$	Oscillation Frequency	$C_T=0.001\mu F$ , $R_T=30K\Omega$		40.0		kHz
		$C_T=0.01\mu F$ , $R_T=12K\Omega$ , $T_A=25^{\circ}C$	9.2	10.0	10.8	
		$C_T=0.01\mu F$ , $R_T=12K\Omega$ , $T_A=T_{LOW}$ to $T_{HIGH}$	9.0		12.0	
$\Delta f/\Delta t$	Frequency Change with Temperature	$C_T=0.01\mu F$ , $R_T=12K\Omega$			2	%
<b>Dead-Time Control Section</b>						
$I_{BIAS}$	Input Bias Current	$V_{CC}=15V$ , $0V \leq V_4 \leq 5.25V$		-2	-10	$\mu A$
$D_{(MAX)}$	Maximum Duty Cycle	$V_{CC}=15V$ , $V_4=0V$ , OC $Pin=V_{REF}$	45			%
$V_{ITH}$	Input Threshold Voltage	Zero Duty Cycle		3.0	3.3	V
		Maximum Duty Cycle	0			
<b>Error Amplifier Section</b>						
$V_{IO}$	Input Offset Voltage	$V_3=2.5V$		2	10	mV
$I_{IO}$	Input Offset Current	$V_3=2.5V$		25	250	mA
$I_{BIAS}$	Input Bias Current	$V_3=2.5V$		0.2	1.0	$\mu A$
$V_{CIM}$	Common Mode Input Voltage	$7V \leq V_{CC} \leq 40V$	-0.3		$V_{CC}$	V
$G_{VO}$	Open-Loop Voltage Gain	$0.5V \leq V_3 \leq 3.5V$	70	95		dB
$B_W$	Unit-Gain Bandwidth			650		kHz
<b>PWM Comparator Section</b>						
$V_{ITH}$	Input Threshold Voltage	Zero Duty Cycle		4.0	4.5	V
$I_{SINK}$	Input Sink Current	$V_3=0.7V$	-0.3	-0.7		mA
<b>Output Section</b>						
$V_{CE(SAT)}$	Output Saturation Voltage Common Emitter	$V_E=0V$ , $I_C=200mA$		1.0	1.3	V
$V_{CC(SAT)}$	Emitter-Follower	$V_C=15V$ , $I_E=-200mA$		1.5	2.5	
$I_{C(OFF)}$	Collector Off-State Current	$V_{CC}=40V$ , $V_{CE}=40V$		2	100	$\mu A$
$I_{E(OFF)}$	Emitter Off-State Current	$V_{CC}=V_C=40V$ , $V_E=40V$			-100	
<b>Total Device</b>						
$I_{CC}$	Supply Current	$Pin6=V_{REF}$ , $V_{CC}=15V$		6	10	mA
<b>Output Switching Characteristics</b>						
$t_R$	Rise Time, Common Emitter, Common Collector			100	200	ns
$t_F$	Fall Time, Common Emitter, Common Collector			25	100	

### Note:

- This is guaranteed where the marking code of the package surface is over 027.

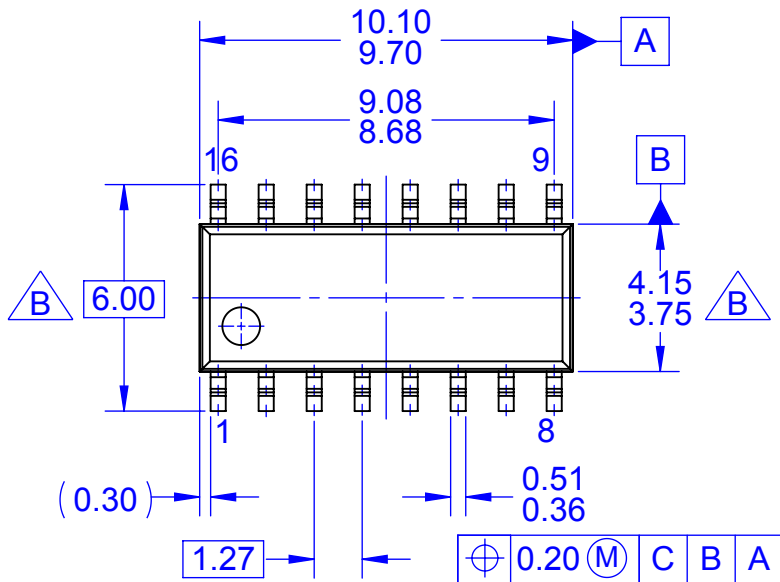

TOP VIEW

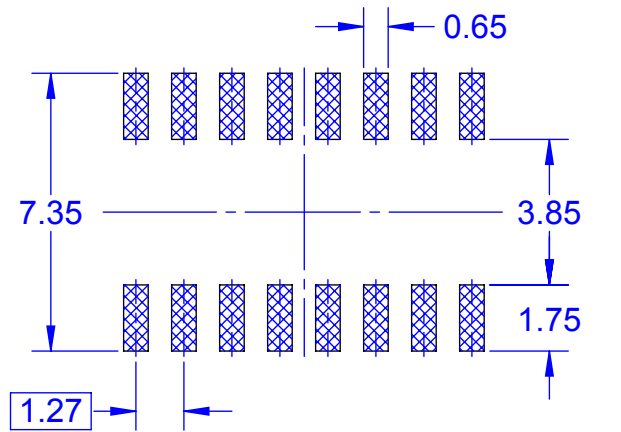

LAND PATTERN RECOMMENDATION

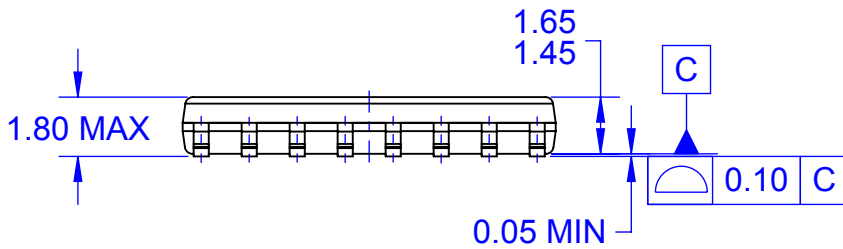

FRONT VIEW

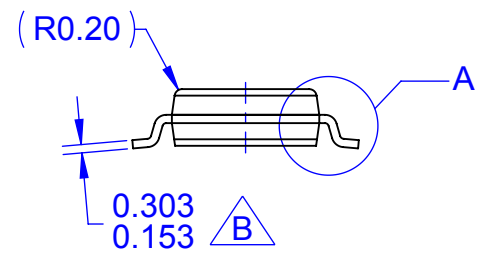

SIDE VIEW

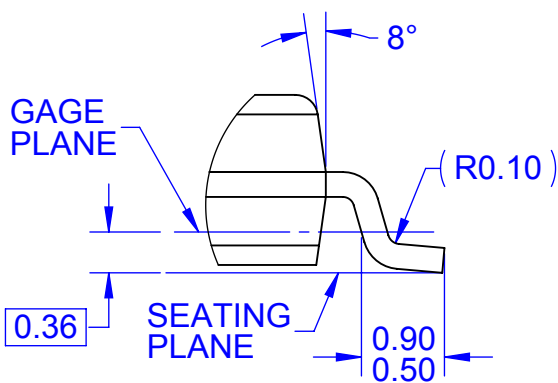

DETAIL A  
SCALE 3:1

NOTES:

A. THIS DRAWING COMPLIES WITH JEDEC MS-012, EXCEPT AS NOTED

B. THIS DIMENSION IS OUTSIDE JEDEC MS-012 VALUE

C. ALL DIMENSIONS ARE IN MILLIMETERS  
D. DIMENSIONS ARE EXCLUSIVE OF BURRS, MOLD FLASH, AND TIE BAR EXTRUSIONS

E. LAND PATTERN STANDARD:  
SOIC127P600X175-16AM

F. DRAWING FILENAME: MKT-M16Erev2



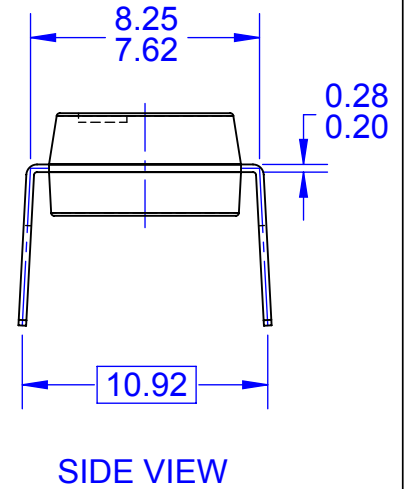
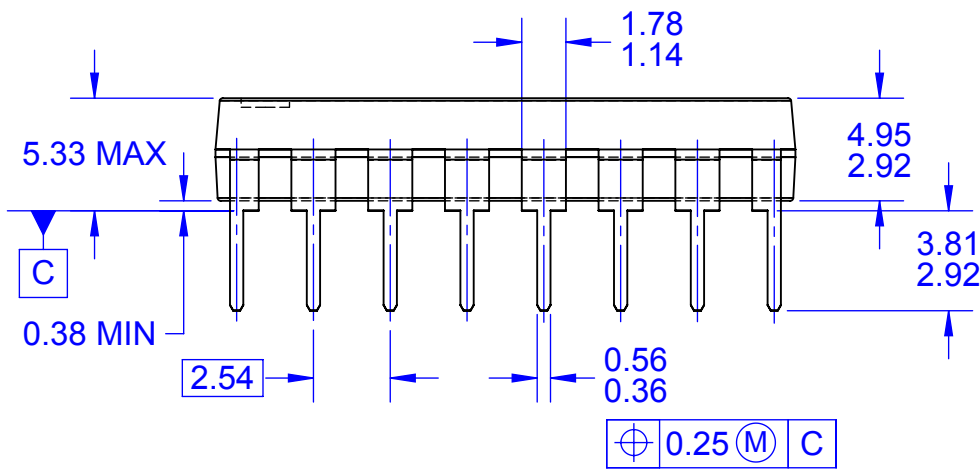
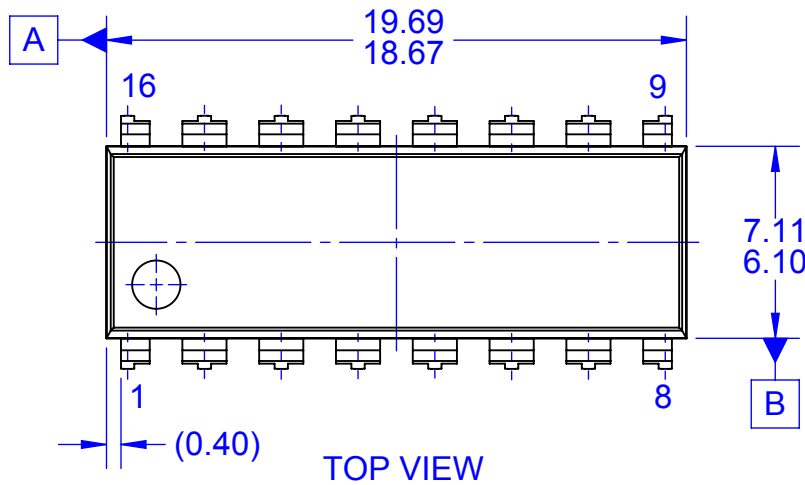

NOTES:

- A. CONFORMS TO JEDEC MS-001, VARIATION BB
- B. ALL DIMENSIONS ARE IN MILLIMETERS
- C. DIMENSIONS ARE EXCLUSIVE OF BURRS, MOLD FLASH, AND TIE BAR PROTRUSIONS
- D. DIMENSIONS AND TOLERANCES PER ASME Y14.5M-2009
- E. DRAWING FILENAME: MKT-N16Erev3





**TRADEMARKS**

The following includes registered and unregistered trademarks and service marks, owned by Fairchild Semiconductor and/or its global subsidiaries, and is not intended to be an exhaustive list of all such trademarks.

AccuPower™  
AttitudeEngine™  
Awinda®  
AX-CAP®\*  
BitSiC™  
Build it Now™  
CorePLUS™  
CorePOWER™  
CROSSVOL™  
CTL™  
Current Transfer Logic™  
DEUXPEED®  
Dual Cool™  
EcoSPARK®  
EfficientMax™  
ESBC™  
F®  
Fairchild®  
Fairchild Semiconductor®  
FACT Quiet Series™  
FACT®  
FastvCore™  
FETBench™  
FPS™

F-PFS™  
FRFET®  
Global Power Resource™  
GreenBridge™  
Green FPS™  
Green FPS™ e-Series™  
Gmax™  
GTO™  
IntelliMAX™  
ISOPLANAR™  
Making Small Speakers Sound Louder and Better™  
MegaBuck™  
MICROCOUPLER™  
MicroFET™  
MicroPak™  
MicroPak2™  
MillerDrive™  
MotionMax™  
MotionGrid®  
MTi®  
MTx®  
MVN®  
mWSaver®  
OptoHiT™  
OPTOLOGIC®

OPTOPLANAR®  
Power Supply WebDesigner™  
PowerTrench®  
PowerXS™  
Programmable Active Droop™  
QFET®  
QS™  
Quiet Series™  
RapidConfigure™  
Saving our world, 1mW/W/kW at a time™  
SignalWise™  
SmartMax™  
SMART START™  
Solutions for Your Success™  
SPM®  
STEALTH™  
SuperFET®  
SuperSOT™-3  
SuperSOT™-6  
SuperSOT™-8  
SupreMOS®  
SyncFET™  
Sync-Lock™

SYSTEM GENERAL®  
TinyBoost®  
TinyBuck®  
TinyCalc™  
TinyLogic®  
TINYOPTO™  
TinyPower™  
TinyPWM™  
TinyWire™  
TranSiC™  
TriFault Detect™  
TRUECURRENT®\*  
µSerDes™  
SerDes®  
UHC®  
Ultra FRFET™  
UniFET™  
VCX™  
VisualMax™  
VoltagePlus™  
XS™  
Xsens™  
仙童®

\* Trademarks of System General Corporation, used under license by Fairchild Semiconductor.

**DISCLAIMER**

FAIRCHILD SEMICONDUCTOR RESERVES THE RIGHT TO MAKE CHANGES WITHOUT FURTHER NOTICE TO ANY PRODUCTS HEREIN TO IMPROVE RELIABILITY, FUNCTION, OR DESIGN. TO OBTAIN THE LATEST, MOST UP-TO-DATE DATASHEET AND PRODUCT INFORMATION, VISIT OUR WEBSITE AT [HTTP://WWW.FAIRCHILDSEMI.COM](http://www.fairchildsemi.com). FAIRCHILD DOES NOT ASSUME ANY LIABILITY ARISING OUT OF THE APPLICATION OR USE OF ANY PRODUCT OR CIRCUIT DESCRIBED HEREIN; NEITHER DOES IT CONVEY ANY LICENSE UNDER ITS PATENT RIGHTS, NOR THE RIGHTS OF OTHERS. THESE SPECIFICATIONS DO NOT EXPAND THE TERMS OF FAIRCHILD'S WORLDWIDE TERMS AND CONDITIONS, SPECIFICALLY THE WARRANTY THEREIN, WHICH COVERS THESE PRODUCTS.

**AUTHORIZED USE**

Unless otherwise specified in this data sheet, this product is a standard commercial product and is not intended for use in applications that require extraordinary levels of quality and reliability. This product may not be used in the following applications, unless specifically approved in writing by a Fairchild officer: (1) automotive or other transportation, (2) military/aerospace, (3) any safety critical application – including life critical medical equipment – where the failure of the Fairchild product reasonably would be expected to result in personal injury, death or property damage. Customer's use of this product is subject to agreement of this Authorized Use policy. In the event of an unauthorized use of Fairchild's product, Fairchild accepts no liability in the event of product failure. In other respects, this product shall be subject to Fairchild's Worldwide Terms and Conditions of Sale, unless a separate agreement has been signed by both Parties.

**ANTI-COUNTERFEITING POLICY**

Fairchild Semiconductor Corporation's Anti-Counterfeiting Policy. Fairchild's Anti-Counterfeiting Policy is also stated on our external website, [www.fairchildsemi.com](http://www.fairchildsemi.com), under Terms of Use

Counterfeiting of semiconductor parts is a growing problem in the industry. All manufacturers of semiconductor products are experiencing counterfeiting of their parts. Customers who inadvertently purchase counterfeit parts experience many problems such as loss of brand reputation, substandard performance, failed applications, and increased cost of production and manufacturing delays. Fairchild is taking strong measures to protect ourselves and our customers from the proliferation of counterfeit parts. Fairchild strongly encourages customers to purchase Fairchild parts either directly from Fairchild or from Authorized Fairchild Distributors who are listed by country on our web page cited above. Products customers buy either from Fairchild directly or from Authorized Fairchild Distributors are genuine parts, have full traceability, meet Fairchild's quality standards for handling and storage and provide access to Fairchild's full range of up-to-date technical and product information. Fairchild and our Authorized Distributors will stand behind all warranties and will appropriately address any warranty issues that may arise. Fairchild will not provide any warranty coverage or other assistance for parts bought from Unauthorized Sources. Fairchild is committed to combat this global problem and encourage our customers to do their part in stopping this practice by buying direct or from authorized distributors.

**PRODUCT STATUS DEFINITIONS**

**Definition of Terms**

Datasheet Identification	Product Status	Definition
Advance Information	Formative / In Design	Datasheet contains the design specifications for product development. Specifications may change in any manner without notice.
Preliminary	First Production	Datasheet contains preliminary data; supplementary data will be published at a later date. Fairchild Semiconductor reserves the right to make changes at any time without notice to improve design.
No Identification Needed	Full Production	Datasheet contains final specifications. Fairchild Semiconductor reserves the right to make changes at any time without notice to improve the design.
Obsolete	Not In Production	Datasheet contains specifications on a product that is discontinued by Fairchild Semiconductor. The datasheet is for reference information only.



# Mouser Electronics

Authorized Distributor

Click to View Pricing, Inventory, Delivery & Lifecycle Information:

[Fairchild Semiconductor:](#)

[KA7500CDTF](#) [KA7500C](#)