



SK1816

LINEAR INTEGRATED CIRCUIT

BIPOLAR LATCH TYPE HALL EFFECT FOR HIGH-TEMPERATURE OPERATION

DESCRIPTION

The UTC SK1816 is a semiconductor integrated circuit utilizing the Hall effect. It designed to operate in the alternating magnetic field especially at low supply voltage and operation over extended temperature ranges to +125°C.

This Hall IC is suitable for application to various kinds of sensors, contact-less switches, such as Speed sensor, Position sensor, Rotation sensor, Contact-less sensor, and Motor control.

FEATURES

- * Wide supply voltage range of 2.5V to 20V
- * Wide temperature operation range of -20°C ~ +125°C
- * Alternating magnetic field operation
- * Built-in protection diode
- * TTL and MOS IC are directly drivable by the output
- * The life is semipermanent because it employs contact-less parts
- * SIP-3 and SOT-23 package are available.

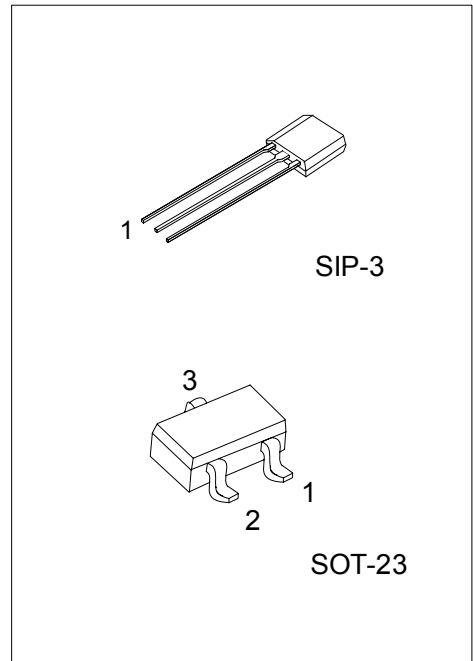

*Pb-free plating product number: SK1816L

ORDERING INFORMATION

Order Number		Package	Pin Assignment			Packing
Normal	Lead Free Plating		1	2	3	
SK1816-AE3-4-R	SK1816L-AE3-4-R	SOT-23	O	I	G	Tape Reel
SK1816-G03-D-K	SK1816L-G03-D-K	SIP-3	I	G	O	Bulk

Note: Pin Assignment: I:V_{SS} O:V_{OUT} G:GND

<p>SK1816L-AE3-4-R</p>	<p>(1) Packing Type (2) Pin Assignment (3) Package Type (4) Lead Plating</p>	<p>(1) K: Bulk, R: Tape Reel (2) refer to Pin Assignment (3) AE3: SOT-23, G03: SIP-3 (4) L: Lead Free Plating, Blank: Pb/Sn</p>
------------------------	--	---

MARKING INFORMATION

SIP-3

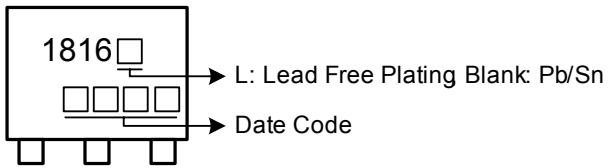

SOT-23

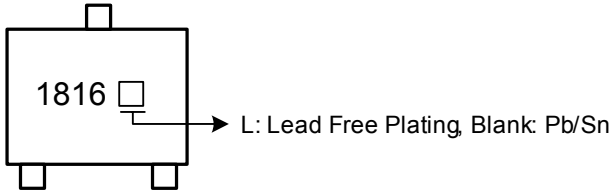

BLOCK DIAGRAM

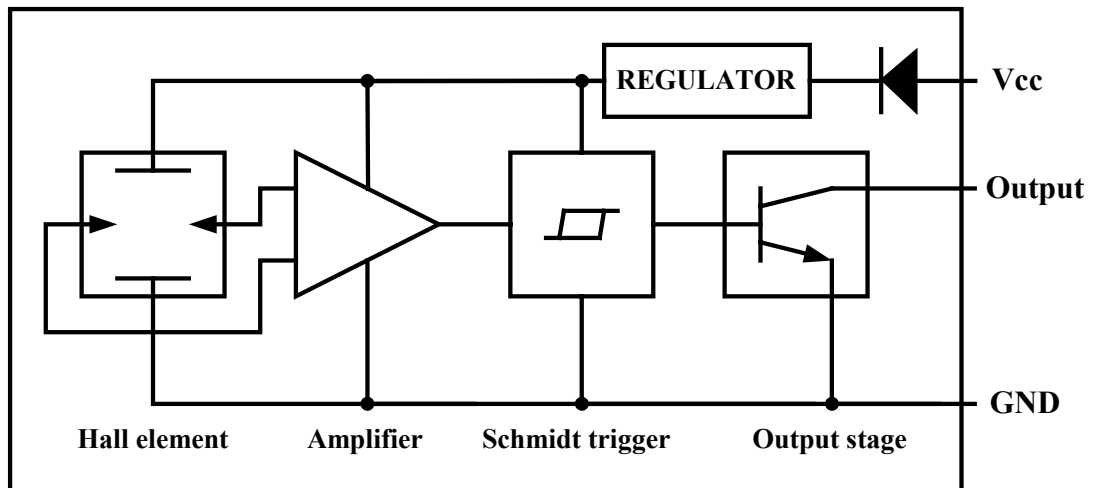

■ ABSOLUTE MAXIMUM RATINGS (Ta = 25°C)

PARAMETER	SYMBOL	RATINGS	UNIT
Supply Voltage	V _{CC}	2.5~20	V
Supply Current	I _{CC}	10	mA
Circuit Current	I _o	20	mA
Power Dissipation	SIP-3	400	mW
	SOT-23	200	
Operating Temperature	T _{OPR}	-20 ~ +125	°C
Storage Temperature	T _{STG}	-40 ~ +150	°C

Note 1. Absolute maximum ratings are those values beyond which the device could be permanently damaged. Absolute maximum ratings are stress ratings only and functional device operation is not implied.

2. The device is guaranteed to meet performance specification within 0°C~+70°C operating temperature range and assured by design from -20°C~+125°C.

■ ELECTRICAL CHARACTERISTICS (Ta=25°C, unless otherwise specified.)

PARAMETER	SYMBOL	TEST CONDITIONS	MIN	TYP	MAX	UNIT
Low-Level Output Voltage	V _{OL}	V _{CC} = 16V, I _{OUT} = 12mA, B = 30 mT			0.7	V
		V _{CC} = 3.6V, I _{OUT} = 12mA, B = 30 mT			0.7	V
Output Leakage Current	I _{LEAK}	V _{CC} = 16V, B = -30 mT		1	10	μA
Output Short Circuit Current	-I _{OS}	V _{CC} = 16V, V _{OUT} = 0V, B = -30 mT		0.8		mA
Supply Current	I _{CC}	V _{CC} = 16V			6	mA
		V _{CC} = 3.6V			5.5	mA
Output Switching Time	T _R	V _{CC} = 16V, R _L = 10KΩ, C _L = 10PF			5	μS
	T _F	V _{CC} = 16V, R _L = 10KΩ, C _L = 10PF			1	μS
MAGNETIC CHARACTERISTICS						
Operate Point	B _{OP}	At Ta = +25°C			5	mT
Release Point	B _{RP}	At Ta = +25°C			-5	mT
Hysteresis	B _{HYS}	At Ta = +25°C			5.5	mT

NOTE: 1. B_{OP} = operate point (output turns ON); B_{RP} = release point (output turns OFF); B_{HYS} = hysteresis (B_{OP} - B_{RP}).

As used here, negative flux densities are defined as less than zero (algebraic convention). Typical values are at Ta = +25°C and V_{CC} = 12V.

2. 1mT = 10 gauss

PACKAGE INFORMATION

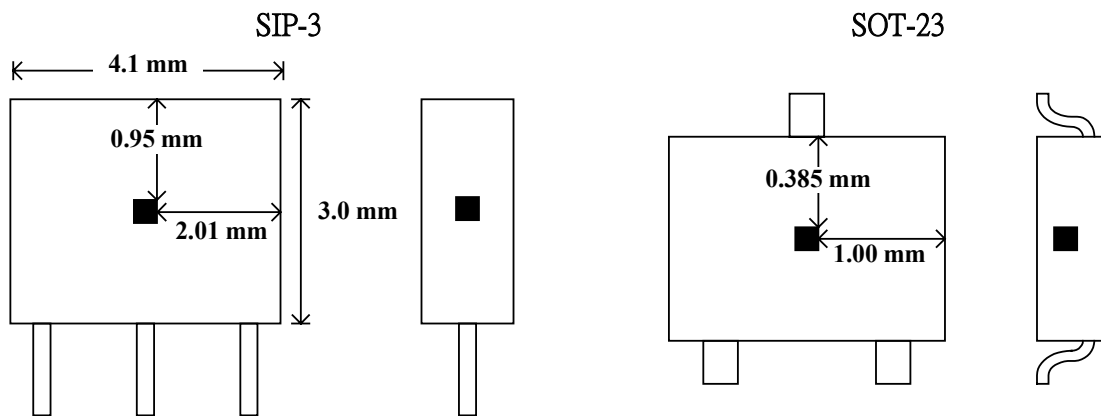

Fig. 1 SENSOR LOCATIONS

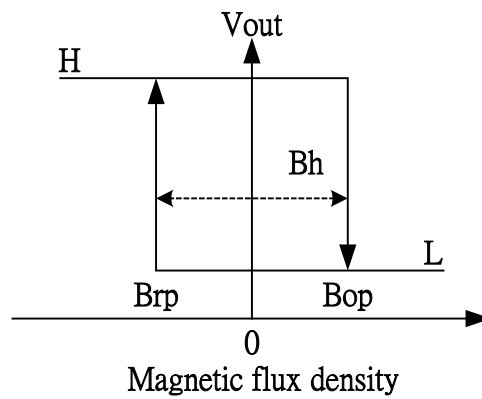
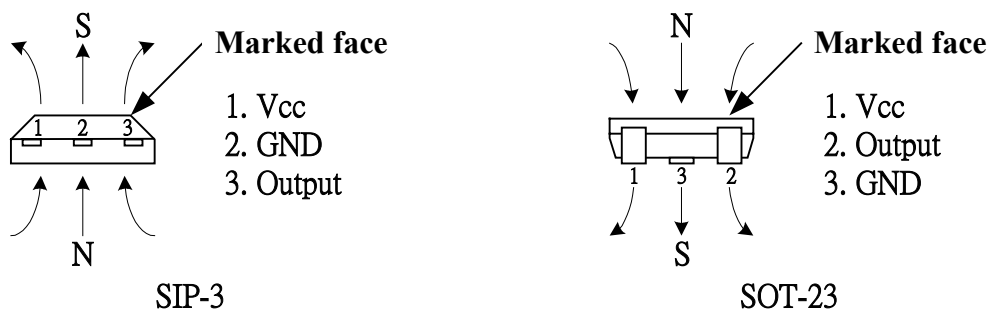
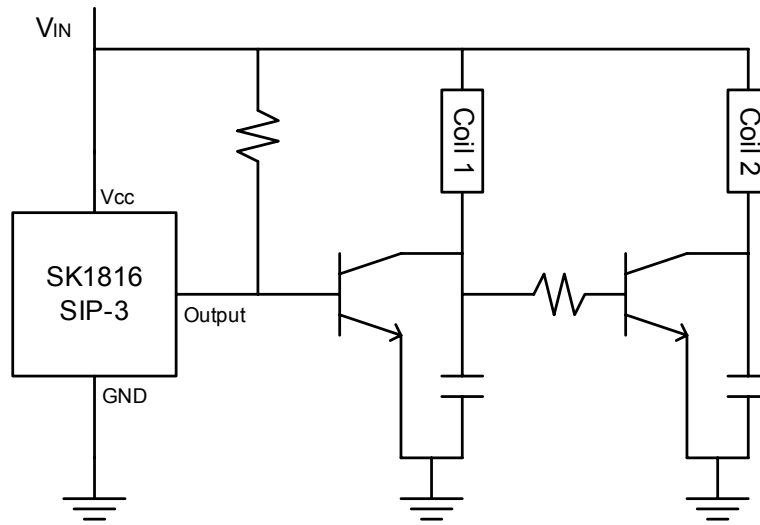
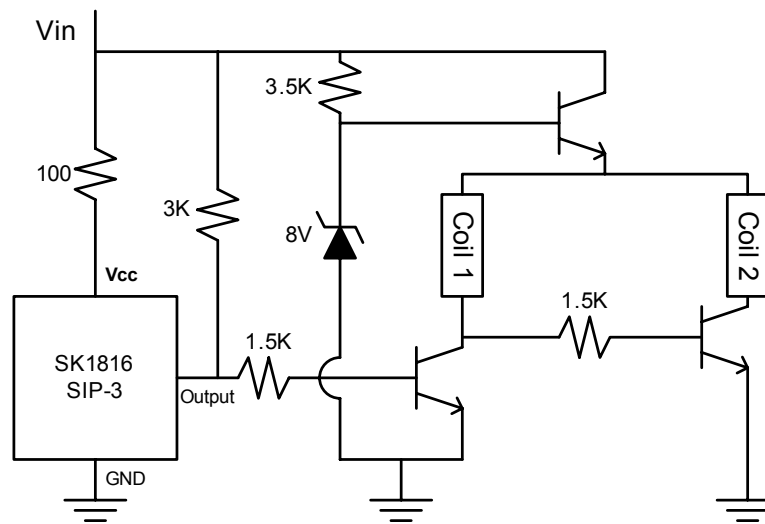

Fig.2 APPLYING DIRECTION OF MAGNETIC FLUX

■ TYPICAL APPLICATION CIRCUIT



FOR DC FAN 1



FOR DC FAN 2

■ TEST CIRCUIT

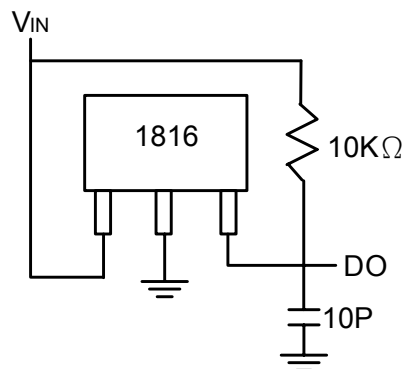

TYPICAL CHARACTERISTICS

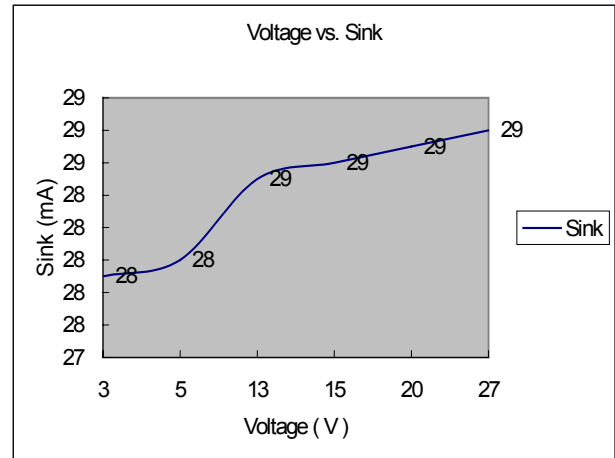
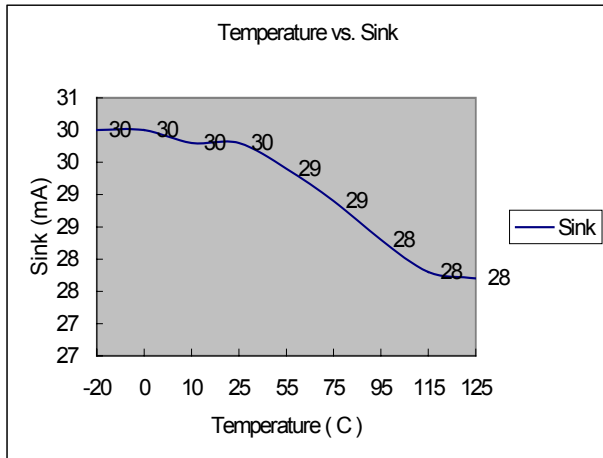
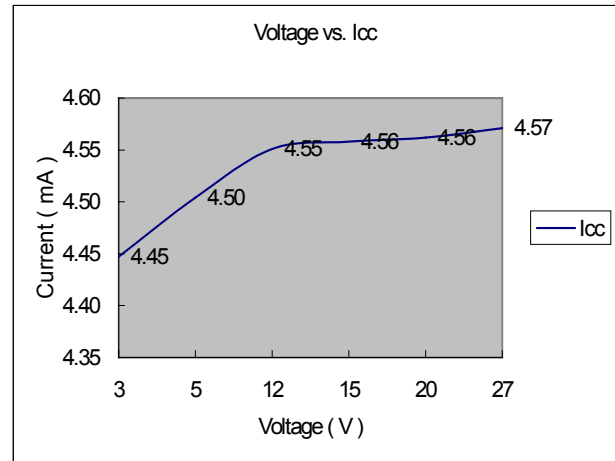
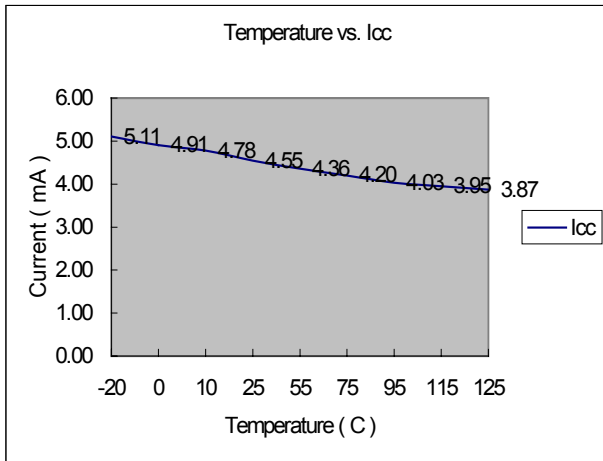
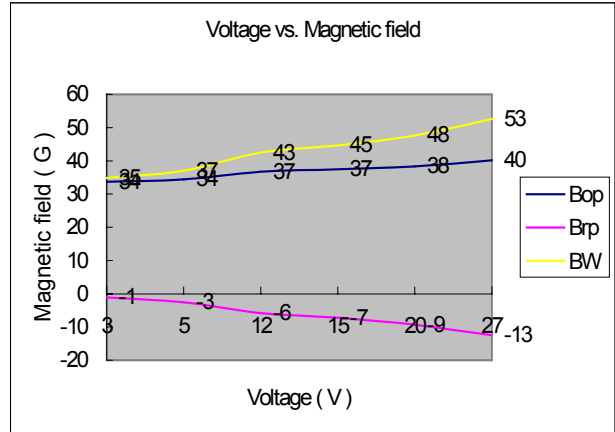
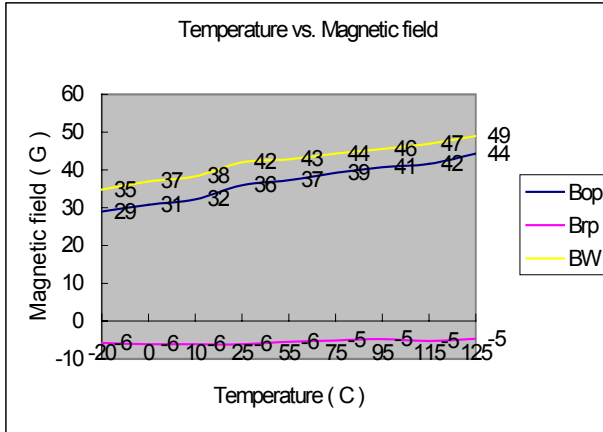

■ TYPICAL CHARACTERISTICS(Cont.)

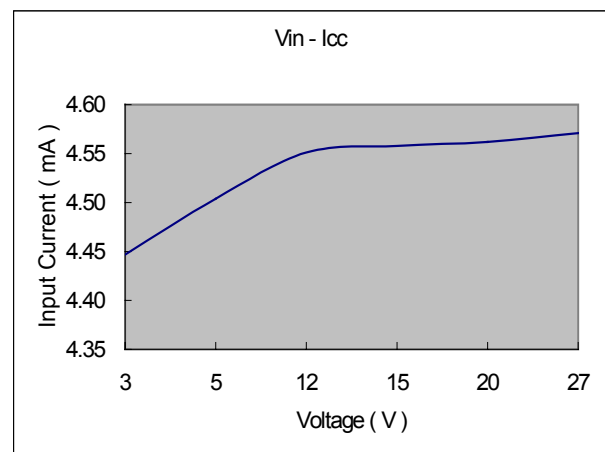
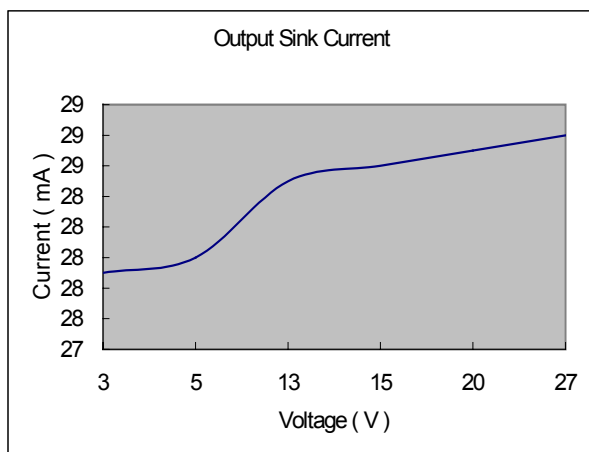
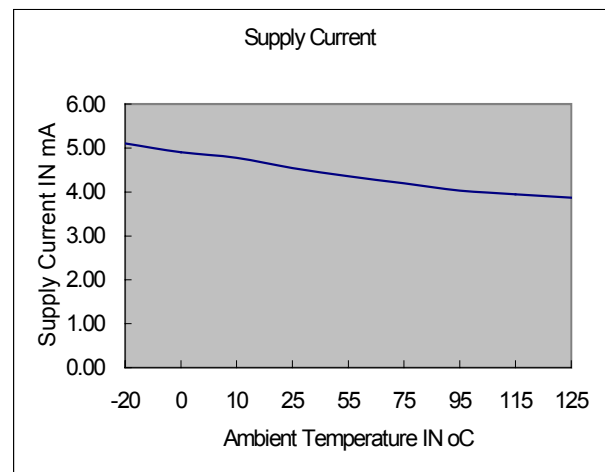
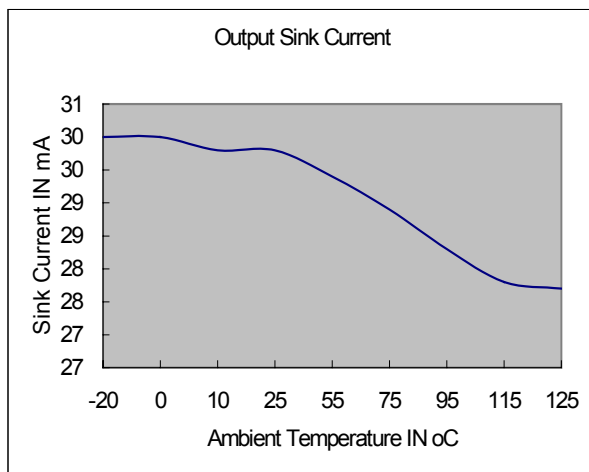
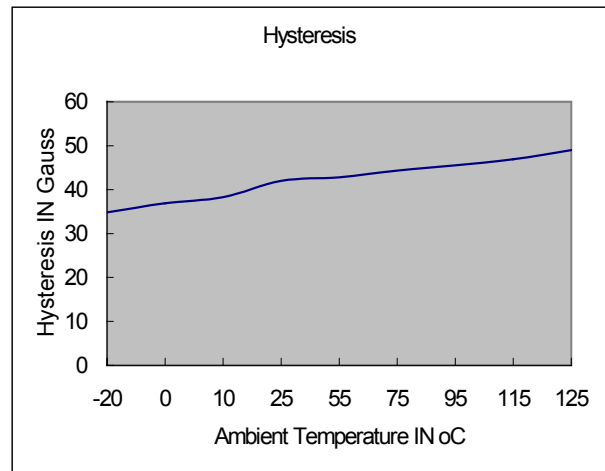
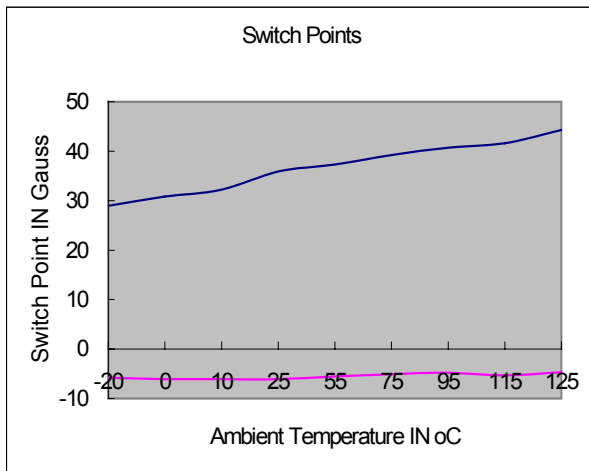

UTC assumes no responsibility for equipment failures that result from using products at values that exceed, even momentarily, rated values (such as maximum ratings, operating condition ranges, or other parameters) listed in products specifications of any and all UTC products described or contained herein. UTC products are not designed for use in life support appliances, devices or systems where malfunction of these products can be reasonably expected to result in personal injury. Reproduction in whole or in part is prohibited without the prior written consent of the copyright owner. The information presented in this document does not form part of any quotation or contract, is believed to be accurate and reliable and may be changed without notice.