

FEATURES

- Wide supply voltage operating range: 1.8 to 15V
- Reference voltage precision: 4%
- Low current consumption:
Operation Mode 5.5mA
Standby Mode: 1µA
- High speed oscillator frequency: 1MHz max
- Programmable Soft Start function (SS)
- Short Circuit Protection function (SCP)
- Totem-pole output with adjustable on/off current (for NPN transistors or n-channel MOSFET)
- Logic level control stand-by mode function
- Package: SOP8/MSOP8/TSSOP8

TYPICAL APPLICATION

- Digital Camera
- PDA
- Portable Equipment

GENERAL DESCRIPTION

The LSP3601 is a boost topology switching regulator control IC for battery-used applications field. The LSP3601 includes a totem-pole single output stage for driving NPN transistor or N-MOS, high precision reference (0.5V) for comparing output voltage with feedback amplifier, an internal dead-time control for controlling the minimum duty cycle, programmable soft start with short circuit protection function and logic level control for operating mode or standby mode.

PIN ASSIGNMENT

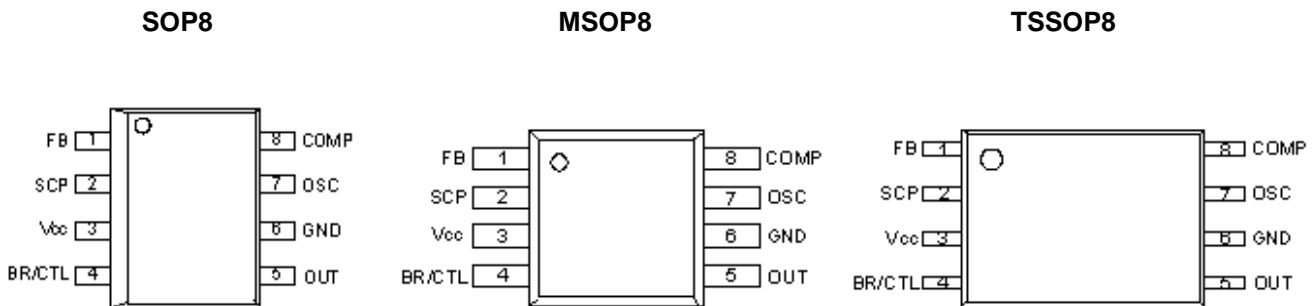

PIN DESCRIPTION

Name	No.	I/O	Description
FB	1	I	Error amplifier inverting input pin
SCP	2	I	Connected a capacitor Soft start and SCP function pin
V _{CC}	3	P	IC Power supply
BR/CTL	4	I	Output current setting and control pin
OUT	5	O	Totem-pole output
GND	6	P	IC ground
OSC	7	I	Capacitor and resistor connected for the frequency of oscillation
COMP	8	O	Error amplifier compensation output

FUNCTIONAL BLOCK DIAGRAM

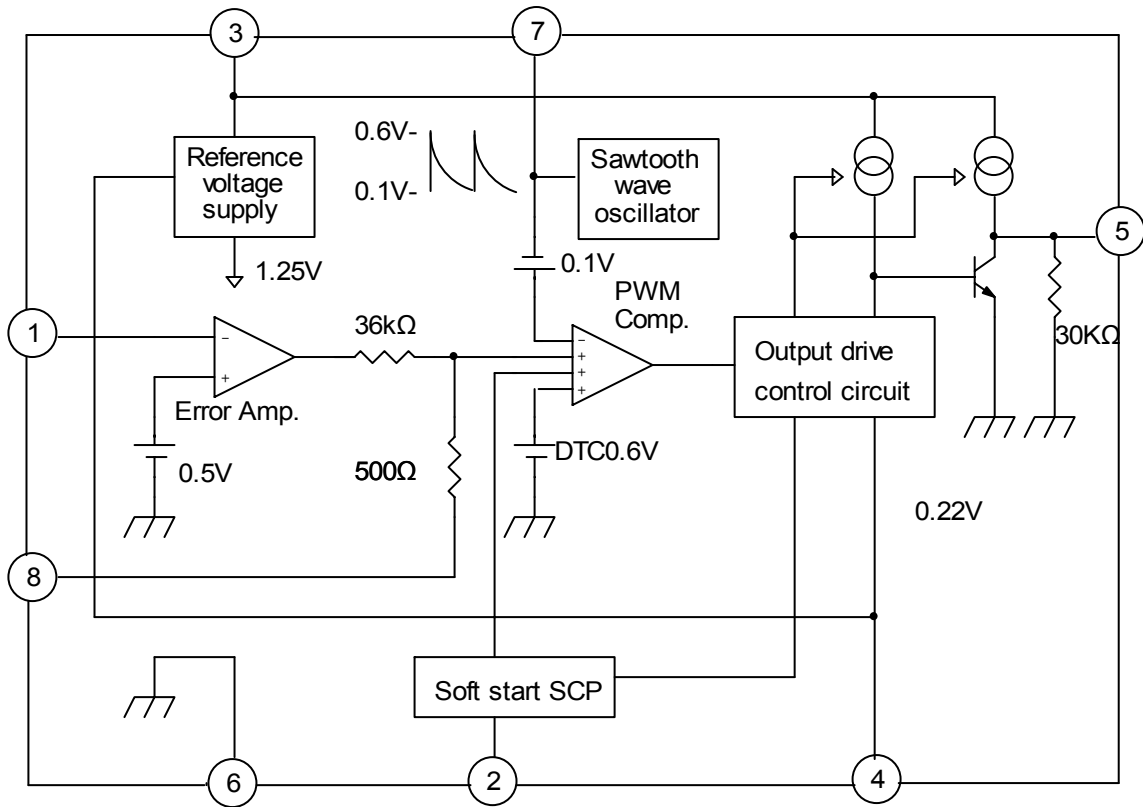

ABSOLUTE MAXIMUM RATINGS

Power supply voltage	+15V		
Output source current	-50mA		
Output sink current	+50mA		
Allowable dissipation	SOP8	T_a +25	570mW
	MSOP8	T_a +25	400mW
	TSSOP8	T_a +25	400mW
Operating temperature	-10 +85		
Storage temperature	-55 +125		
SOP8 lead Temperature (soldering, 10 sec)	+260		
TSSOP8 Lead Temperature (soldering, 10 sec)	+260		
MSOP8Lead Temperature (soldering, 10 sec)	+260		

DC Electrical Characteristics

Under Voltage Lock-Out section (U.V.L.O.)

Parameter	Symbol	Test Conditions	Min.	Typ.	Max.	Unit
Low threshold voltage	V_{LOW}				0.9	V
Upper threshold voltage	V_{UPPER}		1.1	1.3	1.5	V

Soft Start section (S.S.)

Parameter	Symbol	Test Conditions	Min.	Typ.	Max.	Unit
Input source current	I_{SS}	$V_{SCP}=0V$	-1.5	-1.0	-0.7	μA
Soft start threshold voltage	V_{SST}		0.8	0.9	1.0	V



Liteon Semiconductor Corporation

LSP3601

Step-Up DC/DC Controller

■ DC ELECTRICAL CHARACTERISTICS (CONTINUED)

Short Circuit Protection section (S.C.P.)

Parameter	Symbol	Test Conditions	Min.	Typ.	Max.	Unit
Input source current	I_{SCP}	$V_{SCP}=0V$	-1.5	-1.0	-0.7	μA
S.C.P. threshold voltage	V_{SCP}		0.7	0.8	0.9	V

Oscillator section

Parameter	Symbol	Test Conditions	Min.	Typ.	Max.	Unit
Oscillation frequency	f	$R_T=3.0K\Omega, C_T=270pF$	400	500	600	KHz
Frequency change with voltage	$\Delta f/\Delta V$	$V_{CC}=2V$ to 15V		2	10	%
Frequency change with temperature	$\Delta f/\Delta T$	$T_a=0$ to 85		5		%

Idle Period Adjustment section

Parameter	Symbol	Test Conditions	Min.	Typ.	Max.	Unit
Maximum duty cycle	T_{DUTY}	$R_T=3.0K\Omega, C_T=270pF, V_{FB}=0.8V$	75		85	%

Total device section

Parameter	Symbol	Test Conditions	Min.	Typ.	Max.	Unit
Stand-by current	$I_{STANDBY}$	Pin4 is open or V_{CC}			1	μA
Average supply current	I_{AVE}	$R_B=390\Omega, V_{CC}=0$ 20V		5.0	10	mA

Error Amplifier section

Parameter	Symbol	Test Conditions	Min.	Typ.	Max.	Unit
Input threshold voltage	V_{FB}	$V_{COMP}=450mV$	480	500	520	mV
V_T change with voltage	$\Delta V_{FB}/\Delta V$	$V_{CC}=2V$ to 15V		5	20	mV
V_T change with temperature	$\Delta V_{FB}/\Delta V$	$T_a=-10$ to 85		1		%
Input basic current	I_B		-1.0	-0.2	1.0	μA
Voltage Gain	A_V			100		V/V
Frequency bandwidth	BW	$A_V=0dB$		6		MHz
Output voltage Swing	Positive	$V_{COMP}=450mV$	0.78	0.87	0.2	V
	Negative			V_{NEG}		
Output source current	I_{SOURCE}	$V_{COMP}=450mV$	24	-40	-24	μA
Output sink current	I_{SINK}			40		μA

Output section

Parameter	Symbol	Test Conditions	Min.	Typ.	Max.	Unit
Output high voltage	V_{OH1}	$R_B=390\Omega, I_O=-15mA$	1.0	1.2		V
Output high voltage	V_{OH2}	$R_B=750\Omega, I_O=-10mA, V_{CC}=1.8V$	0.8	1.0		V
Output saturation voltage	V_{O11}	$R_B=390\Omega, I_O=15mA$		0.1	0.2	V
Output saturation voltage	V_{O12}	$R_B=750\Omega, I_O=10mA, V_{CC}=1.8V$		0.1	0.2	V
Output source current	$I_{OSOURCE}$	$R_B=390\Omega, V_O=-0.9V$		-40	-20	mA
Output sink current	I_{OSINK}	$R_B=390\Omega, V_O=-0.3V$	30	40		mA
Internal pull-down resistor	R_O		20	30	40	K Ω

Output Current Setting / Control section

Parameter	Symbol	Test Conditions	Min.	Typ.	Max.	Unit
Pin voltage	V_{BR}	$R_B=390\Omega$	0.15	0.22	0.3	V
Input off condition	I_{OFF}		-20		0	μA
Input on condition	I_{ON}				-4.5	μA
Pin current range	I_{BR}		-1.8		-0.1	mA

■ TYPICAL CHARACTERISTICS

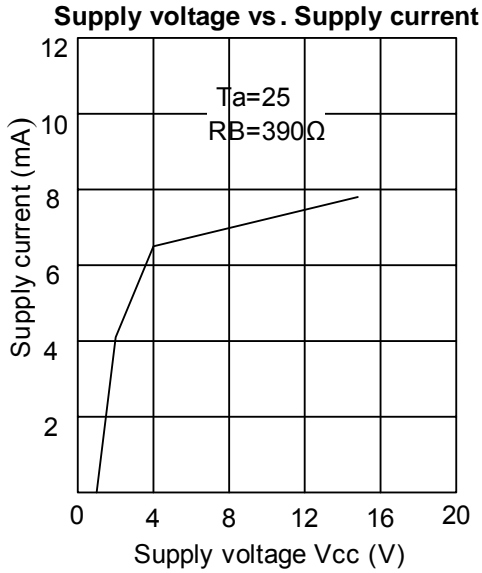

Figure 1

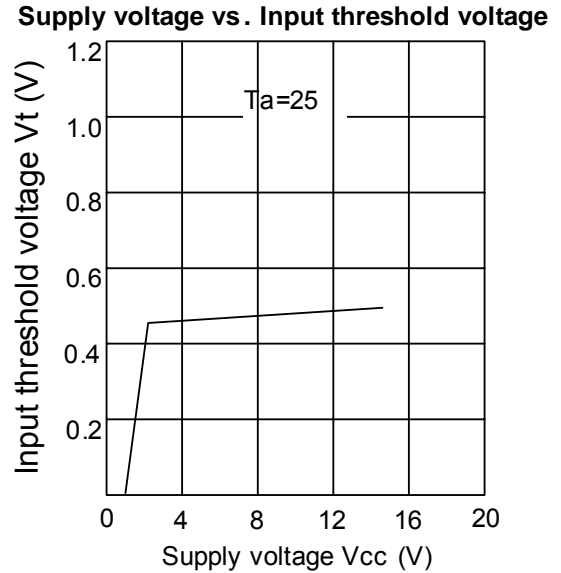

Figure 2

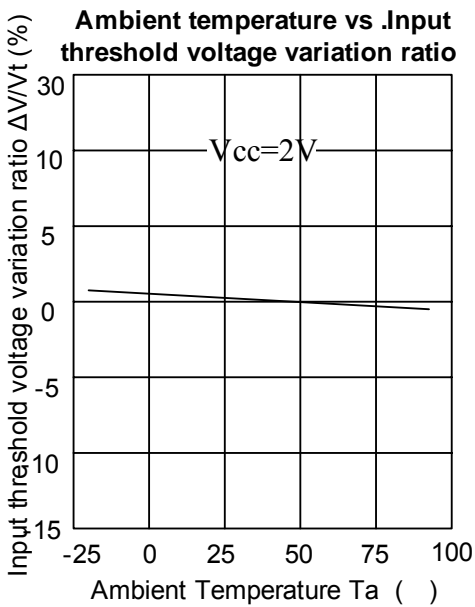

Figure 3

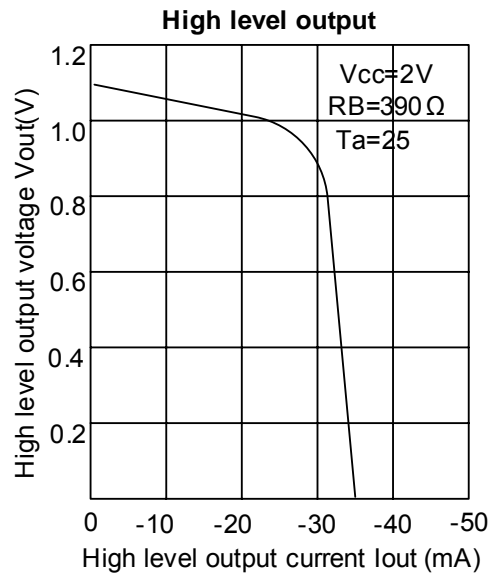

Figure 4

■ TYPICAL CHARACTERISTICS (CONTINUED)

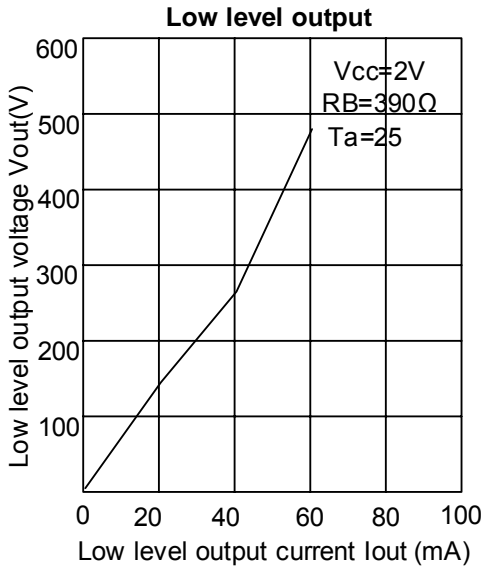

Figure 5

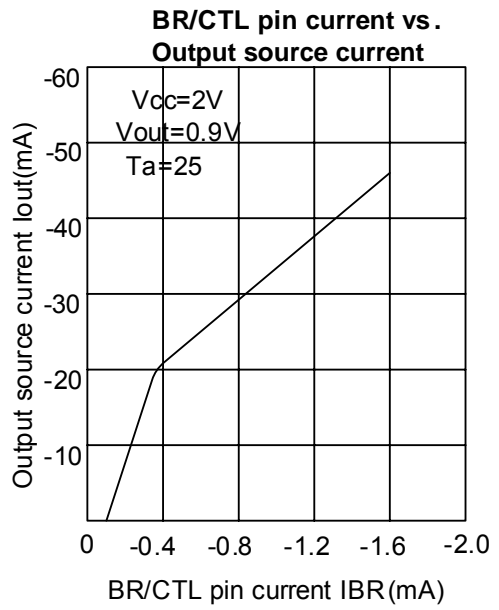

Figure 6

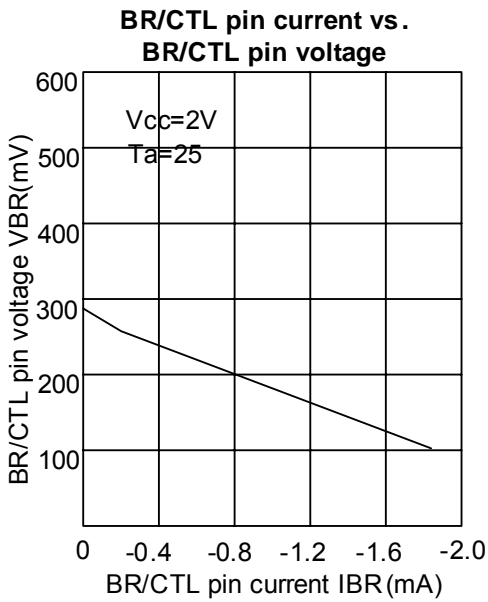

Figure 7

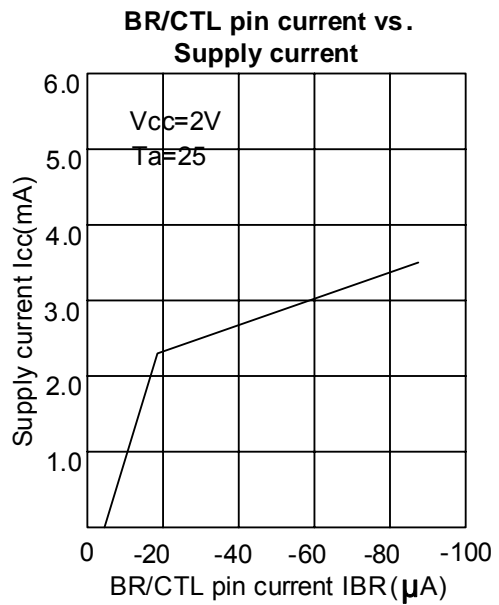

Figure 8

■ TYPICAL CHARACTERISTICS (CONTINUED)

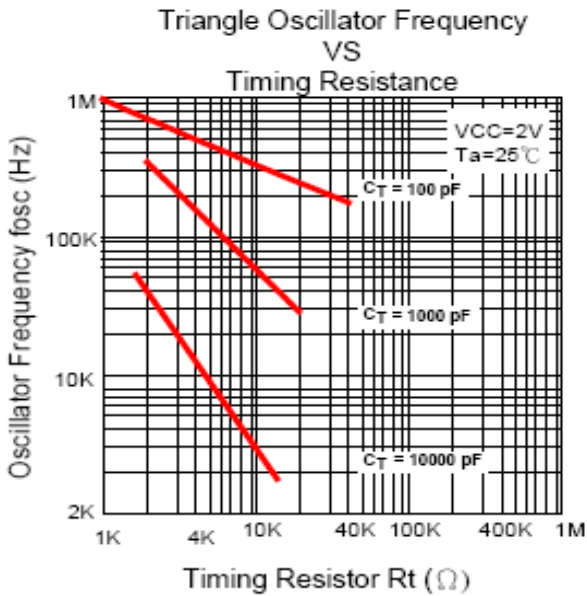

Figure 9

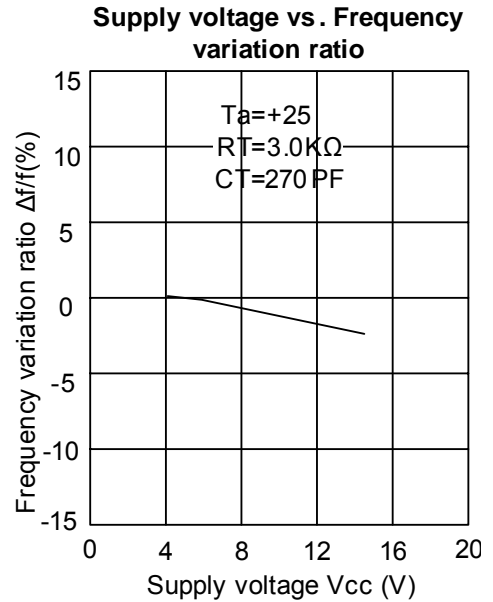

Figure 10

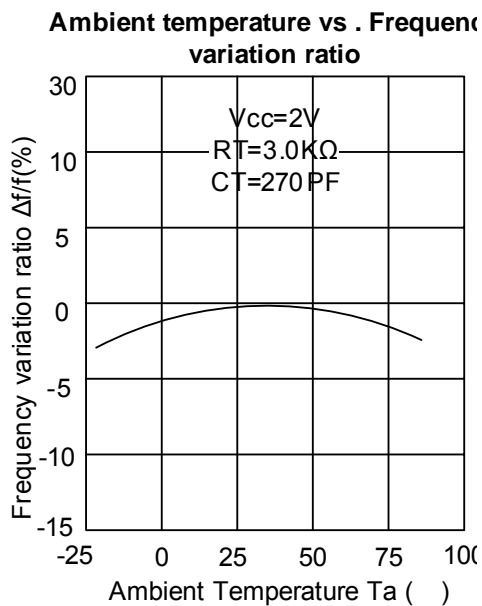
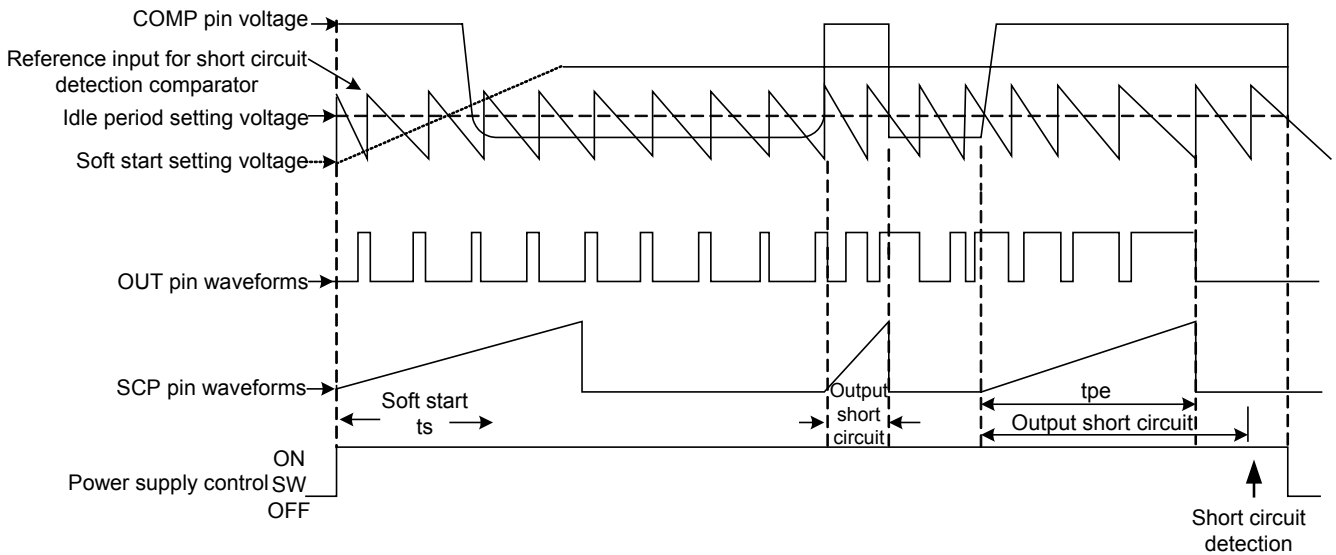

Figure 11

■ TIMING WAVEFORM



■ DETAILED DESCRIPTION

Voltage reference

A 1.25V regulator operating from V_{CC} is used to power the internal circuitry of the LSP3601. An internal resistor divider provides 0.5V reference for the error amplifier, Soft-start (typ. 0.9V) and SCP (typ. 0.8V).

Error amplifier

The error amplifier compares a sample of the dc-dc converter output voltage to the 0.5V reference and generates an error signal for the PWM comparator. Output voltage of the dc-dc converter is setting with the resistor divider using the following expression (see fig12):

$$V_{OUT} = (1 + R_1 / R_2) * 0.5$$

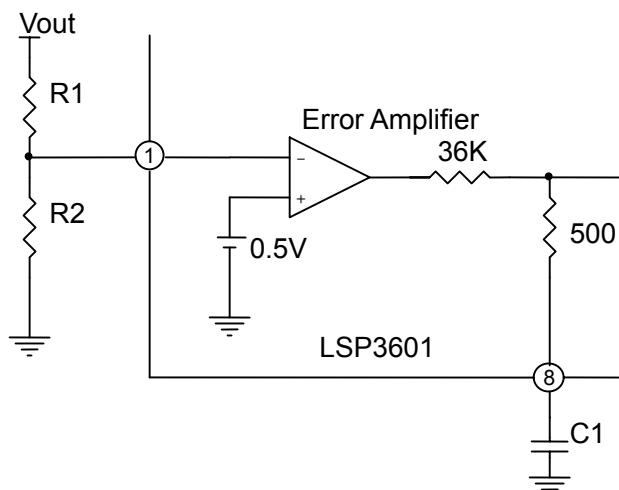

Figure 12. Error Amplifier with Feedback resistance divider

Oscillator

The oscillator frequency can be set between 20 KHz and 500 KHz by connecting a resistor and a capacitor at OSC pin of LSP3601 to ground. The oscillator frequency can be determined by using the graph shown in figure 9.

The oscillator output is a sawtooth wave with a minimum value of approximately 0.1V and a maximum value of approximately 0.6V. The PWM comparator compares the oscillator voltage with error amplifier output voltage; internal

DTC voltage (typ.0.6V) and soft start setting voltage. When the sawtooth wave is lower than the above three output voltage, the output of LSP3601 is high (Turn on NPN transistor or NMOS).

Under voltage lockout (UVLO)

The under voltage lockout circuits turn the output off whenever the supply voltage drop too low (approximately 0.9V at 25) for proper operation .A hysteresis voltage of 200 mV eliminates false triggering on noise and chattering.

Soft Start / Short-circuit protection (S.S. / S.C.P.)

The soft start is function after power on, and the interval of the soft start time is determined by capacitor connected to SCP pin (pin 2). When soft start function finished, the internal soft start voltage is setting high, but external SCP pin is setting low in order to change to short circuit detection / protection function.

The time of soft start is following expression:

$$T_{SS}=0.35 * C[\mu F]$$

The short circuit protection is functional due to a heavy loading drop and output of error amplifier (COMP pin) is maintain a V_{POS} (typ.0.87V), the capacitor is charged until SCP threshold voltage (typ.0.8V), then LSP3601 output is disable (internal pull-low) and the capacitor is discharged to low .

The time of short circuit protection is following expression:

$$T_{SCP}=0.8 * C[\mu F]$$

Output transistor

The LSP3601 has a totem-pole transistor with a 40 mA source/sink current rating to drive an external NPN transistor or NMOS transistor directly. The driving current capability depends on a resistor R that is connected to BR/CTL pin (pin4) of LSP3601. (see fig.13)

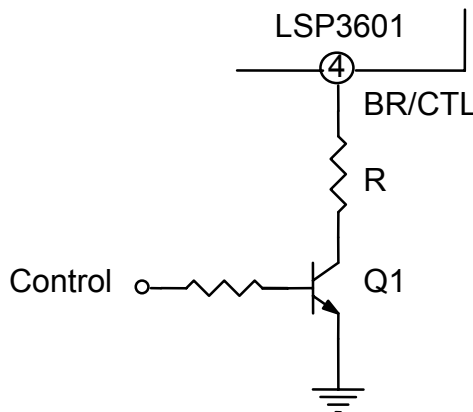

Figure13. Output transistor driving control circuit

BR/CTL pin can also use to control the output of LSP3601 for disable or enable function of system.

Control Pin	Q1	BR/CTL Pin	Output Transistor Function	Mode
Low	Off	Open	Disable	Stand-by
High	On	Bias Current	Enable	Operation

■ APPLICATION NOTE (1)

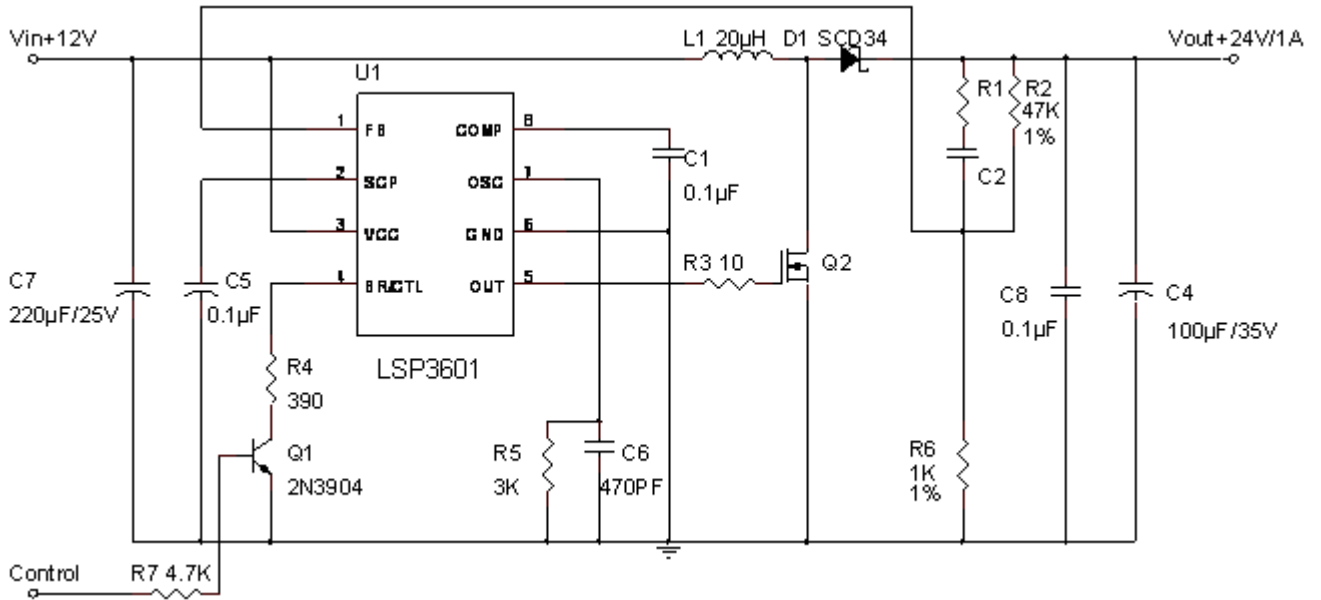

Figure 14. DC 12V to DC 24V Boost Regulator

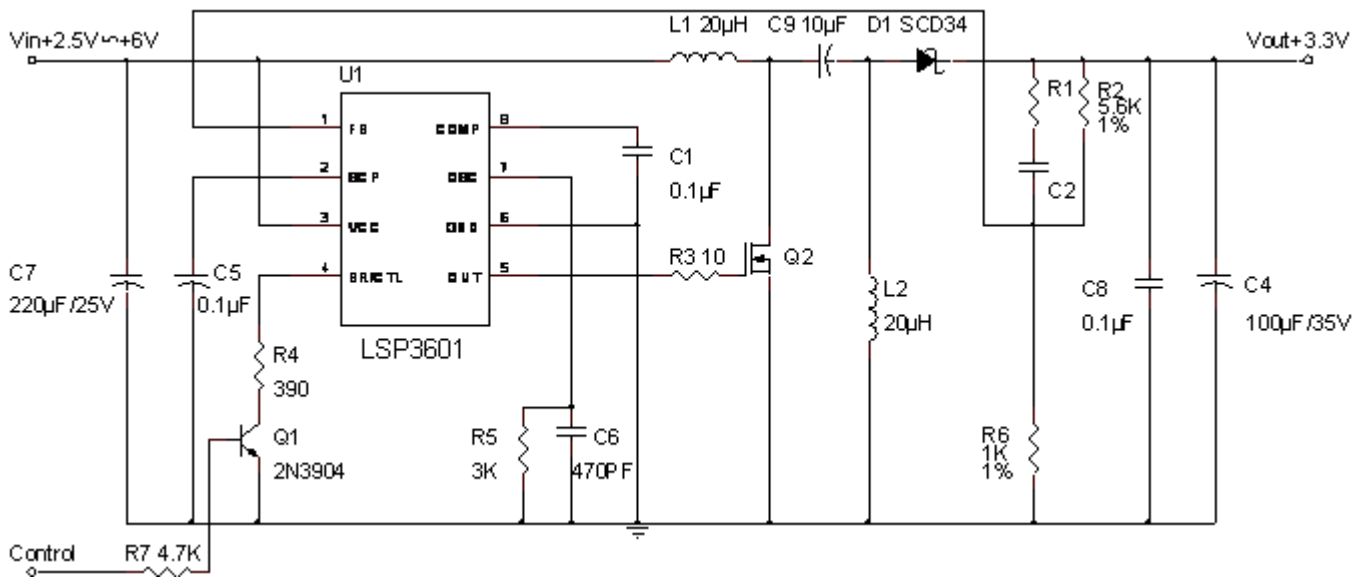

Figure 15. DC 2.5V DC 6V to DC 3.3V SEPIC Regulator

■ APPLICATION NOTE (2)

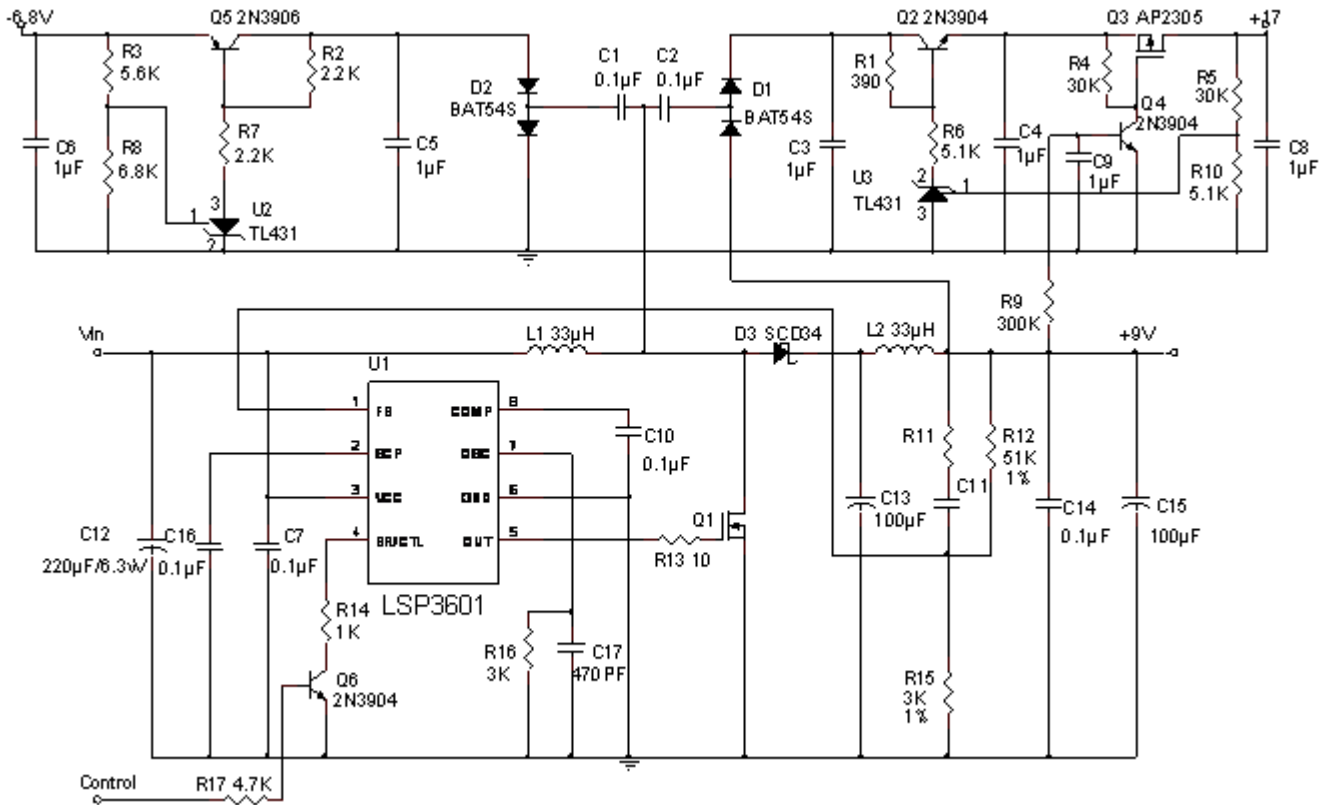
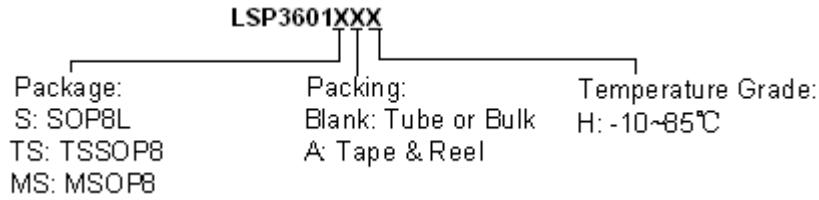

Figure16. Charge Pump DC-DC Converter Circuits

ORDERING INFORMATION



MARKING INFORMATION

1) SOP-8L

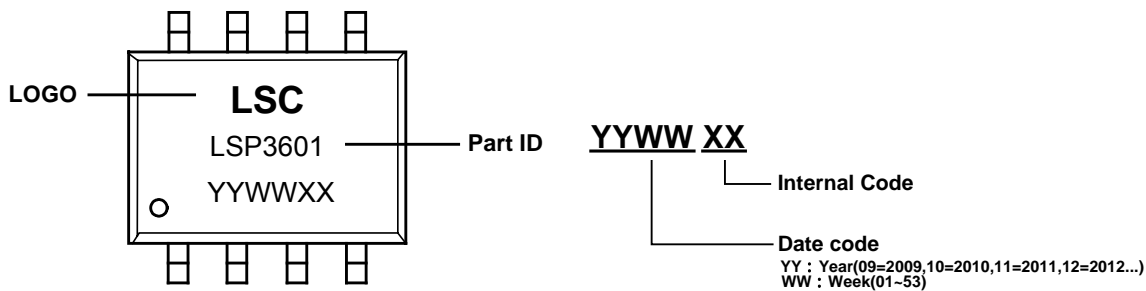

2) MSOP-8L

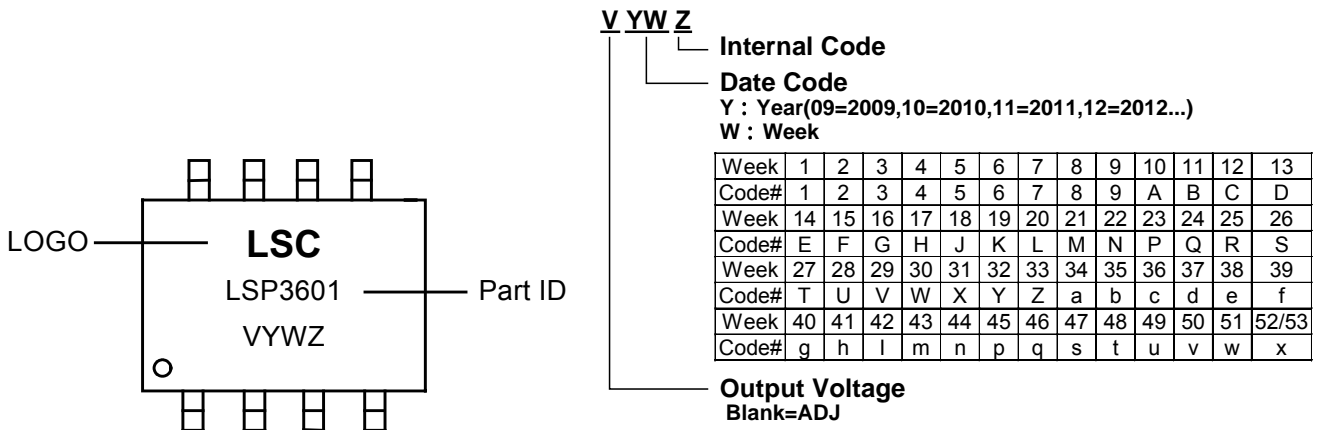

3) TSSOP-8L

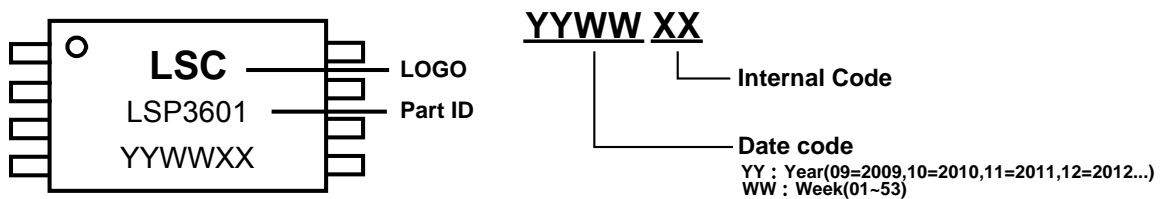

■ PACKAGE INFORMATION

1) SOP8

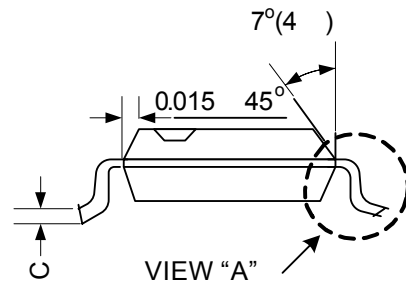
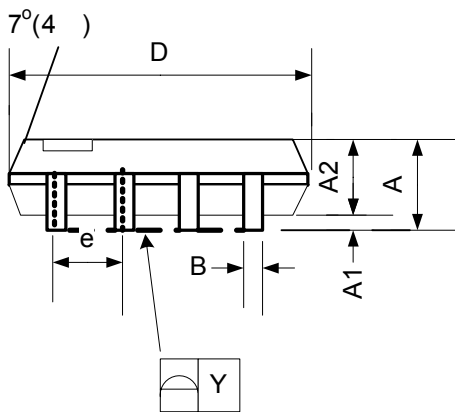
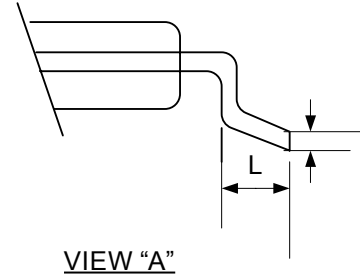
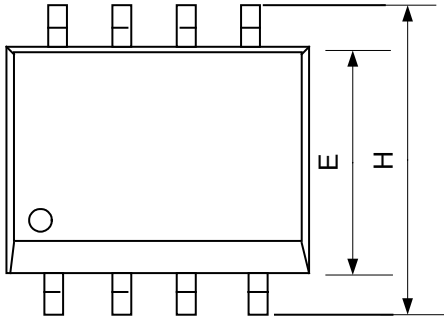

Symbol	Dimensions In Millimeters			Dimensions In Inches		
	Min.	Nom.	Max.	Min.	Nom.	Max.
A	1.40	1.60	1.75	0.055	0.063	0.069
A1	0.10		0.25	0.004		0.010
A2	1.30	1.45	1.50	0.051	0.057	0.059
B	0.33	0.41	0.51	0.013	0.016	0.020
C	0.19	0.20	0.25	0.0075	0.008	0.010
D	4.80	5.05	5.30	0.189	0.199	0.209
E	3.70	3.90	4.10	0.146	0.154	0.161
e		1.27			0.050	
H	5.79	5.99	6.20	0.228	0.236	0.244
L	0.38	0.71	1.27	0.015	0.028	0.050
Y			0.10			0.004
θ	0°		8°	0°		8°

2) MSOP8

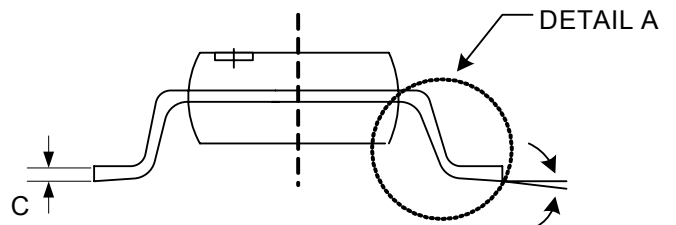
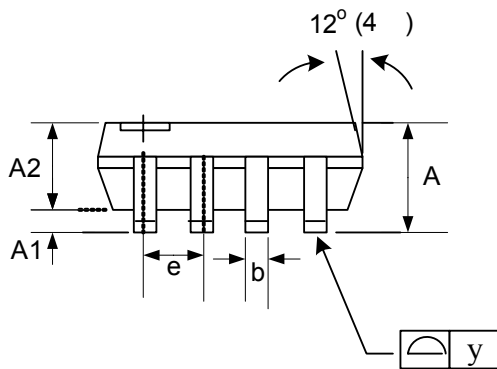
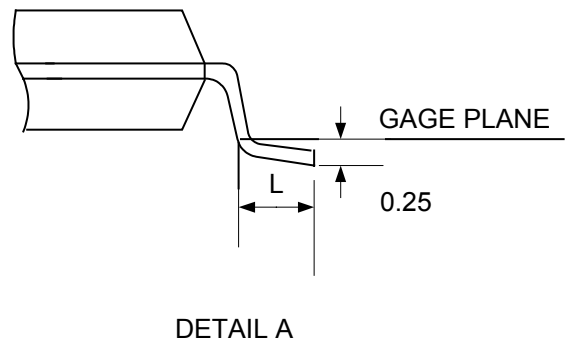
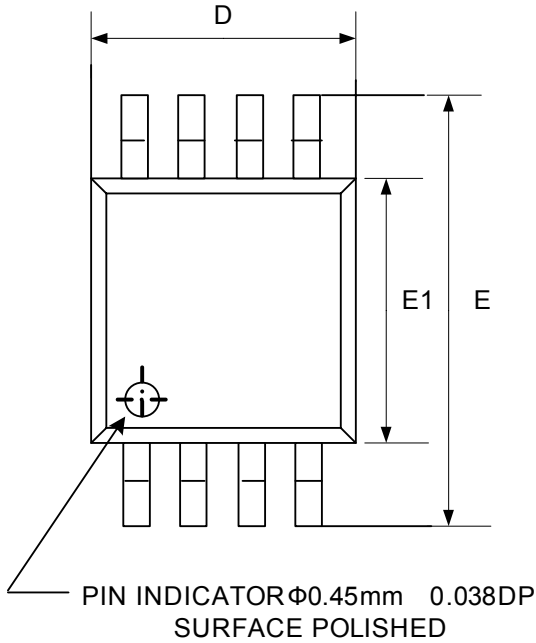

Symbol	Dimensions In Millimeters			Dimensions In Inches		
	Min.	Nom.	Max.	Min.	Nom.	Max.
A	0.81	1.02	1.22	0.032	0.040	0.048
A1	0.05		0.15	0.002		0.006
A2	0.76	0.86	0.97	0.030	0.034	0.038
b	0.28	0.30	0.38	0.011	0.012	0.015
C	0.13	0.15	0.23	0.005	0.006	0.009
D	2.90	3.00	3.10	0.114	0.118	0.122
E	4.80	4.90	5.00	0.189	0.193	0.197
E1	2.90	3.00	3.10	0.114	0.118	0.122
e		0.65			0.0256	
L	0.40	0.53	0.66	0.016	0.021	0.026
y			0.076			0.003
θ	0°	3°	6°	0°	3°	6°

3) TSSOP8

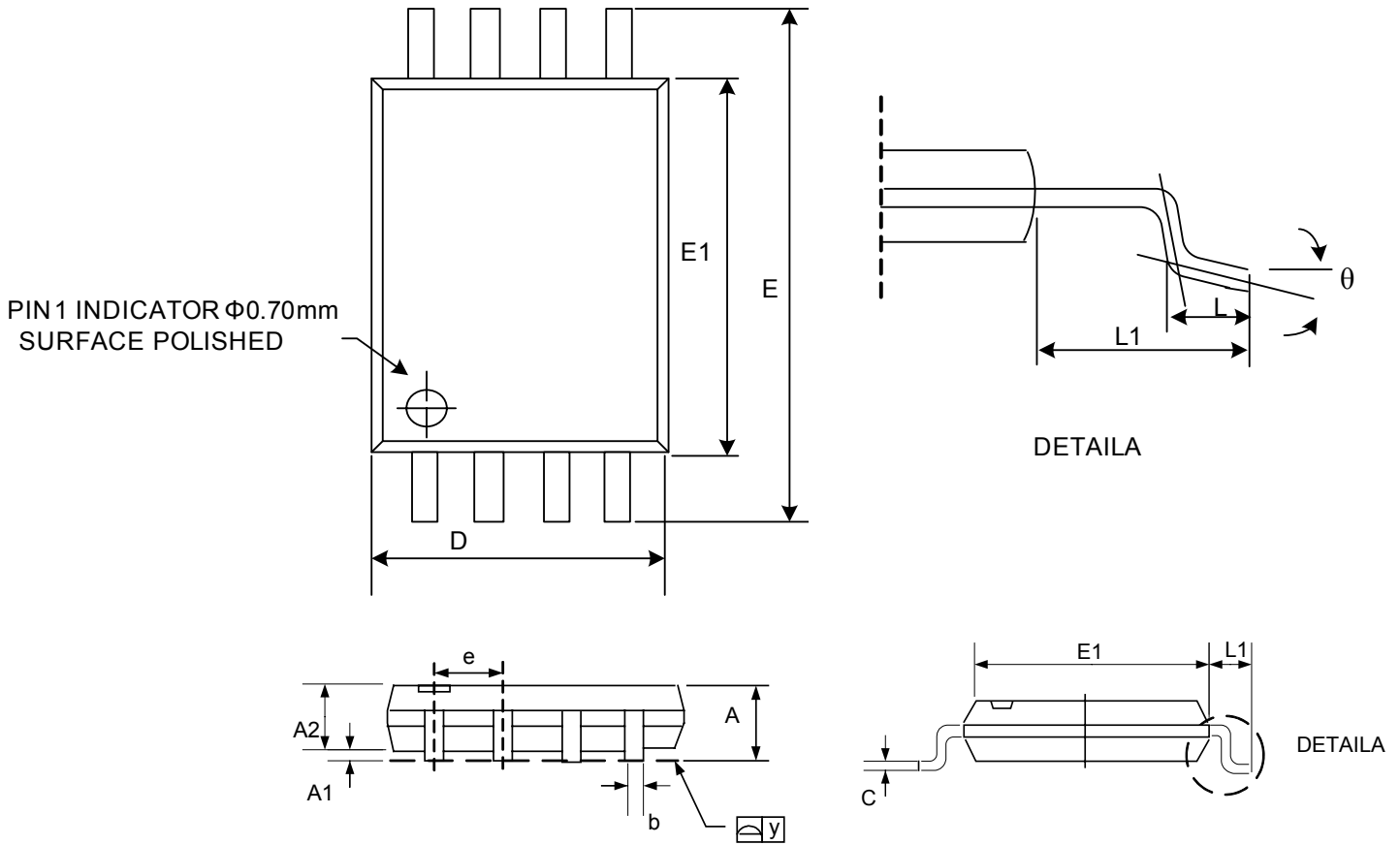

Symbol	Dimensions In Millimeters			Dimensions In Inches		
	Min.	Nom.	Max.	Min.	Nom.	Max.
A	1.05	1.10	1.20	0.041	0.043	0.047
A1	0.05	0.10	0.15	0.002	0.004	0.006
A2		1.00	1.05		0.039	0.041
b	0.20	0.25	0.28	0.008	0.01	0.011
C		0.13			0.005	
D	2.90	3.05	3.10	0.114	0.12	0.122
E	6.20	6.40	6.60	0.244	0.252	0.26
E1	4.30	4.40	4.50	0.169	0.173	0.177
e		0.65			0.026	
L	0.50	0.60	0.70	0.02	0.024	0.028
L1	0.90	1.00	1.10	0.035	0.039	0.043
y			0.10			0.004
	0°	4°	8°	0°	4°	8°