

■ FEATURES

- Output voltage: 3.3V, 5.0V, 12V, and adjustable output version
- Adjustable version output voltage range: 1.23V to 37V±4%
- 150KHz±15% fixed switching frequency
- Voltage mode non-synchronous PWM control
- Thermal-shutdown and current-limit protection
- ON/OFF shutdown control input
- Operating voltage can be up to 40V
- Output load current: 3A
- Low power standby mode
- Built-in switching transistor on chip
- TO220-5L , TO252-5L and TO263-5L packages

■ APPLICATIONS

- Simple High-efficiency step-down regulator
- On-card switching regulators
- Positive to negative converter

■ PIN CONFIGURATION

(1) TO220-5L

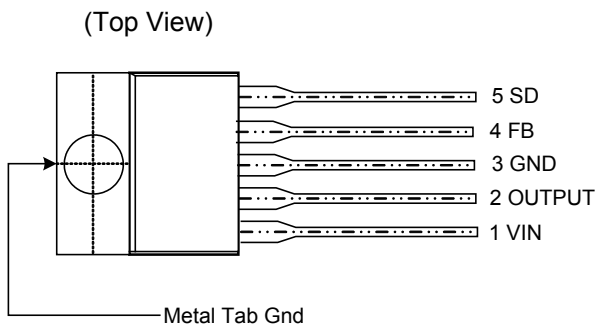

(2) TO252-5L

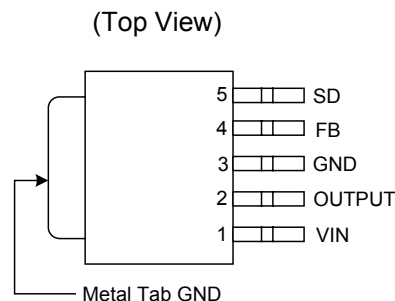

(3) TO263-5L

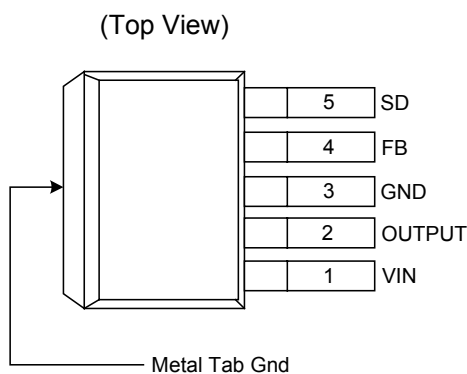

Symbol	Name	Descriptions
1	Vin	Operating Voltage Input
2	Output	Switching Output
3	Gnd	Ground
4	FB	Output Voltage Feedback Control
5	SD	ON/OFF Shutdown

■ BLOCK DIAGRAM

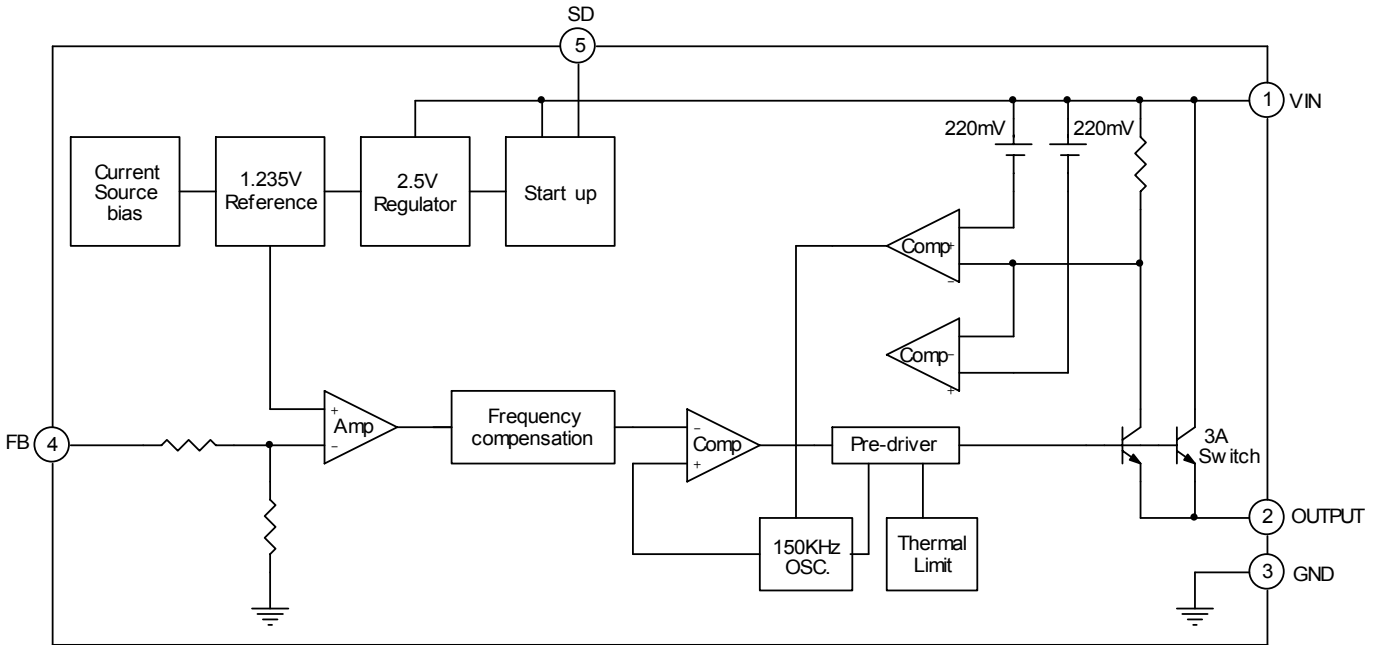

■ ABSOLUTE MAXIMUM RATINGS

Symbol	Paramrter	Rating	Unit
V_{CC}	Supply Voltage	+45	V
V_{SD}	ON/OFF Pin input Voltage	-0.3 to +25	V
V_{FB}	Feedback Pin Voltage	-0.3 to +25	V
V_{OUT}	Output Voltage to Ground	-1	V
P_D	Power Dissipation	Internally Limited	W
T_{ST}	Storage Temperature	-65 to +150	
T_{OP}	Operating Temperature	-40 to +125	
V_{OP}	Operating Voltage	+4.5 to +40	V



Liteon Semiconductor Corporation

LSP3122

150KHZ 3A PWM Buck DC/DC Converter

■ ELECTRICAL CHARACTERISTICS (ALL OUTPUT VOLTAGE VERSIONS)

Unless otherwise specified, $V_{IN}=12V$ for 3.3V, 5V, adjustable version and $V_{IN}=24V$ for the 12V version. $I_{LOAD}=0.5A$

Symbol	Parameter		Conditions	Min.	Typ.	Max.	Unit
I_B	Feedback bias current		$V_{FB}=1.3V$ (Adjustable version only)		40	50 100	nA
F_{OSC}	Oscillator frequency			127 110	150	173 173	KHz
V_{SAT}	Saturation voltage		$I_{OUT}=3A$ no outside circuit $V_{FB}=0V$ force driver on		1.16	1.4	V
DC	Max.Duty Cycle(ON)		$V_{FB}=0V$ force driver on			100	%
	Min.Duty Cycle(OFF)		$V_{FB}=12V$ force driver off	0			
I_{CL}	Current limit		Peak current no outside circuit $V_{FB}=0V$ force driver on	3.6		6.9	A
I_L	Output=0	Output leakage current	no outside circuit $V_{FB}=12V$ force driver off			50	μA
	Output=-1		$V_{IN}=40V$		5	30	mA
I_Q	Quiescent Current		$V_{FB}=12V$ force driver off		7.8	10	mA
I_{STBY}	Standby Quiescent Current		ON/OFF Pin=5V $V_{IN}=40V$		85	200	μA
V_{IL}	ON/OFF pin logic input threshold voltage		Low(regultaor ON)		1.4	0.6	V
V_{IH}			High(regultaor OFF)	2.0			
I_H	ON/OFF pin logic input current		$V_{LOGIC}=2.5V$ (OFF)		6	15	μA
I_L	ON/OFF pin input current		$V_{LOGIC}=0.5V$ (ON)		0.02	5	
θ_{JC}	Thermal Resistance		TO252-5L	Junction to case		10	/W
			TO220-5L			2.5	
			TO263-5L			3.5	
θ_{JA}	Thermal Resistance With copper area of approximately 3 in ²		TO252-5L	Junction to ambient		30	/W
			TO220-5L			28	
			TO263-5L			30	

■ ELECTRICAL CHARACTERISTICS (CONTINUED)

	Symbol	Parameter	Conditions	Typ.	Limit	Unit
LSP3122-ADJ	V_{FB}	Output Feedback	$4.5V \leq V_{IN} \leq 40V$ $0.2A \leq I_{LOAD} \leq 3A$ V_{OUT} programmed for 3V	1.23	1.193/1.18 1.267/1.28	V V_{MIN} V_{MAX}
	η	Efficiency	$V_{IN} = 12V, I_{LOAD} = 3A$	72		%
LSP3122-3.3V	V_{OUT}	Output voltage	$5V \leq V_{IN} \leq 40V$ $0.2A \leq I_{LOAD} \leq 3A$	3.3	3.168/3.135 3.432/3.465	V V_{MIN} V_{MAX}
	η	Efficiency	$V_{IN} = 12V, I_{LOAD} = 3A$	72		%
LSP3122-5V	V_{OUT}	Output voltage	$7V \leq V_{IN} \leq 40V$ $0.2A \leq I_{LOAD} \leq 3A$	5	4.8/4.75 5.2/5.25	V V_{MIN} V_{MAX}
	η	Efficiency	$V_{IN} = 12V, I_{LOAD} = 3A$	79		%



Liteon Semiconductor Corporation

LSP3122

150KHZ 3A PWM Buck DC/DC Converter

LSP3122-12V	V_{OUT}	Output voltage	$15V \leq V_{IN} \leq 40V$ $0.2A \leq I_{LOAD} \leq 3A$	12	11.52/11.4 12.48/12.6	V_{MIN} V_{MAX}
	η	Efficiency	$V_{IN} = 15V, I_{LOAD} = 3A$	90		%

Specifications with **boldface type** are for full operating temperature range, the other type are for $T_J = 25^\circ C$.

■ TYPICAL PERFORMANCE CHARACTERISTICS

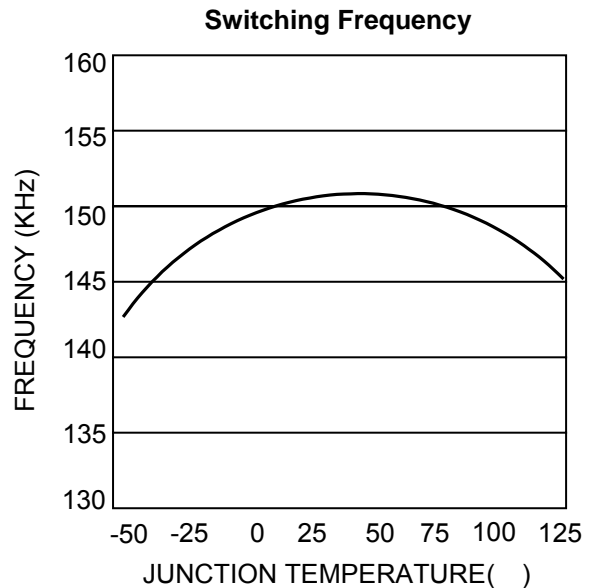
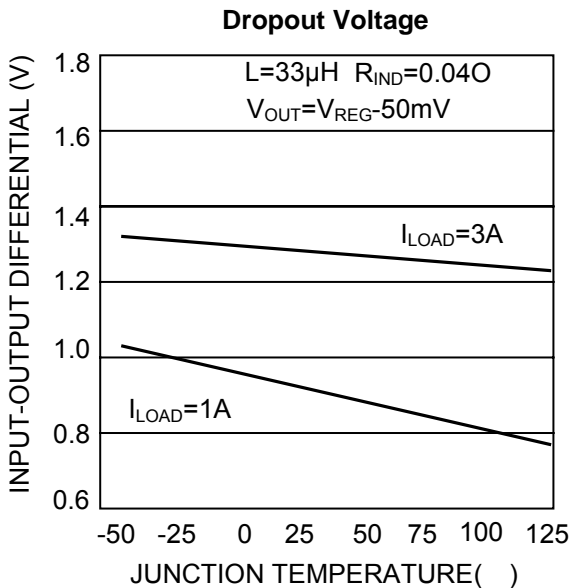
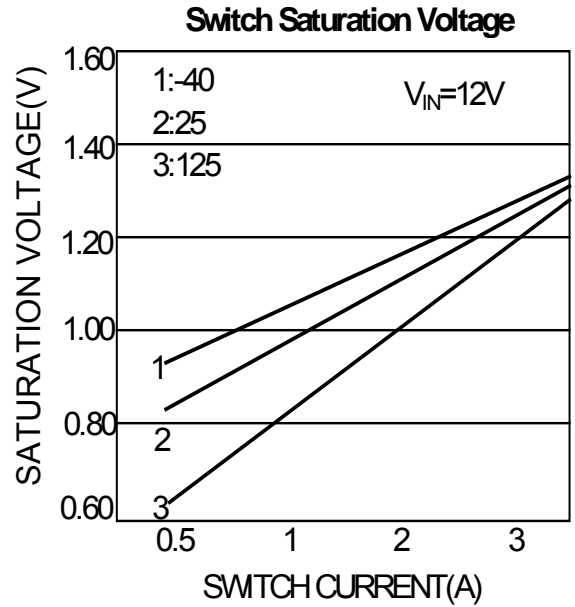
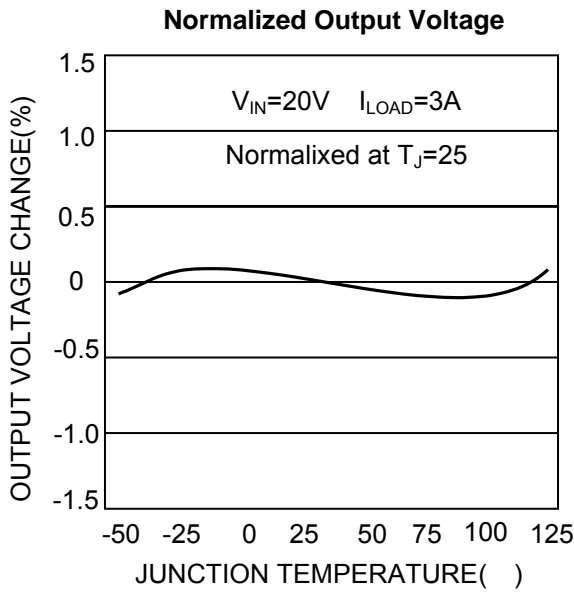

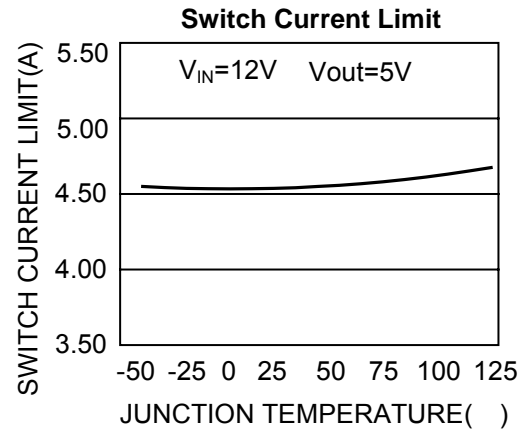
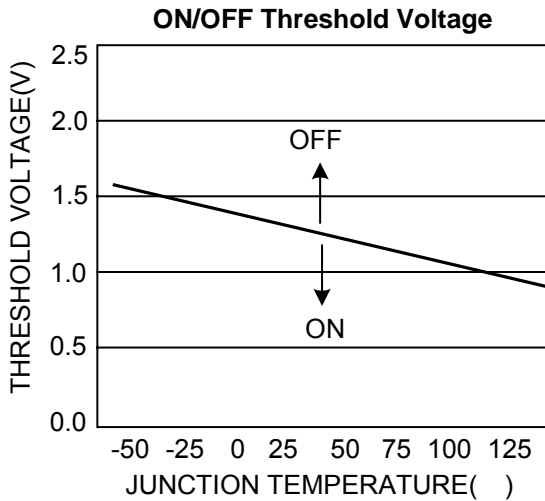

■ TYPICAL APPLICATION CIRCUITS

(1) Fixed Output Circuit

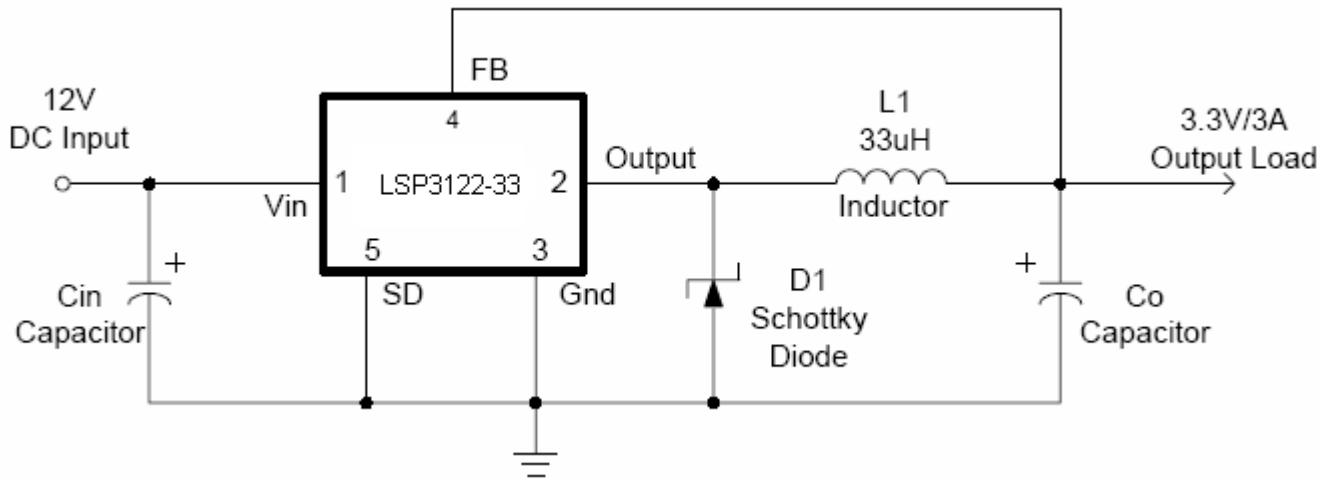

(2) Adjustable Output Circuit

$$V_{out} = V_{FB} * (1 + R1/R2); \quad V_{FB} = 1.23V; \quad R2 = 1K \text{ typical}$$

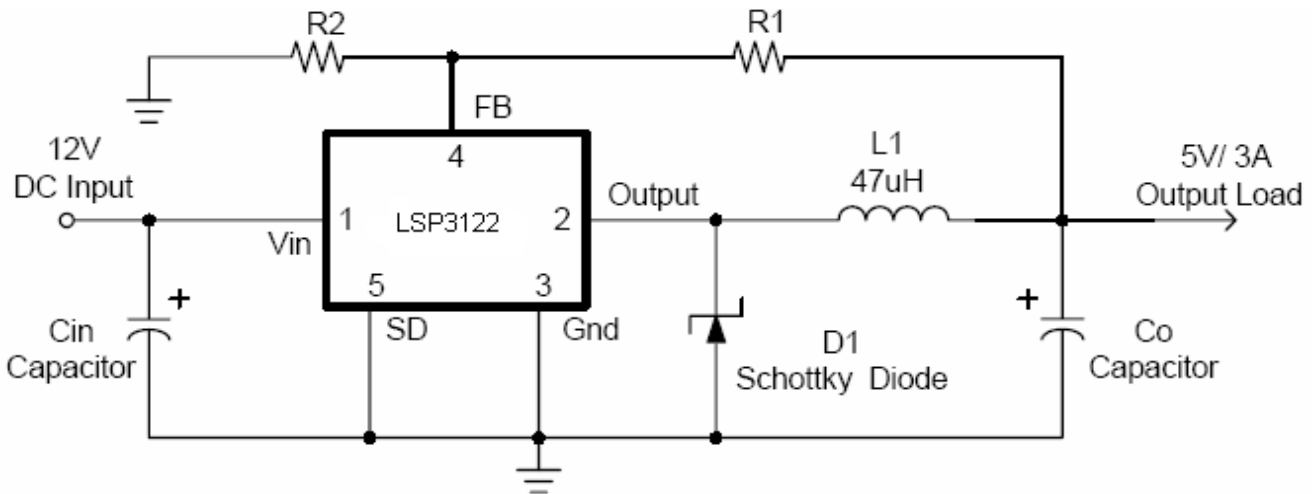

FUNCTION DESCRIPTION

Pin Function

V_{IN}
This is the positive input supply for the IC switching regulator. A suitable input bypass capacitor must be present at this pin to minimize voltage transients and to supply the switching currents needed by the regulator.

Ground
Circuit ground.

Output
Internal switch. The voltage at this pin switches between ($V_{IN} - V_{SAT}$) and approximately $-0.5V$, with a duty cycle of approximately V_{OUT} / V_{IN} . To minimize coupling to sensitive circuitry, the PC board copper area connected to this pin should be kept a minimum.

Feedback
Senses the regulated output voltage to complete the feedback loop.

ON/OFF
Allows the switching regulator circuit to be shutdown using logic level signals thus dropping the total input supply current to approximately 150uA. Pulling this pin below a threshold voltage of approximately 1.3V turns the regulator on, and pulling this pin above 1.3V (up to a maximum of 25V) shuts the regulator down. If this shutdown feature is not needed, the ON/OFF pin can be wired to the ground pin or it can be left open, in either case the regulator will be in the ON condition.

Thermal Considerations
The LSP3122 is available in three packages, a 5-pin TO-220, 5-pin TO252 and a 5-pin surface mount TO-263. The TO-220 package needs a heat sink under most conditions. The size of the heat sink depends on the input voltage, the output voltage, the load current and the ambient temperature. The LSP3122 junction temperature rises above ambient temperature for a 3A load and different input and output voltages. The data for these curves was taken with the LSP3122 (TO-220 package) operating as a buck switching regulator in an ambient temperature of 25°C (still air). These temperature rise numbers are all approximate and there are many factors that can affect these temperatures. Higher ambient temperatures require more heat sinking. The TO-263 surface mount package tab is designed to be soldered to the copper on a printed circuit board. The copper and the board are the heat sink for this package and the other heat producing components, such as the catch diode and inductor. The PC board copper area that the package is soldered to should be at least 0.4 in², and ideally should have 2 or more square inches of 2 oz. Additional copper area improves the thermal characteristics, but with copper areas greater than approximately 6 in², only small improvements in heat dissipation are realized. If further thermal improvements are needed, double sided, multilayer PC board with large copper areas and/or airflow are recommended.

The LSP3122 (TO-263 package) junction temperature rise above ambient temperature with a 2A load for various input and output voltages. This data was taken with the circuit operating as a buck switching regulator with all components mounted on a PC board to simulate the junction temperature under actual operating conditions. This curve can be used for a quick check for the approximate junction temperature for various conditions, but be aware that there are many factors that can affect the junction temperature. When load

150KHZ 3A PWM Buck DC/DC Converter

currents higher than 2A are used, double sided or multilayer PC boards with large copper areas and/or airflow might be needed, especially for high ambient temperatures and high output voltages. For the best thermal performance, wide copper traces and generous amounts of printed circuit board copper should be used in the board layout. (Once exception to this is the output (switch) pin, which should not have large areas of copper.) Large areas of copper provide the best transfer of heat (lower thermal resistance) to the surrounding air, and moving air lowers the thermal resistance even further. Package thermal resistance and junction temperature rise numbers are all approximate, and there are many factors that will affect these numbers. Some of these factors include board size, shape, thickness, position, location, and even board temperature. Other factors are, trace width, total printed circuit copper area, copper thickness, single or double-sided, multilayer board and the amount of solder on the board. The effectiveness of the PC board to dissipate heat also depends on the size, quantity and spacing of other components on the board, as well as whether the surrounding air is still or moving. Furthermore, some of these components such as the catch diode will add heat to the PC board and the heat can vary as the input voltage changes. For the inductor, depending on the physical size, type of core material and the DC resistance, it could either act as a heat sink taking heat away from the board, or it could add heat to the board.

ORDERING INFORMATION

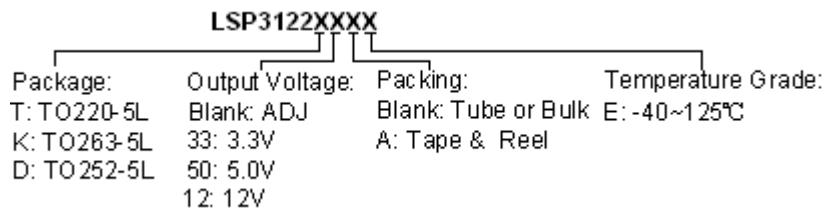

MARKING INFORMATION

(1) TO220-5L

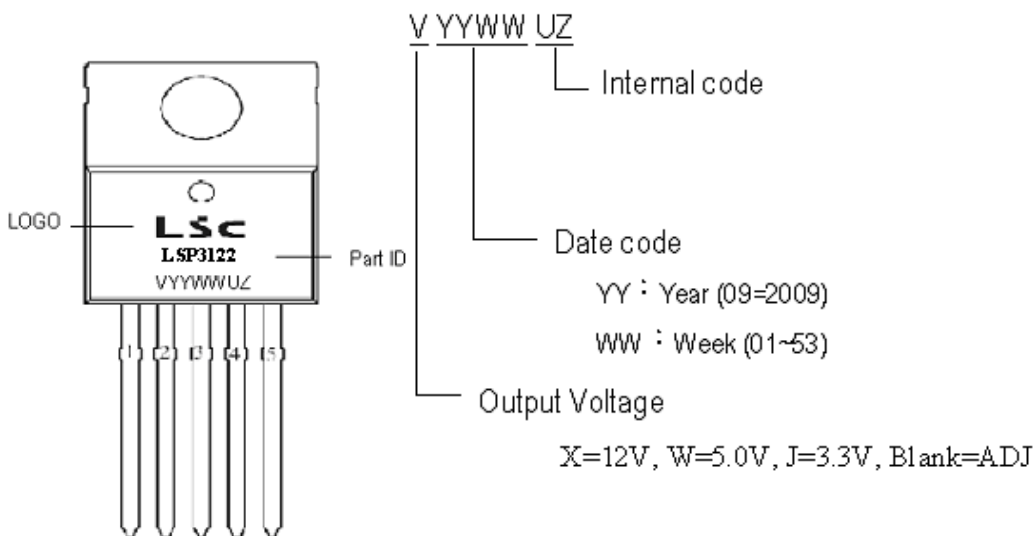

(2) TO263-5L



Liteon Semiconductor Corporation

LSP3122

150KHZ 3A PWM Buck DC/DC Converter

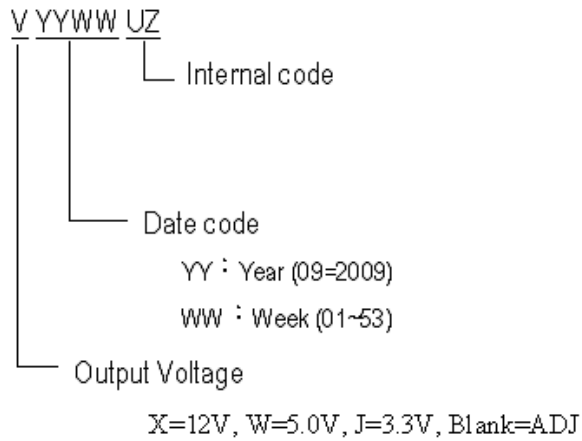
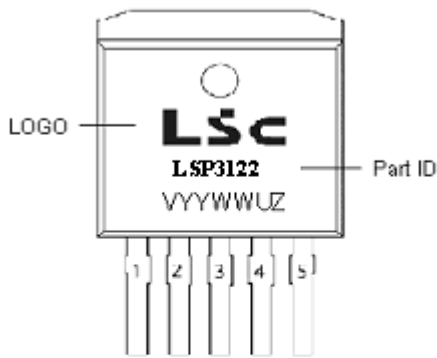

(3) TO252-5L

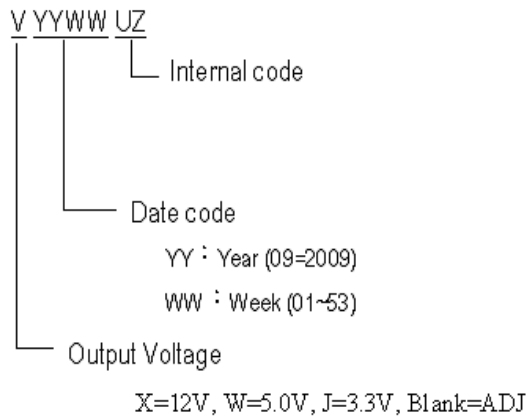
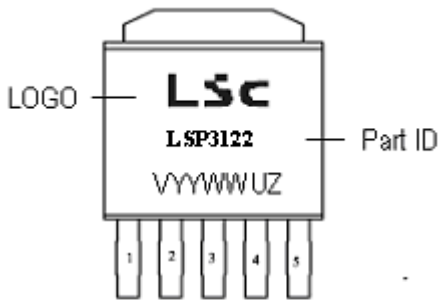

■ PACKAGE INFORMATION

1) TO220-5L

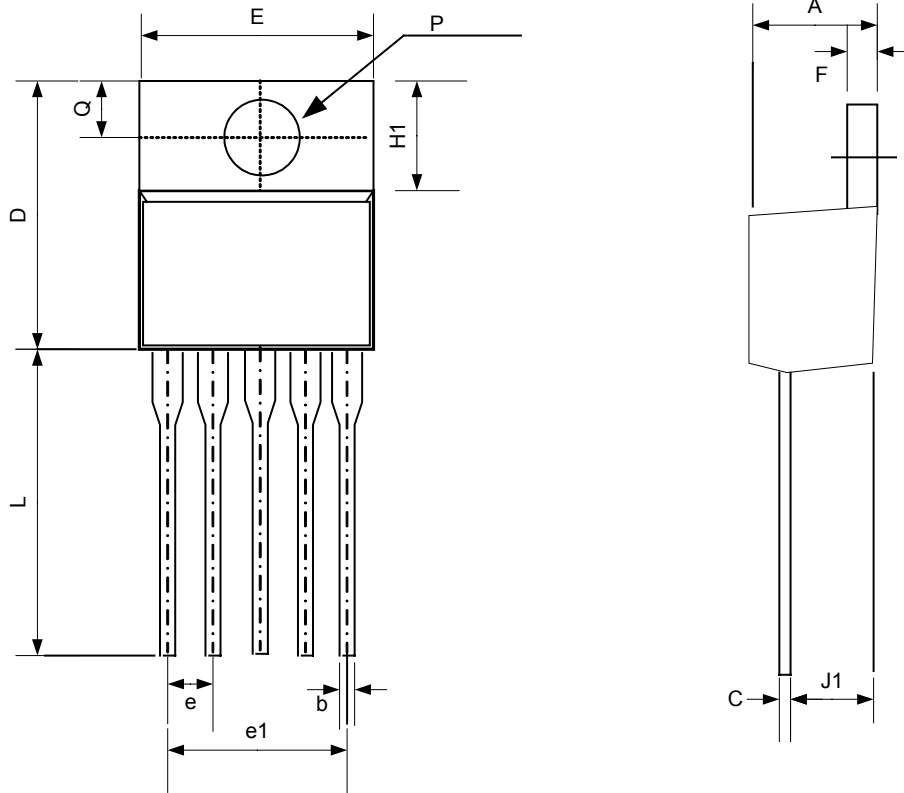

150KHZ 3A PWM Buck DC/DC Converter

Symbol	Dimensions In Millimeters			Dimensions In Inches		
	Min.	Nom.	Max.	Min.	Nom.	Max.
A	4.07	4.45	4.82	0.160	0.175	0.190
b	0.76	0.89	1.02	0.030	0.035	0.040
C	0.36	0.50	0.64	0.014	0.020	0.025
D	14.22	14.86	15.50	0.560	0.585	0.610
E	9.78	10.16	10.54	0.385	0.400	0.415
e	1.57	1.71	1.85	0.062	0.067	0.073
e1	6.68	6.81	6.93	0.263	0.268	0.273
F	1.14	1.27	1.40	0.045	0.050	0.055
H1	5.46	6.16	6.86	0.215	0.243	0.270
J1	2.29	2.74	3.18	0.090	0.108	0.125
L	13.21	13.97	14.73	0.520	0.550	0.580
P	3.68	3.81	3.94	0.145	0.150	0.155
Q	2.54	2.73	2.92	0.100	0.107	0.115

2) TO263-5L

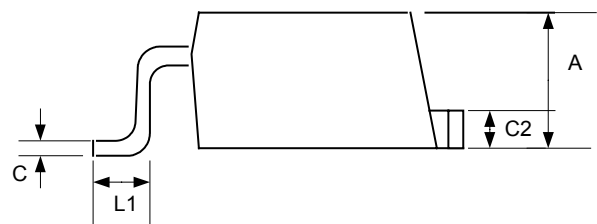
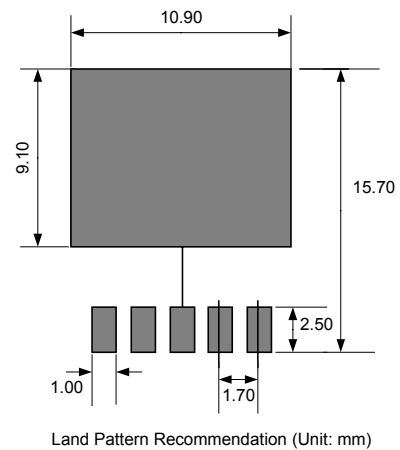
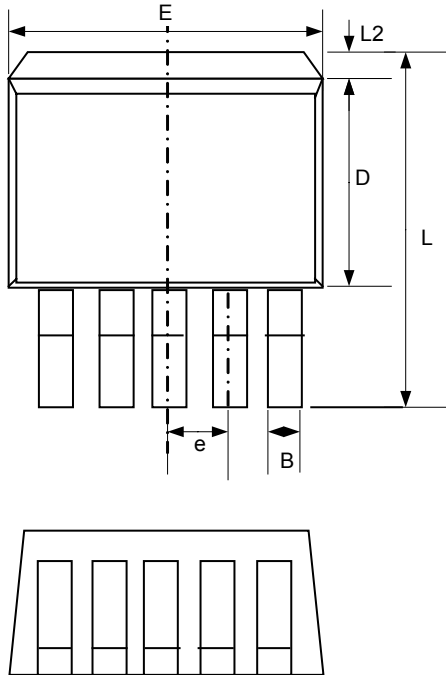

Symbol	Dimensions In Millimeters			Dimensions In Inches		
	Min.	Nom.	Max.	Min.	Nom.	Max.
A	4.07	4.46	4.85	0.163	0.176	0.194
B	0.51	0.84	1.02	0.020	0.033	0.041
C	0.36	0.50	0.74	0.014	0.020	0.030
C2	1.14	1.27	1.65	0.046	0.050	0.066
D	8.20	9.15	9.65	0.328	0.360	0.380
E	9.65	10.16	10.67	0.386	0.400	0.427
e	1.57	1.71	1.85	0.063	0.068	0.074
L	14.45	15.24	15.88	0.578	0.600	0.635
L1	1.78	2.54	2.79	0.071	0.100	0.110
L2			2.92			0.115

(3) TO252-5L

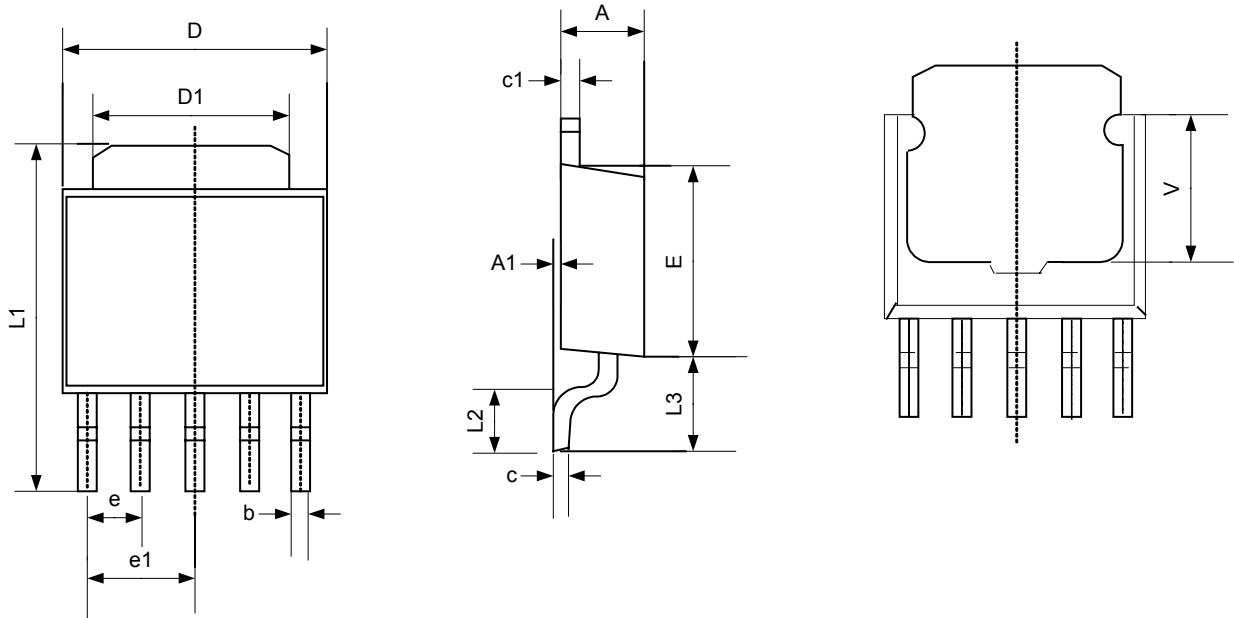

Symbol	Dimensions In Millimeters		Dimensions In Inches	
	Min.	Max.	Min.	Max.
A	2.200	2.400	0.087	0.094
A1	0.000	0.127	0.000	0.005
b	0.400	0.600	0.016	0.024
c	0.430	0.580	0.017	0.023
c1	0.430	0.580	0.017	0.023
D	6.350	6.650	0.250	0.262
D1	5.200	5.400	0.205	0.213
E	5.400	5.700	0.213	0.224
e	1.270TYP.		0.050TYP.	
e1	2.540TYP.		1.000TYP.	
L1	9.500	9.900	0.374	0.390
L2	1.400	1.780	0.055	0.070
L3	2.550	2.900	0.100	0.114
V	3.800REF		0.150REF	