

GENERAL DESCRIPTION

The PT4110 is a high efficiency step-up DC/DC converter designed for driving multiple strings of up to nine series-connected white LED from a single cell Lithium Ion battery. It regulates the output current, ideal for driving light emitting diodes (LED) whose light intensity is proportional to the current passing through them. The external ballast resistor sets the LED current ranging from 5mA to 20mA, which can be easily adjusted using either a DC voltage or a pulse width modulated (PWM) signal alternatively. Its low 300mV feedback voltage reduces power loss and improves efficiency.

The PT4110 has multiple features to protect itself from fault conditions including built-in over voltage protection, cycle-by-cycle current limit, over temperature shutdown, input under voltage control and integrated soft-start.

The PT4110 is available in SOT-89-5 and SOP-8 packages.

FEATURES

- 2.7V to 5.5V Input Voltage Range
- 35V Maximum Step-Up Voltage
- <math><1\mu\text{A}</math> Shutdown Mode
- 1.2MHz Fixed Frequency Operation
- Cycle-By-Cycle Current Limit
- Over Voltage Protection
- Under Voltage Lockout
- Integrated Soft-Start
- Thermal Shutdown
- Frequency Jittering for better EMI performance
- SOT89-5 or SOP8 package

APPLICATIONS

- White LED Power Suppliers
- Flat Screen LCD Bias Suppliers
- Portable Media Players
- GPSs
- General middle-sized LCD backlight

ORDERING INFORMATION

PACKAGE	TEMPERATURE RANGE	ORDERING PART NUMBER	TRANSPORT MEDIA	MARKING
SOT89-5, Pb free	-40°C to 85°C	PT4110E89E	Tape and Reel	PT4110 xxxxxX
SOP8, Pb free	-40°C to 85°C	PT4110ESOP	Tape and Reel	PT4110 xxxxxX

Note:

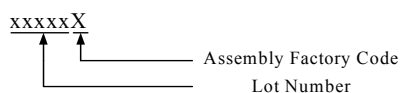

TYPICAL APPLICATION CIRCUIT

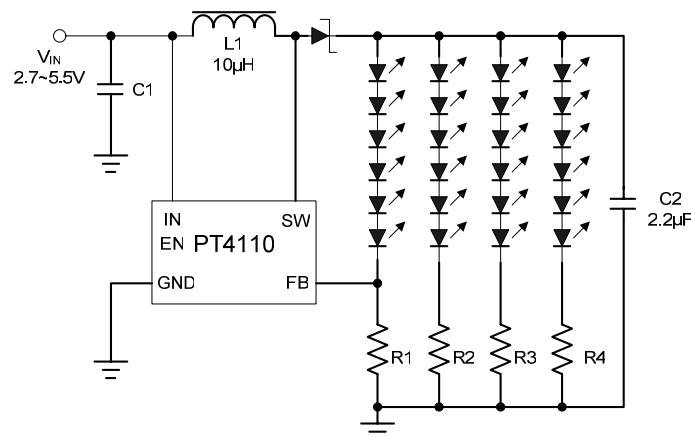

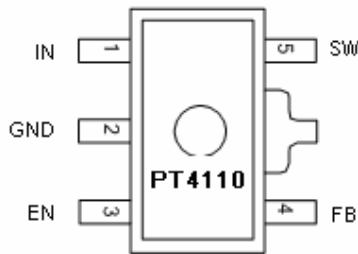
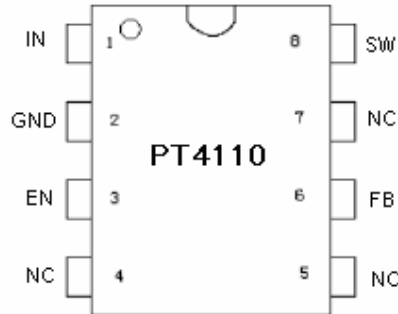
PIN ASSIGNMENT

SOT89-5

SOP8
PIN DESCRIPTIONS

PIN NUMBER		PIN NAME	PIN DESCRIPTION
SOT89-5	SOP8		
1	1	IN	Input Supply Pin. Must be locally bypassed.
2	2	GND	Signal and power ground. Connect directly to ground plane.
3	3	EN	Enable input pin with 500kohm pull-down resistor. The voltage applied to this pin should be either less than 0.4V or more than 1.5V to turn off and on the device respectively. The EN pin can also be used for PWM dimming control. The PWM square wave applied to this pin must be within the range from 100Hz to 100kHz.
4	6	FB	Feedback Input. The PT4110 regulates the voltage across the current sense resistor between FB and GND. Connect a current sense resistor from the bottom of the LED string to GND. Connect the bottom of the LED string to FB. The regulation voltage is 300mV.
5	8	SW	Switch Output. SW is the drain of the internal N-Channel MOSFET switch. Connect the power inductor between SW and the input source, and connect the output rectifier between SW and the output to form the step-up converter.
EP		Exposed PAD	Only for SOT89-5. Internally connected to GND. Mount on board for lower thermal resistance.
	2, 4, 5	NC	Not connection

ABSOLUTE MAXIMUM RATINGS(note1)

SYMBOL	ITEMS	VALUE	UNIT
V_{IN}	Supply Voltage	-0.3~7	V
SW	Drain of the internal power switch	-0.3~45	V
All Other Pins		-0.3~7	V
$\theta_{JA-SOT89-5}$	Thermal resistance for SOT89-5	65	°C/W
$\theta_{JA-SOP-8}$	Thermal resistance for SOP-8	105	°C/W
P_{DMAX}	Power Dissipation SOT89-5(Note 2)	1	W
T_J	Operation Junction Temperature Range	-40 to 150	°C
T_{STG}	Storage Temperature	-55 to 150	°C
	ESD Susceptibility (Note 3)	2	kV

RECOMMENDED OPERATING RANGE

SYMBOL	ITEMS	VALUE	UNIT
V _{IN}	V _{DD} Supply Voltage	0 ~ 5.5	V
T _{OPT}	Operating Temperature	-40 to +85	°C

Note 1: Absolute Maximum Ratings indicate limits beyond which damage to the device may occur. Recommended Operating Range indicates conditions for which the device is functional, but do not guarantee specific performance limits. Electrical Characteristics state DC and AC electrical specifications under particular test conditions which guarantee specific performance limits. This assumes that the device is within the Operating Range. Specifications are not guaranteed for parameters where no limit is given, however, the typical value is a good indication of device performance.

Note 2: The maximum power dissipation must be derated at elevated temperatures and is dictated by T_{JMAX}, θ_{JA}, and the ambient temperature T_A. The maximum allowable power dissipation is P_{DMAX} = (T_{JMAX} - T_A) / θ_{JA} or the number given in Absolute Maximum Ratings, whichever is lower.

Note 3: Human body model, 100pF discharged through a 1.5kΩ resistor.

ELECTRICAL CHARACTERISTICS (Note 4, 5)

V_{IN}=V_{EN}=3.6V, T_A=25°C unless specified otherwise

SYMBOL	ITEMS	CONDITIONS	Min.	Typ.	Max.	UNIT
V _{IN}	Input Voltage		2.7		5.5	V
V _{UVLO}	Under voltage lock out	V _{IN} rising		2.3		V
V _{UVLO, HYS}	UVLO hysteresis	V _{IN} falling		100		mV
Feedback						
V _{FB}	FB Pin Voltage		280	300	320	mV
I _{BIAS}	FB Pin Input Bias Current			0.05	1	μA
Operating Current						
I _{OFF}	Operating Current (Shutdown)	V _{SW-ON} =0V		0.1	1	μA
I _{OP}	Operating Current (Active)			3	5	mA
F _{SW}	Switching Frequency		1.0	1.2	1.5	MHz
D _{MAX}	Maximum Duty Cycle	V _{FB} =0V	90	95		%
Chip Enable						
V _{EN_H}	EN Minimum High Level		1.5			V
V _{EN_L}	EN Maximum Low Level				0.4	V
I _{EN}	EN Input Bias Current	V _{SW-ON} =0V, 5V			1	μA
Output Switch						
R _{ON}	SW On Resistance	V _{IN} = 5V		0.4		Ω
I _{LIMIT}	SW Current Limit		1.2	1.5		A
I _{LEAK}	SW Leakage Current	V _{sw} =5V		0.01	1	μA
Open Circuit Protection						
V _{OV}	Open Circuit Shutdown Threshold			35		V
Soft Start						
t _{SST}	Soft Start Time	V _{IN} Power On		0.8		ms

Note 4: Typical parameters are measured at 25°C and represent the parametric norm.

Note 5: Datasheet min/max specification limits are guaranteed by design, test, or statistical analysis.

SIMPLIFIED BLOCK DIAGRAM

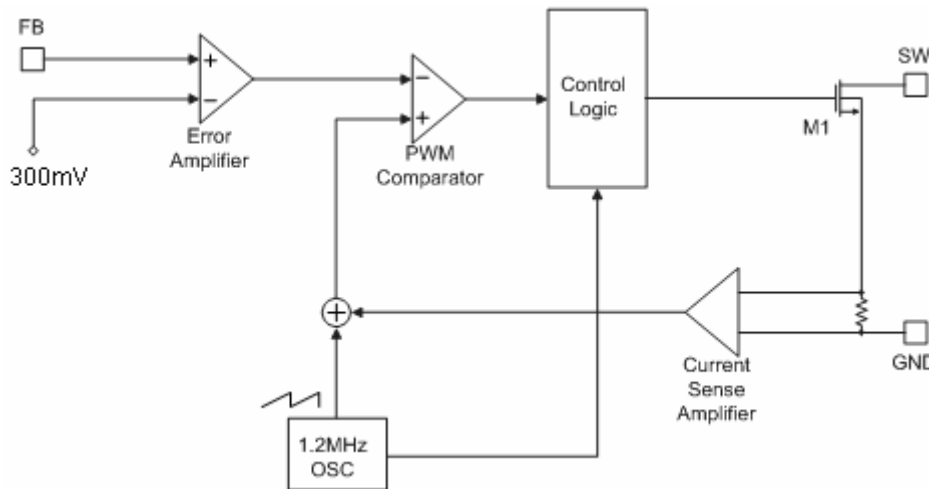

OPERATION DESCRIPTION

The PT4110 uses a constant frequency, peak current mode boost regulator architecture to regulate the series string of white LED. The operation of the PT4110 can be understood by referring to the block diagram. At the start of each oscillator cycle the power MOSFET, M1, is turned on through the control circuitry. To prevent sub-harmonic oscillations at duty cycles greater than 50 percent, a stabilizing ramp is added to the output of the current sense amplifier and the result is fed into the positive input of the PWM comparator. When this voltage equals the output voltage of the error amplifier the power MOSFET is turned off. The voltage at the output of the error amplifier is an amplified version of the difference between the 300mV reference voltage and the feedback voltage. In this way the peak current level keeps the output in regulation. If the feedback voltage starts to drop, the output of the error amplifier

increases. This results in more current flowing through the power MOSFET, thus increasing the power delivered to the output.

The PT4110 can be used to drive multiple strings of white LED as shown in figure “typical application”. The brightness of each LED in such kind of connection will almost be the same provided that the number of series-connected LED in each string is equal and each string is terminated with a well-matched ballast resistor. Otherwise the differential current among strings will be huge enough to cause damage to LED permanently.

To protect the step-up converter when the load is open, or the output voltage becomes excessive for any reason, the PT4110 features a dedicated open LED protection. Onset the output voltage exceeds 35V when the output is open circuit, the step-up converter switches off immediately and won't be enabled until restart the chip.

TYPICAL PERFORMANCE CHARACTERISTICS

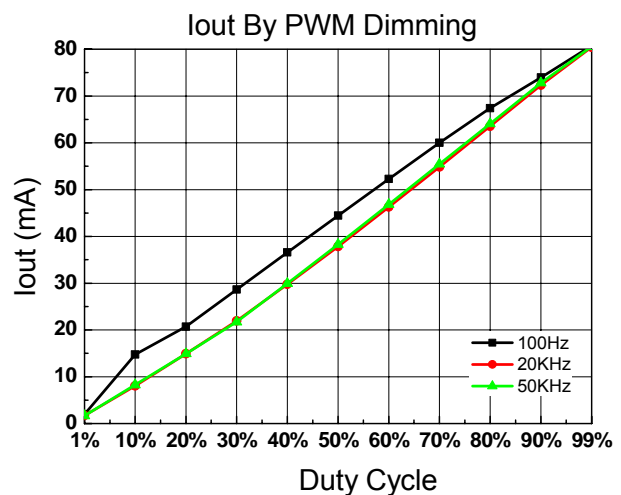
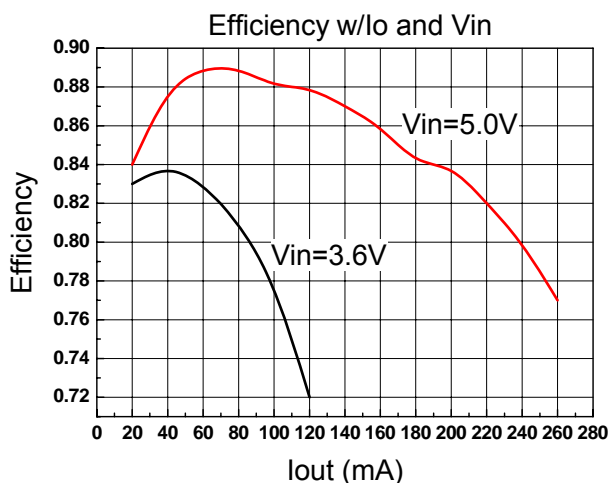

APPLICATION INFORMATION

Setting the LED current

The LED current is controlled by the feedback resistor. The feedback reference is 300mV. The LED current is $300\text{mV}/R_{\text{FB}}$. In order to have accuracy LED current, precision resistor is preferred. (1% is recommended).

Selecting the inductor

Choose an inductor that does not saturate under the worst-case load transient and startup conditions. A good rule for determining the inductance is to allow the peak-to-peak ripple current to be approximately 30% to 50% of the maximum input current. Make sure that the peak inductor current is below 1.2A to prevent loss of regulation due to the current limit. For most of the applications of the PT4110, it is recommended to use an inductor of 10uH.

Selecting the Input Capacitor

An input capacitor is required to supply the AC ripple current to the inductor, while limiting noise at the input source. A low ESR capacitor is required to keep the noise at the IC to a minimum. Ceramic capacitors are preferred, but tantalum or low-ESR electrolytic capacitors may also suffice.

Use an input capacitor value greater than 22μF. The capacitor can be electrolytic, tantalum or ceramic. However since it absorbs the input switching current it requires an adequate ripple current rating. Use a capacitor with RMS current rating greater than the inductor ripple current.

Selecting the Output Capacitor

The output capacitor is required to maintain the DC output voltage. Low ESR capacitors are preferred to keep the output voltage ripple to a minimum. The characteristic of the output capacitor also affects the stability of the regulation control system. 2.2uF ceramic, tantalum, or low ESR electrolytic capacitors are recommended.

Selecting the Diode

The output rectifier diode supplies current to the inductor when the internal MOSFET is off. To reduce losses due to diode forward voltage and recovery time, use a Schottky diode. Choose a diode whose maximum reverse voltage rating is greater than the maximum output voltage. The rated average forward current needs to be equal to or greater than the load current.

Open Circuit Protection

Open circuit protection will shut off the PT4110 if the output voltage goes too high. In some cases an LED

may fail, which will result in the feedback voltage always being zero. The PT4110 will then switch at its maximum duty cycle boosting the output voltage higher and higher. The PT4110 detects the voltage of SW pin. The output of PT4110 is equal high level of SW pin subtracting the forward voltage of the Schottky diode. If the SW pin exceeds 36V for several periods, the T4110 will shut down. The part will not switch again until the power is recycled.

Dimming Control

There are two different types of dimming control circuits:

1. Using a DC Voltage

For some applications, the preferred method of brightness control is a variable DC voltage to adjust the LED current. The dimming control using a DC voltage is shown as below. As the DC voltage increases, the voltage drop on R2 increases and the voltage drop on R1 decreases. Thus, the LED current decreases. The selection of R2 and R3 will make the current from the variable DC source much smaller than the LED current and much larger than the FB pin bias current.

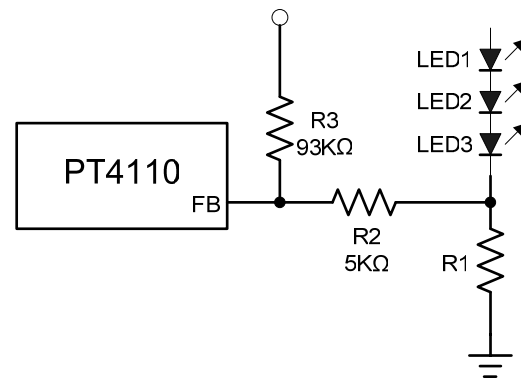

2. Using a PWM Signal to EN Pin

With the PWM signal applied to the EN pin, the reference of PT4110 is changed with the duty cycle of the PWM signal. The LEDs operate at either zero or full current. The average LED current increases proportionally with the duty cycle of the PWM signal. A 0% duty cycle will turn off the PT4110 and corresponds to zero LED current. A 100% duty cycle corresponds to full current. The typical frequency range of the PWM signal should be higher than 20 kHz to avoid the audio noise.

Typical application circuits:

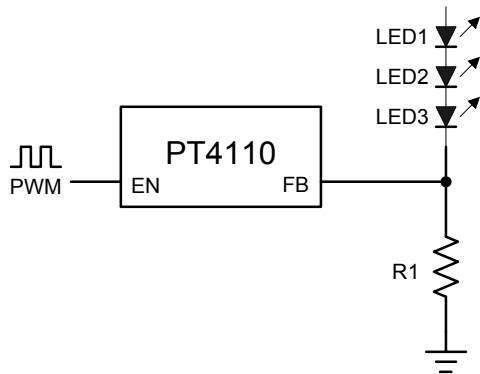

Start-up and Inrush Current

The PT4110 has internal soft start to limit the amount of current through VIN at startup and to also limit the amount of overshoot on the output. The soft start is realized by gradually increasing the current limit during start-up. The current limit is increased by a fourth every 200 μ S giving a total soft start time of around 800 μ S.

Board Layout Consideration

As with all switching regulators, careful attention must be paid to the PCB board layout and component placement. High frequency switching regulators require very careful layout for stable operation and low noise. To maximize efficiency, switch rise and fall times are made as short as possible. To prevent electromagnetic interference (EMI) problems, proper layout of the high frequency switching path is essential. The voltage signal of the SW pin has sharp rise and fall edges. Minimize the length and area of all traces connected to the SW pin and always use a ground plane under the switching regulator to minimize interplane coupling. In addition, the ground connection for the feedback resistor R1 should be tied directly to the GND pin and not shared with any other component, ensuring a clean, noise-free connection.

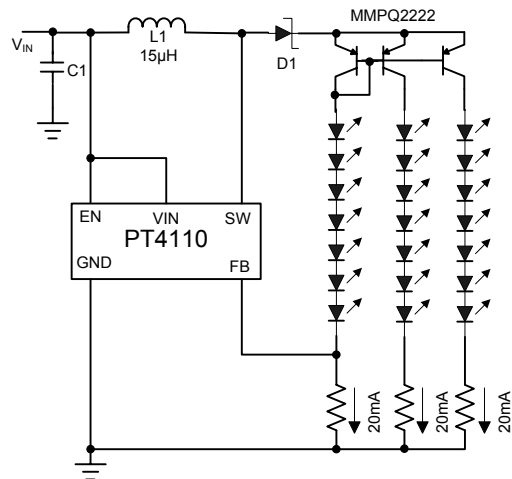
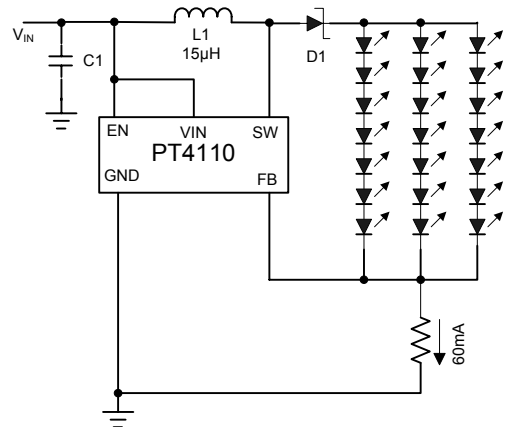
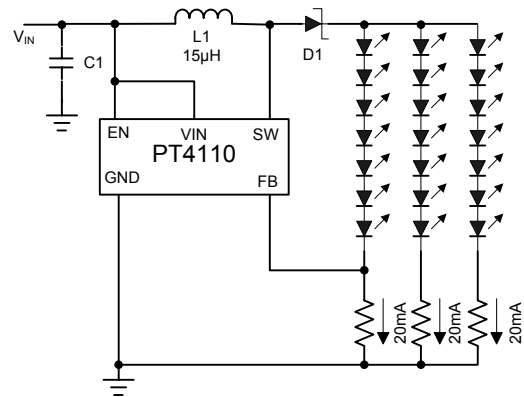

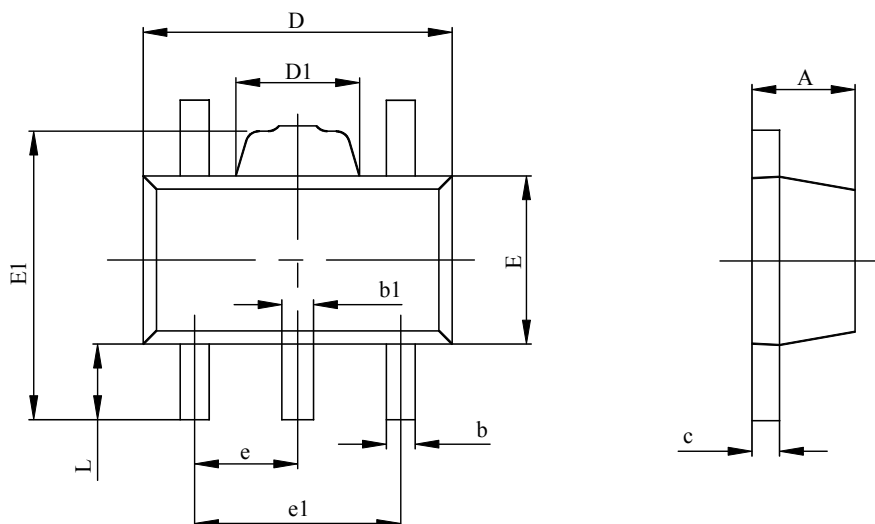
PACKAGE INFORMATION
SOT89-5

SYMBOL	MILLIMETERS		INCHES	
	MIN	MAX	MIN	MAX
A	1.400	1.600	0.055	0.063
b	0.320	0.520	0.013	0.020
b1	0.360	0.560	0.014	0.022
c	0.350	0.440	0.014	0.017
D	4.400	4.600	0.173	0.181
D1	1.400	1.800	0.055	0.071
E	2.300	2.600	0.091	0.102
E1	3.940	4.250	0.155	0.167
e	1.500 TYP.		0.060 TYP.	
e1	2.900	3.100	0.114	0.122
L	0.900	1.100	0.035	0.043

PACKAGE INFORMATION

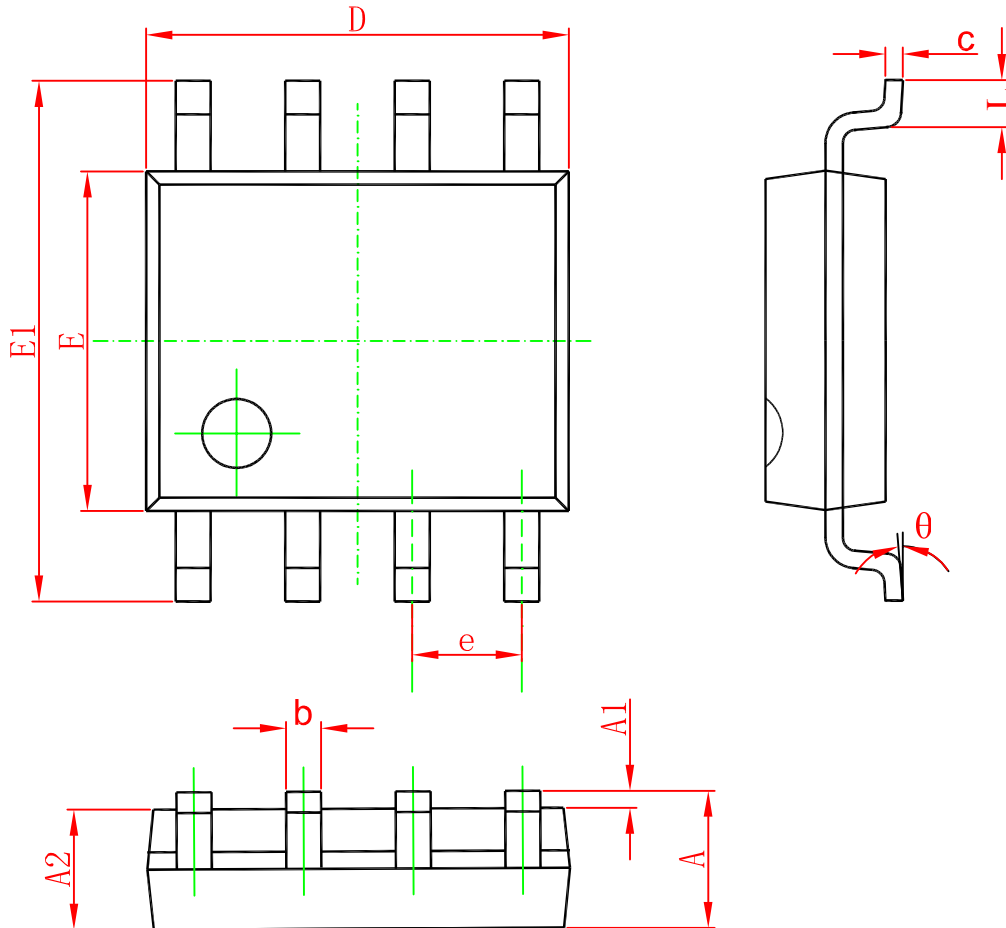
SOP-8

SYMBOL	DIMENSIONS IN MILLIMETERS		DIMENSIONS IN INCH	
	MIN	MAX	MIN	MAX
A	1.350	1.750	0.053	0.069
A1	0.100	0.250	0.004	0.010
A2	1.350	1.550	0.053	0.061
b	0.330	0.510	0.013	0.020
c	0.170	0.250	0.006	0.010
D	4.700	5.100	0.185	0.200
E	3.800	4.000	0.150	0.157
E1	5.800	6.200	0.228	0.244
e	1.270(BSC)		0.050(BSC)	
L	0.400	1.270	0.016	0.050
θ	0°	8°	0°	8°