

## MSD415 Microstepping Drive

### Introduction

MSD415 is a very small size microstepping drive based on most advanced technology in the world today. It is suitable for driving any 2-phase and 4-phase hybrid stepper motors. By using advanced bipolar constant-current chopping technique, it can output more speed and power from the same motor, compared with traditional technologies such as L/R drives.

### Feature

- Supply voltage up to +40VDC, output current up to 1.5A peak
- Inaudible 20KHz chopping frequency
- TTL compatible and optically isolated input signals
- Automatic idle-current reduction
- Mixed-decay current control for less motor heating
- 7 selectable resolutions up to 12,800 steps/rev
- Microstep resolution can be changed on the fly (optional)
- Suitable for 2-phase and 4-phase stepper motors
- Reverse polarity protection
- Small size (86x55x20.5mm)



### Applications

It is suitable for a wide range of stepping motors of NEMA 16 and 23 and usable for various kinds of machines such as X-Y tables, labeling machines, laser cutters, engraving machines and pick-place devices. It is particularly useful for the applications where low vibration, high speed and high precision are desired.

### Electronical Specification (Tj = 25°C/77°F)

Parameters	MSD415			
	Unit	Min	Typical	Max
Output Current	Amps	0.21	-	1.5
Supply voltage (DC)	VDC	+15	-	+40
Logic signal current	mA	7	10	16
Pulse input frequency	KHz	0	-	300
Isolation resistance	MΩ	500	-	-

## Operating Environment and Other Specifications

<b>Cooling</b>	Natural Cooling or Forced cooling	
<b>Operating Environment</b>	<i>Environment</i>	Avoid dust, oil fog and corrosive gases
	<i>Ambient Temperature</i>	0°C ~ 50°C
	<i>Humidity</i>	40%RH—90%RH
	<i>Operational Temperature</i>	70 °C Max.
	<i>Vibration</i>	5.9m/s <sup>2</sup> Max
<b>Storage Temperature</b>	-20°C ~ 65°C	
<b>Weight</b>	Approx. 150g (5.3oz)	

## Mechanical Specifications (in mm, 1 inch = 25.4 mm)

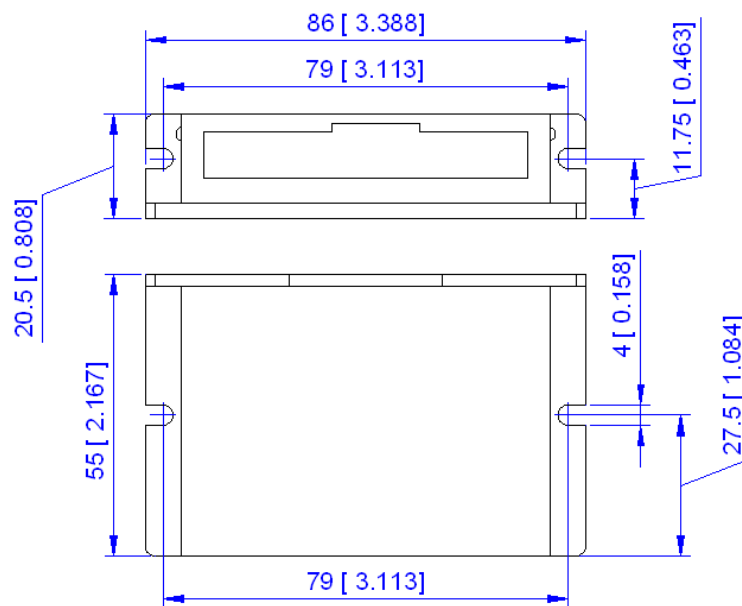

\*\*\*\* Recommend to use side mounting for better heat dissipation

## Pin Assignment and Description

The MSD415 stepper drive has two connectors, connector P1 for control signals connections, and connector P2 for power and motor connections. The following tables are brief descriptions of the two connectors on MSD415 stepper drive. For more details, please refer to our **MSD415 Stepper Drive Manual Version 2.0**

**Connector P1 configurations**

Signal	Functions
PUL	<b>Pulse signal:</b> This input represents pulse signal, effective for each rising edge; 4-5V when PUL-HIGH, 0-0.5V when PUL-LOW. For reliable response, pulse width should be longer than 1.5µs. Series connect resistors for current-limiting when +12V or +24V used.
DIR	<b>Direction signal:</b> HIGH/LOW level signal, correlative to motor rotation direction. For reliable response, DIR must be ahead of PUL by 5µs at least. 4-5V when DIR- HIGH, 0-0.5V when DIR-LOW. Motor rotation direction also depends upon the connection of the motor windings, exchange any motor phase can reverse motor rotation direction.
OPTO	Opto-coupler power supply and the typical voltage is +5V.
ENA	<b>Enable signal:</b> This signal is used for enabling/disabling the drive. High level for enabling the drive and low level for disabling the drive. Usually left unconnected (enabled).

**Connector P2 Configurations**

Signal	Functions
GND	DC power ground
+V	DC power supply, +18VDC ~ +40VDC, including voltage fluctuation and EMF voltage.
A+, A-	Motor Phase A
B+, B-	Motor Phase B

**Setting Drive Output Current and Microstep Resolution**

This drive uses a 6-bit DIP switch to set microstep resolution and motor operating current, as shown below:

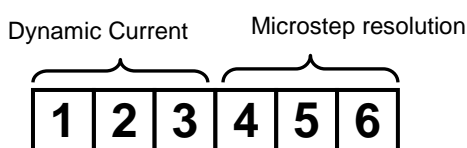

**Microstep Resolution Selection**

Microstep resolution is set by SW4, SW5 and SW6 of the DIP switch as shown in the following table:

Microsteps / Full Step	Microsteps/rev. (for 1.8° motor)	SW4/MS0	SW5/MS1	SW6/MS2
1	200	ON	ON	ON
2	400	OFF	ON	ON
4	800	ON	OFF	ON
8	1600	OFF	OFF	ON
16	3200	ON	ON	OFF
32	6400	OFF	ON	OFF
64	12800	ON	OFF	OFF

### **Current Setting**

The first three bits (SW1, 2, 3) of the DIP switch are used to set the dynamic current. Select a setting closest to your motor's required current.

**Dynamic Current Setting:**

Peak current	SW1	SW2	SW3
0.21A	OFF	ON	ON
0.42A	ON	OFF	ON
0.63A	OFF	OFF	ON
0.84A	ON	ON	OFF
1.05A	OFF	ON	OFF
1.26A	ON	OFF	OFF
1.50A	OFF	OFF	OFF

**Notes:** Due to motor inductance, the actual current in the coil may be smaller than the dynamic current setting, particularly under high speed condition.

**Standstill Current**

The standstill current of MSD415 will be automatically reduced to 60% of the selected dynamic current setting one second after the last pulse. Theoretically, this will reduce motor heating to 36% (due to  $P=I^2 \cdot R$ ) of the original value. If the application needs a different standstill current, please contact Motion Control Products Ltd for more advice.

### **Typical Connections**

A complete stepping system should include stepping motor, stepping driver, power supply and controller (pulse generator). The following figures on page 5 are two typical connections of MSD415 stepper drive.

(a) Connect to single-ended control signal

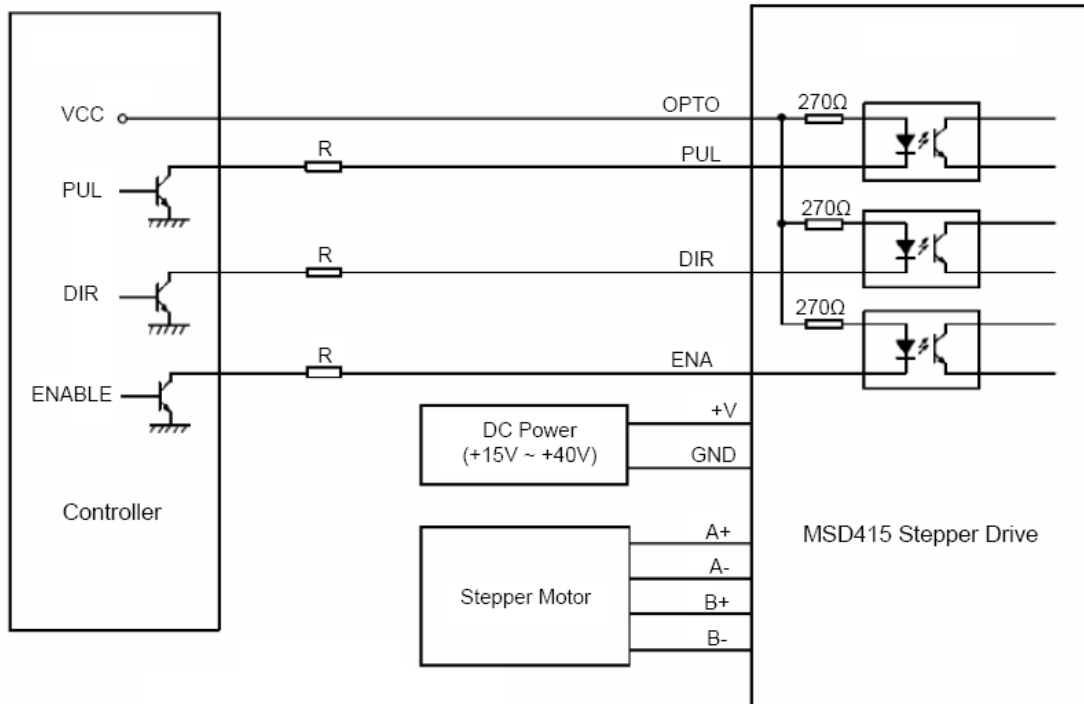

R=0 if VCC=5V;  
 R=1K (Power > 0.125W) if VCC=12V;  
 R=2K (Power > 0.125W) if VCC=24V;  
 R must be connected to control signal terminal.

(b) Connect to differential control signal

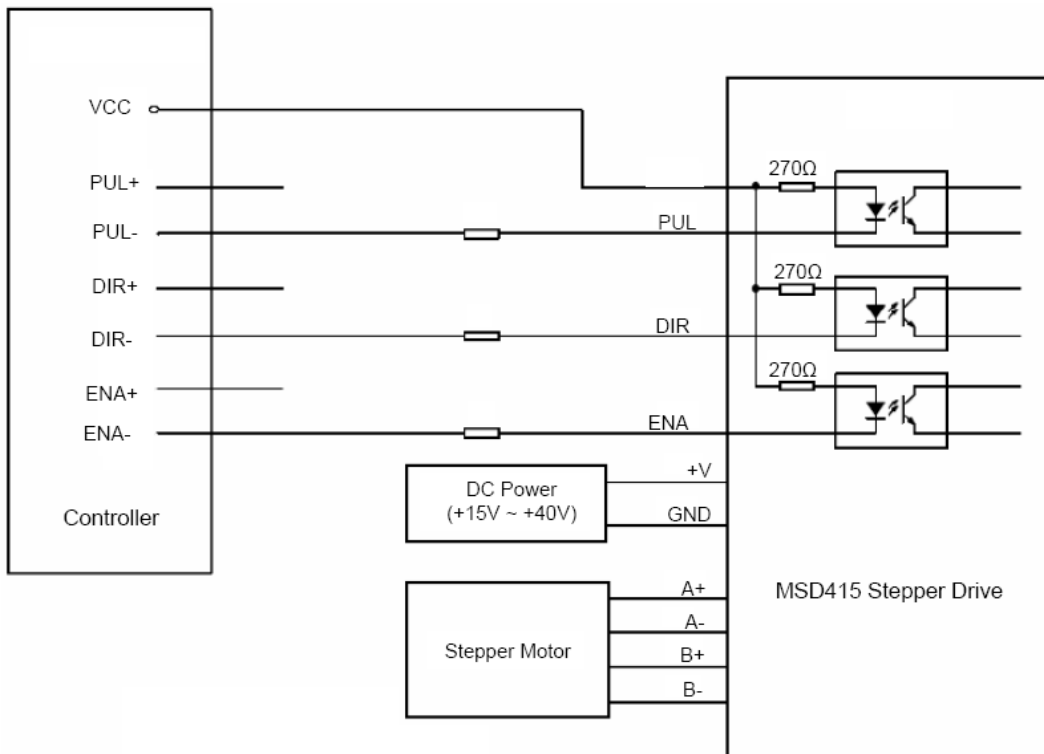

R=0 if VCC=5V;  
 R=1K (Power > 0.125W) if VCC=12V;  
 R=2K (Power > 0.125W) if VCC=24V;  
 R must be connected to control signal terminal.