

GENERAL DESCRIPTION

The PT1203 is a monolithic pulse-width-modulated (PWM) synchronous step-down switch mode regulator with two internal power MOSFETs. It achieves 2A continuous output current over a wide input supply range with excellent load and line regulation. Current mode operation provides fast transient response and eases loop stabilization. Fault condition protection includes cycle-by-cycle current limit and thermal shutdown.

The PT1203 requires a minimum number of external components, available in SOP-8 and ESOP-8 package.

FEATURES

- 2A Output Current
- 0.13Ω Internal Power MOSFET Switch
- Stable with Low ESR Output Ceramic Capacitors
- Up to 93% Efficiency
- Fixed 350KHz Frequency
- Thermal Shutdown
- Cycle-by-Cycle Over Current Protection
- Wide 4.75V to 18V Operating Input Range
- Output Adjustable from 0.923V to 15V
- Available in 8-Pin SOP8 and ESOP8 Packages

APPLICATION

- PC Monitors
- LCD TV
- Distributed Power Systems
- Network Systems
- FPGA, DSP, ASIC Power Supplies
- Notebook Computers

ORDERING INFORMATION

PACKAGE	TEMPERATURE RANGE	ORDERING PART NUMBER	TRANSPORT MEDIA	MARKING
SOP-8	-40°C to 85°C	PT1203ESOH	Tape and Reel 2500 units	PT1203 xxxxxX
ESOP-8	-40°C to 85°C	PT1203EESH	Tape and Reel 2500 units	PT1203 xxxxxX

Note:

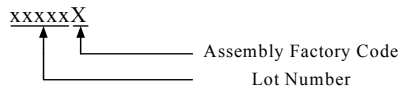

TYPICAL APPLICATION CIRCUIT

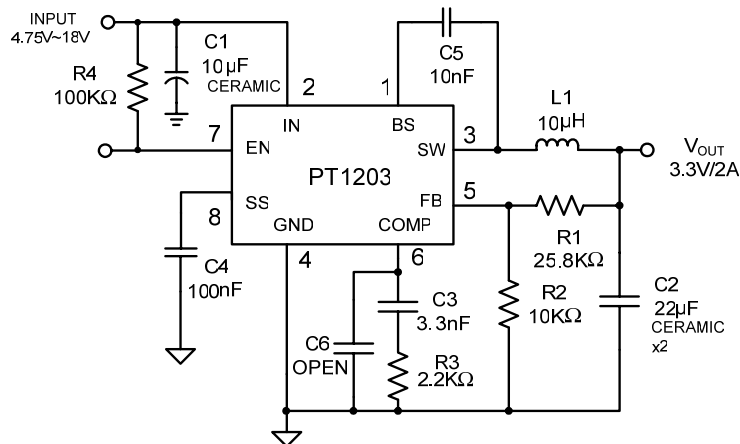
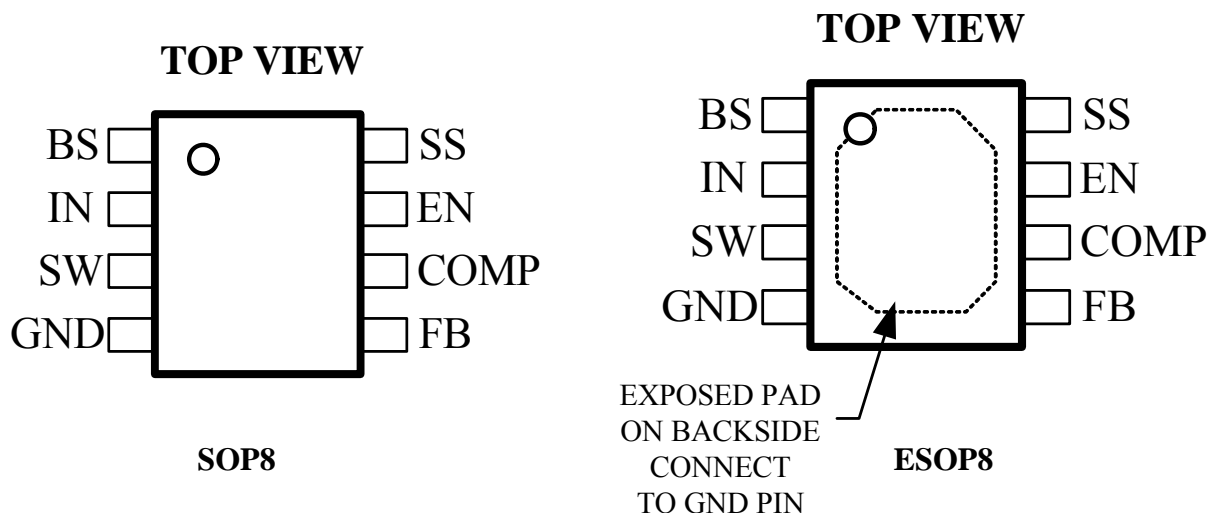

Figure1 —PT1203 Typical application circuit

PIN ASSIGNMENT



PIN DESCRIPTIONS

SOP8 PIN No.	PIN NAMES	DESCRIPTION
1	BS	High-Side Gate Driver Boost Input. BS supplies the drive for the high-side N-channel MOSFET switch. Connect a 0.01uF or greater capacitor from SW to BS to power the high side switch.
2	IN	Supply Voltage. The PT1203 operates from a +4.75V to +18V unregulated input. C1 is needed to prevent large voltage spikes from appearing at the input.
3	SW	Power Switching Output. This PIN is connected to IN through M1 or to GND through M2.
4	GND	Ground
5	FB	Feedback Input. FB senses the output voltage through an external resistive divider which is connected from the output to GND.
6	COMP	Compensation Node. COMP compensates the control loop by connecting a serial RC network to ground. In some cases, an additional capacitor from COMP to GND is required.
7	EN	Enable Input. EN is digital input that turns the regulator on or off. Drive EN high to turn on the regulator, drive it low to turn it off. Pull up to IN with 100kΩ resistor for automatic startup.
8	SS	Soft-Start. Connect a capacitor from SS to GND to program the soft-start period. Leave it open if unused.

ABSOLUTE MAXIMUM RATINGS (Note 1)

SYMBOL	ITEMS	VALUE	UNIT
IN	Supply Voltage	-0.3~24	V
SW	Switch Node voltage	-0.3~24	V
BS	Bootstrap Voltage	$V_{sw}-0.3\sim V_{sw}+6$	V
FB	Feedback voltage	-0.3~6	V
EN	Enable/UVLO voltage	-0.3~6	V
COMP	Comp voltage	-0.3~6	V
TSTG	Storage temperature range	-65~+150	°C

RECOMMENDED OPERATING RANGE

SYMBOL	ITEMS	VALUE	UNIT
VIN	Supply voltage	4.75~18	V
TOPT	Operating temperature	-40~+85	°C

Note 1: Absolute Maximum Ratings indicate limits beyond which damage to the device may occur. Recommended Operating Range indicates conditions for which the device is functional, but do not guarantee specific performance limits. Electrical Characteristics state DC and AC electrical specifications under particular test conditions which guarantee specific performance limits. This assumes that the device is within the Operating Range. Specifications are not guaranteed for parameters where no limit is given, however, the typical value is a good indication of device performance.

ELECTRICAL CHARACTERISTICS

The following specifications apply for $V_{IN}=12V$, $V_{OUT}=3.3V$, load=0.5A, $T_A=25^\circ C$, unless specified otherwise.

SYMBOL	ITEMS	CONDITIONS	MIN.	TYP.	MAX.	UNIT
I _q	Supply current	EN=2V; V _{fb} =1v		1.5	2.0	mA
V _{fb}	Feedback voltage		0.900	0.923	0.946	V
A _v	Error amplifier voltage gain			400		V/V
G _{ea}	Error amplifier trans-conductance	$\Delta I_{comp}=\pm 10\mu A$		800		$\mu A/V$
R _{dson1}	High side switch on resistance			0.13		Ω
R _{dson2}	Low side switch on resistance			0.13		Ω
I _{pd}	Shutdown supply current	V _{en} = 0V		13	20	μA
I _{leakage}	High side switch leakage current ⁽²⁾	V _{en} =0V; V _{sw} =0V		0	10	μA
I _{clh}	High side Switch Current limit ⁽²⁾		2.4	3.5		A
I _{cll}	Low side Switch Current limit ⁽²⁾			1.0		A
G _{comp}	COMP to Current sense trans-conductance			3.2		A/V
F _{osc1}	Oscillation frequency			350		kHz

ELECTRICAL CHARACTERISTICS (Continued)

SYMBOL	ITEMS	CONDITIONS	MIN.	TYP.	MAX.	UNIT
Fosc2	Short circuit oscillation frequency	Vfb=0.3V		90		kHz
Dmax	Maximum duty cycle	Vfb=0.8V		90		%
Ven	EN threshold voltage		1.1	1.5	2.0	V
Ven_hyst	EN threshold Voltage Hysteresis			0.2		V
TSD	Thermal shutdown			160		°C

Note 2: Guaranteed by design.

SIMPLIFIED BLOCK DIAGRAM

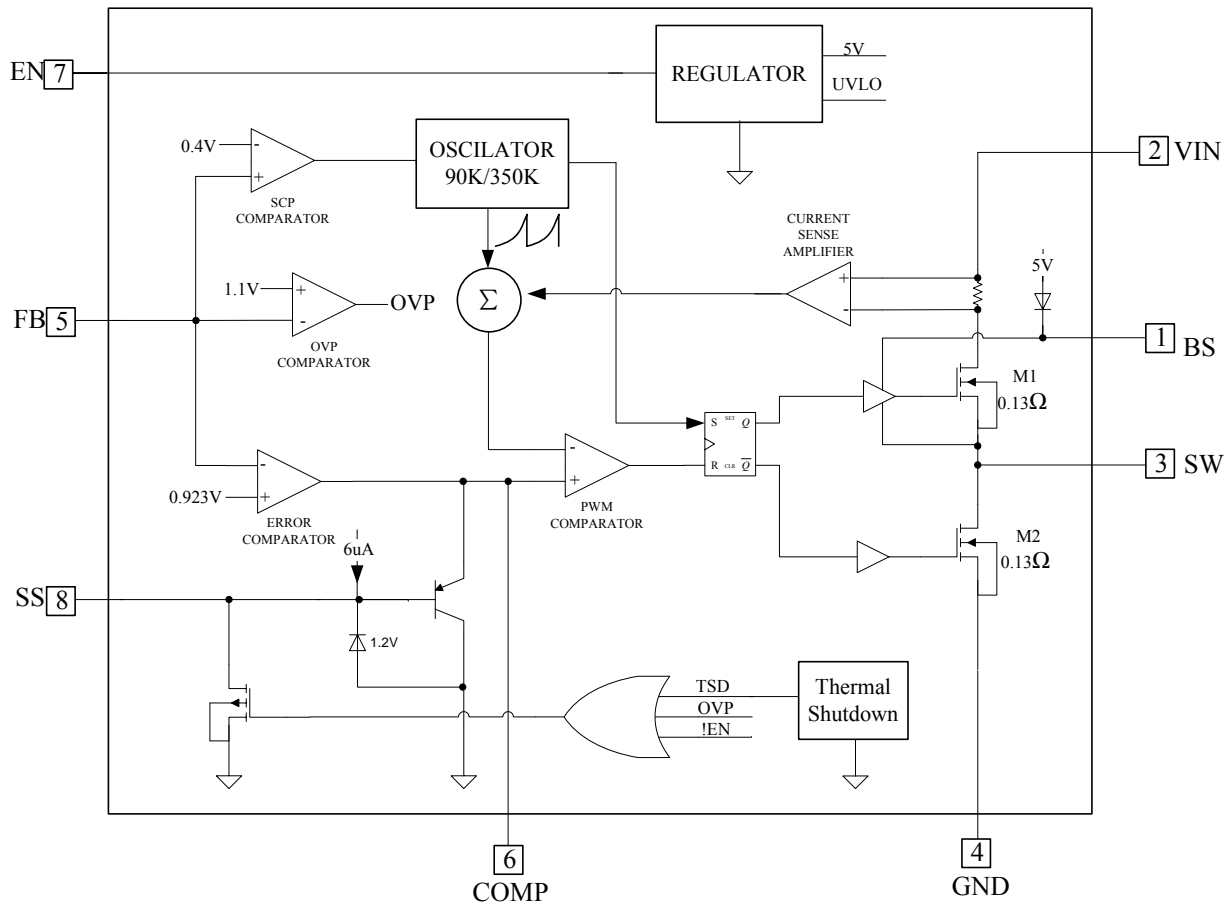

Figure 2—Functional Block Diagram

OPERATION DESCRIPTION

The PT1203 is a synchronous rectified current mode step-down regulator. It regulates input voltage from 4.75V to 18V down to a voltage as low as 0.923V, and supplies up to 2A of load current.

On the rising edge of internal oscillator, the Low-Side MOSFET will be turned off and the High-Side MOSFET will be turned on if the PWM comparator output is low. The output voltage is measured at FB pin through a resistive voltage divider and amplified through the internal error amplifier, the voltage at the COMP pin is compared with the switch current. As the

switch current ramp up, the PWM comparator will output high, the High-Side MOSFET will be turned off and the Low-Side MOSFET will be turned on until the next rising edge of the internal oscillator.

When the output voltage exceeds 20% of the nominal regulated voltage, the Over-Voltage comparator will be tripped and turn off the High-Side MOSFET by discharging the SS pin to GND.

When the FB voltage is less than 0.4V, the frequency of the internal oscillator will be set to 90KHz to decrease the short circuit current.

APPLICATION INFORMATION

Setting the Output Voltage

The output voltage is set using a resistive voltage divider from the output to FB pin. The voltage divider divides the output voltage down to the feedback voltage by the ratio:

$$V_{FB} = V_{OUT} \frac{R2}{R1 + R2}, \text{ where the } V_{FB} \text{ is the}$$

feedback voltage and V_{OUT} is the output voltage.

Thus the output voltage is :

$$V_{OUT} = 0.923 * \frac{R1 + R2}{R2}.$$

The typical value of R2 is 10kΩ.

Inductor Selection

The inductor is required to supply constant current to the output load while being driven by the switched input voltage. A larger value inductor will result in less ripple current that will result in lower output ripple voltage. A good rule for choosing the inductor is to allow the peak-to-peak ripple current in the inductor to be approximately 30% of the maximum switch current limit. The inductance value can be

calculated by: $L = \frac{V_{OUT}}{f_{sw} * \Delta I_L} * \left(1 - \frac{V_{OUT}}{V_{IN}}\right)$, where

V_{OUT} is the output voltage, V_{IN} is the input

voltage, f_{sw} is the switching frequency, and ΔI_L

is the peak-to-peak inductor ripple current. Choose an inductor that will not saturate under the maximum inductor peak current. The peak inductor current can be calculated by:

$$I_{LP} = I_{LOAD} + \frac{V_{OUT}}{2 * f_{sw} * L} * \left(1 - \frac{V_{OUT}}{V_{IN}}\right), \text{ where}$$

I_{LOAD} is the load current.

Input Capacitor Selection

The input current to the converter is discontinuous, therefore a capacitor is required to supply the AC current to the converter while maintaining the DC input voltage. Use the low ESR capacitors for the best performance. Ceramic capacitors are preferred, but tantalum or low-ESR electrolytic capacitors may also suffice.

Since the input capacitor absorbs the input switching current it requires an adequate ripple current rating. The RMS current in the input capacitor can be estimated by:

Synchronous Step-Down Converter

$$I_{C_{IN}} = I_{LOAD} * \sqrt{\frac{V_{OUT}}{V_{IN}} * \left(1 - \frac{V_{OUT}}{V_{IN}}\right)}. \text{ Choose the}$$

input capacitor whose RMS current rating greater than the calculated value.

Output Capacitor Selection

The output capacitor is required to maintain the DC output voltage. Ceramic, tantalum, or low ESR electrolytic capacitors are recommended. Low ESR capacitors are preferred to keep the output voltage ripple low. The output voltage ripple can be estimated by:

$$\Delta V_{OUT} = \frac{V_{OUT}}{f_{SW} * L} * \left(1 - \frac{V_{OUT}}{V_{IN}}\right) * \left(R_{ESR} + \frac{1}{8 * f_{SW} * C_2}\right)$$

, where C_2 is the output capacitance value and R_{ESR} is the equivalent series resistance value of the output capacitor.

Compensation Components Selection

The system stability and transient response are controlled through the COMP pin. A series capacitor-resistor combination sets a pole-zero combination to control the characteristics the system. The DC gain of the voltage feedback loop is:

$$A_{DC} = R_{LOAD} * G_{CS} * A_{EA} * \frac{V_{FB}}{V_{OUT}}, \text{ where } A_{EA} \text{ is}$$

the error amplifier voltage gain, G_{CS} is the current sense transconductance and R_{LOAD} is the load resistor value.

The voltage feedback loop has two poles of importance. One is due to the compensation capacitor and the output resistor of the error amplifier, and the other is due to the output capacitor

and the load resistor, these poles are located at:

$$f_{P1} = \frac{G_{EA}}{2\pi * C_3 * A_{EA}}, \text{ where } G_{EA} \text{ is the}$$

$$f_{P2} = \frac{1}{2\pi * C_2 * R_{LOAD}}$$

error amplifier transconductance.

The system has one zero of importance, due to the compensation capacitor (C3) and the compensation resistor (R3). This zero is located at:

$$f_{Z1} = \frac{1}{2\pi * C_3 * R_3}$$

The system may have another zero of importance, if the output capacitor has a large capacitance and/or a high ESR value. The zero due to the ESR and capacitance of the output capacitor, is located at:

$$f_{ESR} = \frac{1}{2\pi * C_2 * R_{ESR}}, \text{ in this case, a third pole}$$

set by the compensation capacitor (C6) and the compensation resistor (R3) is used to compensate the effect of the ESR zero on the loop gain. The pole is located at:

$$f_{P3} = \frac{1}{2\pi * C_6 * R_3}$$

The goal of compensation is to shape the converter transfer function to get the desired loop gain. Lower crossover frequencies result in slower load transient and line responses, while higher crossover frequencies could cause system instability. A good rule of thumb is to set the crossover frequency blow one-tenth of the switching frequency.

The following procedure can be used to optimize the compensation components.

1. Choose the compensation resistor (R3) to set the desired crossover frequency.

$$R3 = \frac{2\pi * C_2 * f_C * V_{OUT}}{G_{EA} * G_{CS} * V_{FB}}, \text{ where } f_C \text{ is the}$$

desired crossover frequency which is typically below one tenth of the switching frequency.

- Choose the compensation capacitor (C3) to achieve the desired phase margin. For typical applications, setting the compensation zero below one-fourth of the crossover frequency will provide sufficient phase margin.

$$C_3 > \frac{4}{2\pi * R_3 * f_C}, \text{ where } R_3 \text{ is the}$$

compensation resistor.

- If the ESR zero of the output capacitor is located at less than half of the switching frequency, or the following relationship is valid:

$$\frac{1}{2\pi * C_2 * R_{ESR}} < \frac{f_{SW}}{2}. \text{ If this is the case, then}$$

add the second compensation capacitor (C6) to set

the pole at the location of the ESR zero:

$$C_6 = \frac{C_2 * R_{ESR}}{R_3}.$$

Optional Schottky Diode Selection

During the transition between high-side switch and low-side switch, the body diode of the low-side power MOSFET conducts the inductor current. The forward voltage of the body diode is high. An optional Schottky diode may be paralleled between the SW pin and GND pin to improve overall efficiency.

TYPICAL PERFORMANCE CHARACTERISTICS

VIN=12V, Vo=3.3V, L=10uH, C1=10uF, C2=22uF, TA=+25°C, unless otherwise noted.

Efficiency vs Load Current

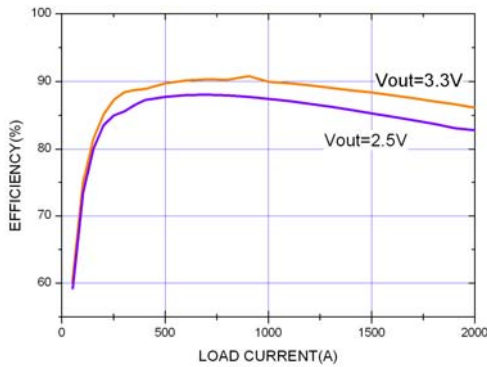

OSC Frequency vs Temperature

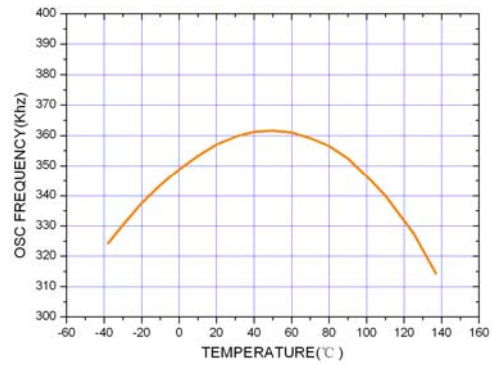

Output Voltage vs Temperature

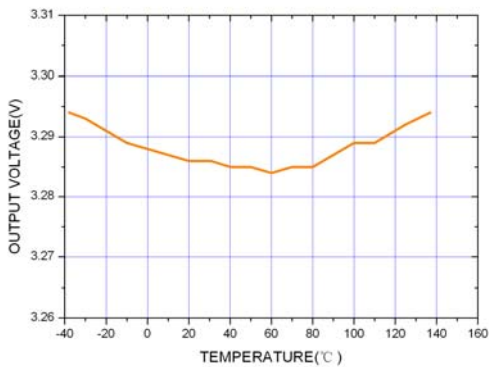

Line Regulation

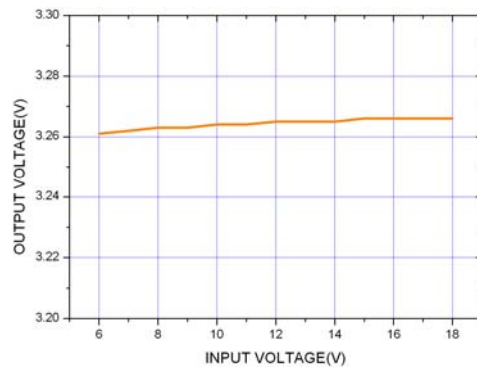

Load Regulation

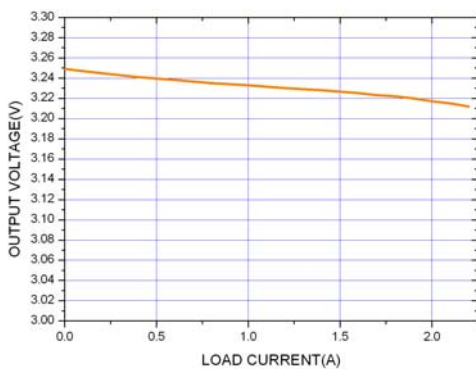

Startup through Enable

VIN=12V, VOUT=3.3V, IOU=2A (Resistance Load)

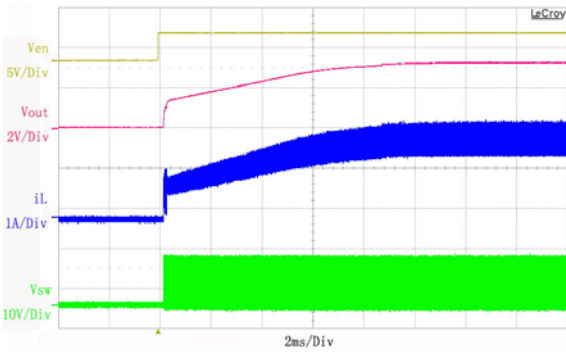

Shutdown through Enable

VIN=12V, VOUT=3.3V, IOU=2A (Resistance Load)

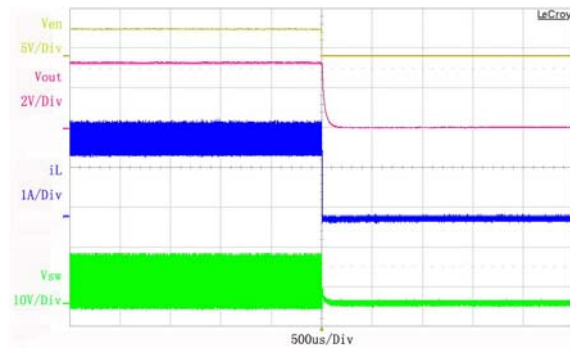

Light Load Operation

VIN=12V, VOUT=3.3V, IOU=0A, IIN=8mA

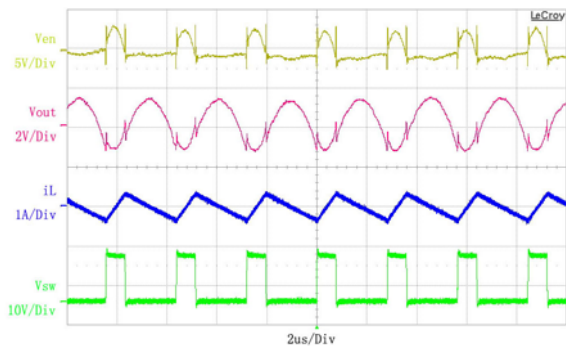

Medium Load Operation

VIN=12V, VOUT=3.3V, IOU=1A

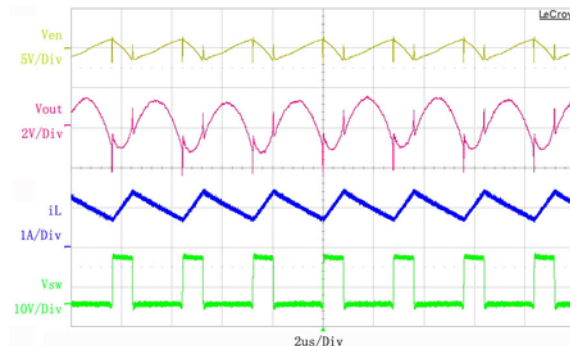

Heavy Load Operation

VIN=12V, VOUT=3.3V, IOU=2A

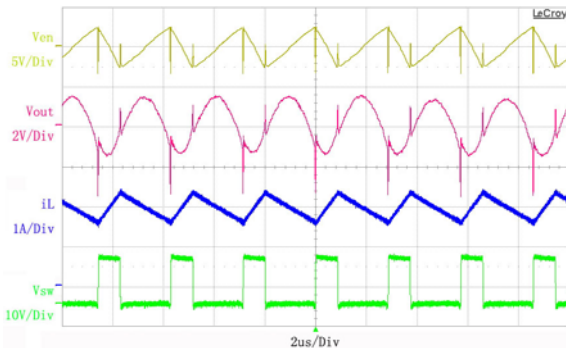

Load Transient

VIN=12V, VOUT=3.3V, IOU=0A to 1A

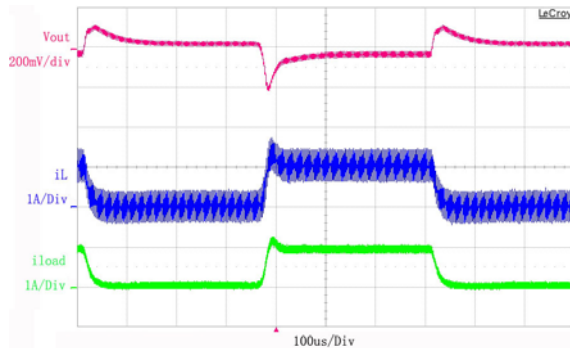

Short Circuit Protection

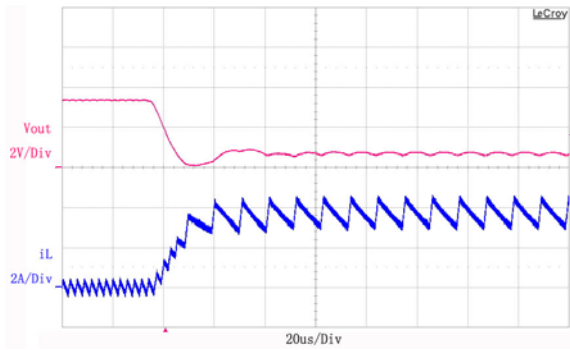

Short Circuit Recovery

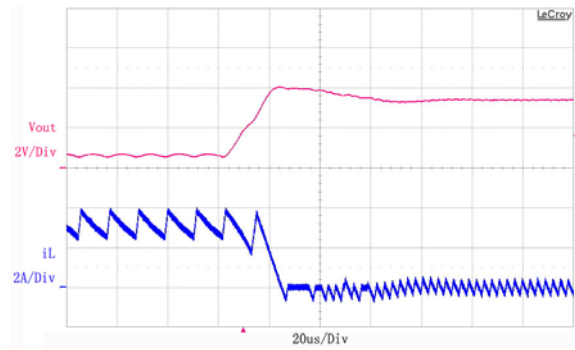

PACKAGE INFORMATION

SOP8

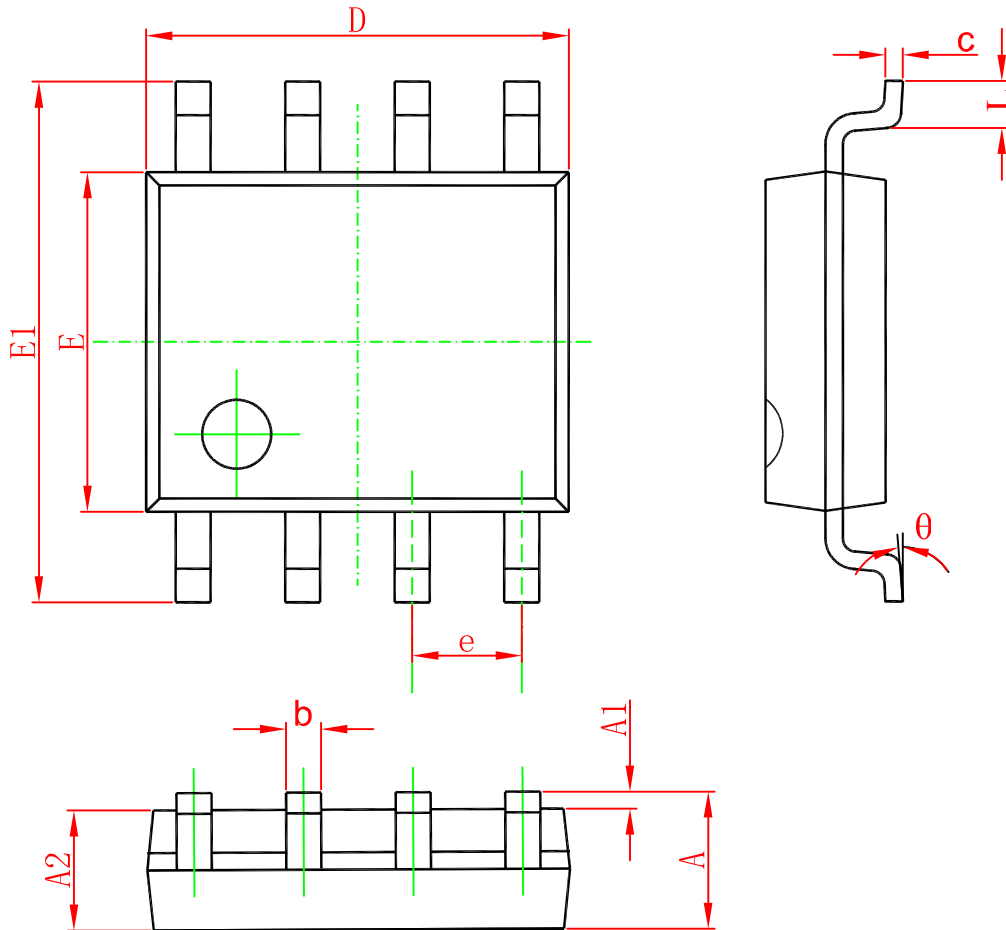

SYMBOL	DIMENSIONS IN MILLIMETERS		DIMENSIONS IN INCH	
	MIN	MAX	MIN	MAX
A	1.350	1.750	0.053	0.069
A1	0.100	0.250	0.004	0.010
A2	1.350	1.550	0.053	0.061
b	0.330	0.510	0.013	0.020
c	0.170	0.250	0.006	0.010
D	4.700	5.100	0.185	0.200
E	3.800	4.000	0.150	0.157
E1	5.800	6.200	0.228	0.244
e	1.270(BSC)		0.050(BSC)	
L	0.400	1.270	0.016	0.050
θ	0°	8°	0°	8°

ESOP8

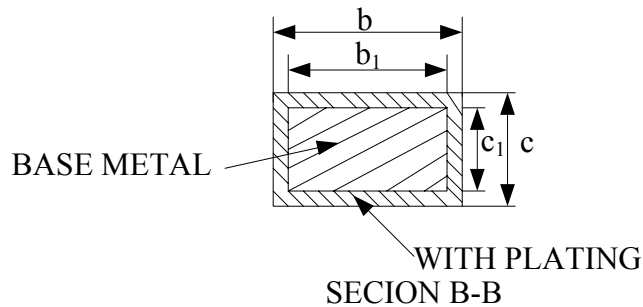
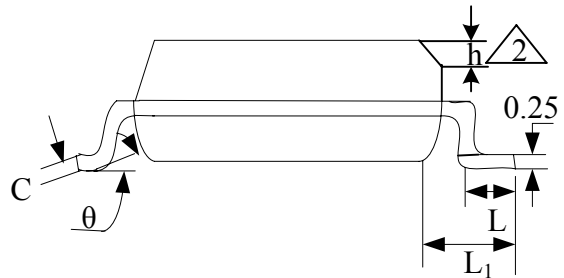
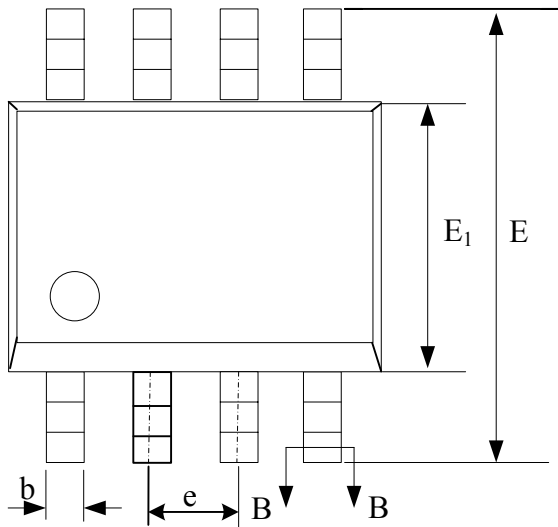
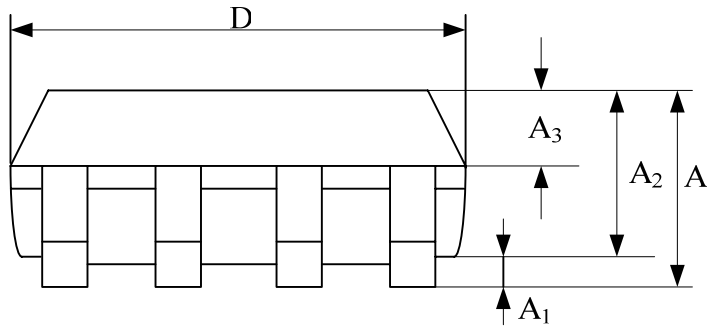
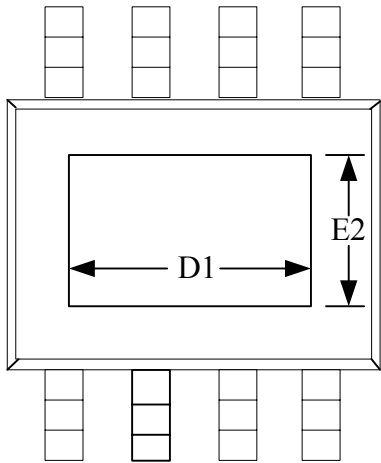

SYMBOL	MILLIMETERS		
	MIN	NOM	MAX
A	—	—	1.75
A1	0.05	—	0.15
A2	1.30	1.40	1.50
A3	0.60	0.65	0.70
b	0.39	—	0.48
b1	0.38	0.41	0.43
c	0.21	—	0.26
c1	0.19	0.20	0.21
D	4.70	4.90	5.10
E	5.80	6.00	6.20
E1	3.70	3.90	4.10
e	1.27(BSC)		
h	0.25	—	0.50
L	0.50	—	0.80
L1	1.05(BSC)		
θ	0°	—	8°
D1	2.13REF		2.90REF
E2	2.13REF		2.00REF