

**DUAL OP AMP AND VOLTAGE REFERENCE****AP4310****General Description**

The AP4310 is a monolithic IC specifically designed to regulate the output current and voltage levels of switching battery chargers and power supplies.

The device contains two Op Amps and a 2.5V precision shunt voltage reference. Op Amp 1 is designed for voltage control with its non-inverting input internally connects to the output of the shunt regulator. Op Amp 2 is for current control with both inputs uncommitted. The IC offers the power converter designer a control solution that features increased precision with a corresponding reduction in system complexity and cost.

The AP4310 is available in standard packages of DIP-8 and SOIC-8.

**Features****Op Amp**

- Input Offset Voltage: 0.5mV
- Supply Current: 75 $\mu$ A per Op Amp at 5.0V Supply Voltage
- Unity Gain Bandwidth: 1MHz
- Output Voltage Swing: 0 to ( $V_{CC} - 1.5$ ) V
- Power Supply Range: 3 to 36V

**Voltage Reference**

- Fixed Output Voltage Reference: 2.5V
- Voltage Tolerance:  $\pm 0.4\%$ ,  $\pm 1\%$
- Sink Current Capability: 0.05 to 80mA
- Typical Output Impedance: 0.2 $\Omega$

**Applications**

- Battery Charger
- Switching Power Supply

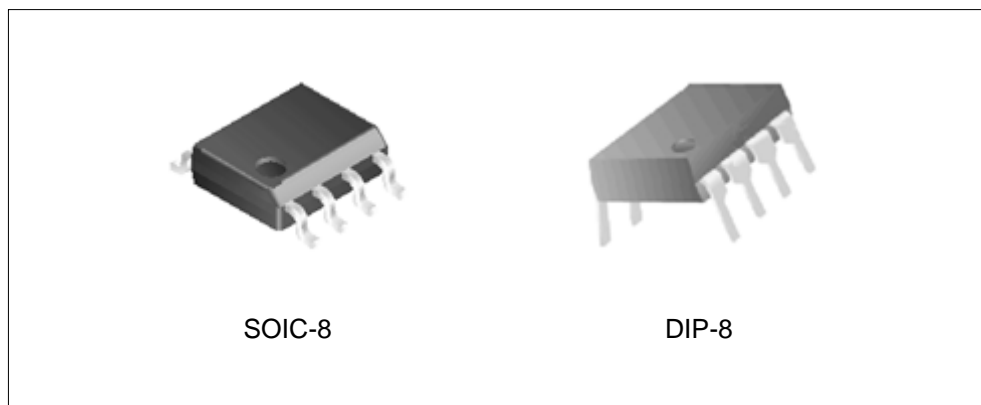

Figure 1. Package Types of AP4310



**DUAL OP AMP AND VOLTAGE REFERENCE**

**AP4310**

**Pin Configuration**

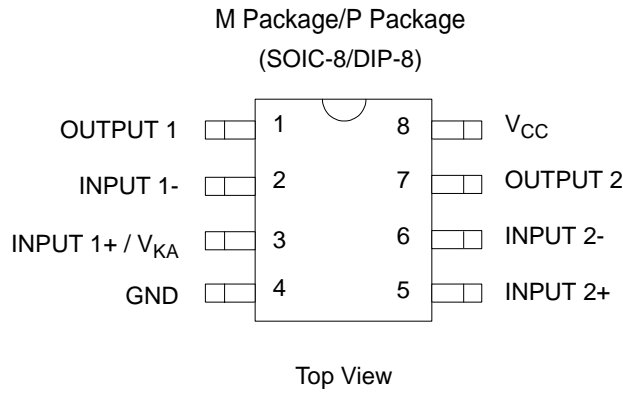

Figure 2. Pin Configuration of AP4310

**Functional Block Diagram**

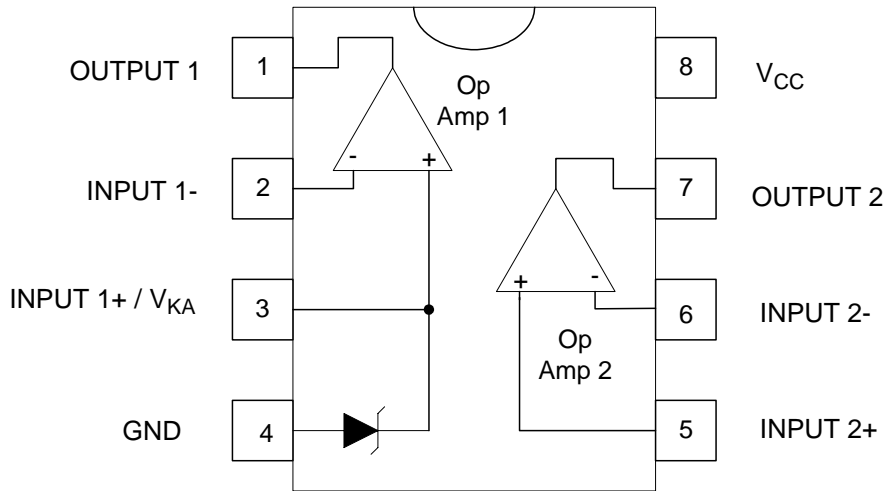

Figure 3. Functional Block Diagram of AP4310



**DUAL OP AMP AND VOLTAGE REFERENCE**

**AP4310**

**Ordering Information**

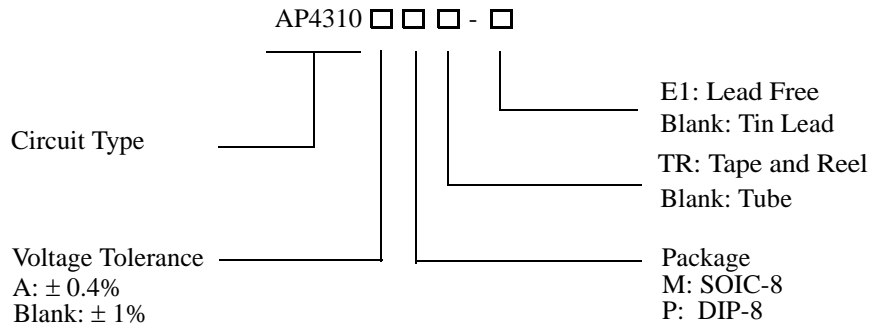

Package	Reference Voltage	Voltage Tolerance	Temperature Range	Part Number		Marking ID		Packing Type
				Tin Lead	Lead Free	Tin Lead	Lead Free	
DIP-8	2.5V	± 0.4%	-40 to 105°C	AP4310AP	AP4310AP-E1	AP4310AP	AP4310AP-E1	Tube
		± 1%		AP4310P	AP4310P-E1	AP4310P	AP4310P-E1	
SOIC-8	2.5V	± 0.4%	-40 to 105°C	AP4310AM	AP4310AM-E1	4310AM	AP4310AM-E1	Tube
				AP4310AMTR	AP4310AMTR-E1	4310AM	AP4310AM-E1	Tape & Reel
		± 1%	-40 to 105°C	AP4310M	AP4310M-E1	4310M	AP4310M-E1	Tube
				AP4310MTR	AP4310MTR-E1	4310M	AP4310M-E1	Tape & Reel

BCD Semiconductor's Pb-free products, as designated with "E1" suffix in the part number, are RoHS compliant.

**DUAL OP AMP AND VOLTAGE REFERENCE****AP4310****Absolute Maximum Ratings (Note 1)**

Parameter	Symbol	Value		Unit
Power Supply Voltage ( $V_{CC}$ to GND)	$V_{CC}$	40		V
Op Amp 1 and 2 Input Voltage Range (Pins 2, 5, 6)	$V_{IN}$	- 0.3 to $V_{CC} + 0.3$		V
Op Amp 2 Input Differential Voltage (Pins 5, 6)	$V_{ID}$	40		V
Voltage Reference Cathode Current (Pin 3)	$I_K$	100		mA
Power Dissipation	$P_D$	DIP-8	800	mW
		SOIC-8	500	
Storage Temperature Range	$T_{STG}$	-65 to 150		°C
ESD Protection Voltage (Human Body Model)		$\geq 2000$		V

Note 1: Stresses greater than those listed under "Absolute Maximum Ratings " may cause permanent damage to the device. These are stress ratings only, and functional operation of the device at these or any other conditions beyond those indicated under "Recommended Operating Conditions" is not implied. Exposure to "Absolute Maximum Ratings " for extended periods may affect device reliability.

**Recommended Operating Conditions**

Parameter	Min	Max	Unit
Supply Voltage	3	36	V
Ambient Temperature	-40	105	°C



**DUAL OP AMP AND VOLTAGE REFERENCE**

**AP4310**

**Electrical Characteristics**

Operating Conditions:  $V_{CC} = +5V$ ,  $T_A = 25^\circ C$  unless otherwise specified.

Parameter	Conditions		Min	Typ	Max	Unit	
Total Supply Current, excluding Current in Voltage Reference	$V_{CC} = 5V$ , no load, $-40^\circ C \leq T_A \leq 105^\circ C$			0.15	0.25	mA	
	$V_{CC} = 30V$ , no load, $-40^\circ C \leq T_A \leq 105^\circ C$			0.20	0.30		
<b>Voltage Reference Section</b>							
Reference Voltage	AP4310A	$I_K = 10mA$	$T_A = 25^\circ C$	2.49	2.50	2.51	V
			$-40^\circ C \leq T_A \leq 105^\circ C$	2.48	2.50	2.52	
	AP4310	$I_K = 10mA$	$T_A = 25^\circ C$	2.475	2.50	2.525	V
			$-40^\circ C \leq T_A \leq 105^\circ C$	2.45	2.50	2.55	
Reference Voltage Deviation Over Full Temperature Range	$I_K = 10mA$ , $T_A = -40$ to $105^\circ C$			5	24	mV	
Minimum Cathode Current for Regulation				0.01	0.05	mA	
Dynamic Impedance	$I_K = 1.0$ to $80mA$ , $f < 1kHz$			0.2	0.5	$\Omega$	
<b>Op Amp 1 Section</b> ( $V_{CC} = 5V$ , $V_O = 1.4V$ , $T_A = 25^\circ C$ , unless otherwise noted)							
Input Offset Voltage	$T_A = 25^\circ C$			0.5	3	mV	
	$T_A = -40$ to $105^\circ C$				5		
Input Offset Voltage Temperature Drift	$T_A = -40$ to $105^\circ C$				7	$\mu V/^\circ C$	
Input Bias Current (Inverting Input Only)	$T_A = 25^\circ C$			20	150	nA	
Large Signal Voltage Gain	$V_{CC} = 15V$ , $R_L = 2K\Omega$ , $V_O = 1.4$ to $11.4V$		85	100		dB	
Power Supply Rejection Ratio	$V_{CC} = 5$ to $30V$		70	90		dB	
Output Current	Source	$V_{CC} = 15V$ , $V_{ID} = 1V$ , $V_O = 2V$	20	40		mA	
	Sink	$V_{CC} = 15V$ , $V_{ID} = -1V$ , $V_O = 2V$	7	20		mA	
Output Voltage Swing (High)	$V_{CC} = 30V$ , $R_L = 10K\Omega$ , $V_{ID} = 1V$		27	28		V	
Output Voltage Swing (Low)	$V_{CC} = 30V$ , $R_L = 10K\Omega$ , $V_{ID} = -1V$			17	100	mV	
Slew Rate	$V_{CC} = 18V$ , $R_L = 2k\Omega$ , $A_V = 1$ , $V_{IN} = 0.5$ to $2V$ , $C_L = 100pF$		0.2	0.5		$V/\mu s$	
Unity Gain Bandwidth	$V_{CC} = 30V$ , $R_L = 2k\Omega$ , $C_L = 100pF$		0.7	1.0		MHz	



**DUAL OP AMP AND VOLTAGE REFERENCE**

**AP4310**

**Electrical Characteristics (Continued)**

Operating Conditions:  $V_{CC} = +5V$ ,  $T_A = 25^\circ C$  unless otherwise specified.

Parameter	Conditions	Min	Typ	Max	Unit
<b>Op Amp 2 Section</b> ( $V_{CC} = 5V$ , $V_O = 1.4V$ , $T_A = 25^\circ C$ , unless otherwise noted)					
Input Offset Voltage	$T_A = 25^\circ C$		0.5	3	mV
	$T_A = -40$ to $105^\circ C$			5	
Input Offset Voltage Temperature Drift	$T_A = -40$ to $105^\circ C$			7	$\mu V/^\circ C$
Input Offset Current	$T_A = 25^\circ C$		2	30	nA
Input Bias Current	$T_A = 25^\circ C$		20	150	nA
Input Voltage Range	$V_{CC} = 0$ to $36V$	0		$V_{CC} - 1.5$	V
Common Mode Rejection Ratio	$T_A = 25^\circ C$ , $V_{CM} = 0$ to $3.5V$	70	85		dB
Large Signal Voltage Gain	$V_{CC} = 15V$ , $R_L = 2k\Omega$ , $V_O = 1.4$ to $11.4V$	85	100		dB
Power Supply Rejection Ratio	$V_{CC} = 5$ to $30V$	70	90		dB
Output Current	Source	$V_{CC} = 15V$ , $V_{ID} = 1V$ , $V_O = 2V$	20	40	mA
	Sink	$V_{CC} = 15V$ , $V_{ID} = -1V$ , $V_O = 2V$	7	20	
Output Voltage Swing (High)	$V_{CC} = 30V$ , $R_L = 10k\Omega$ , $V_{ID} = 1V$	27	28		V
Output Voltage Swing (Low)	$V_{CC} = 30V$ , $R_L = 10k\Omega$ , $V_{ID} = -1V$		17	100	mV
Slew Rate	$V_{CC} = 18V$ , $R_L = 2k\Omega$ , $A_V = 1$ , $V_{IN} = 0.5$ to $2V$ , $C_L = 100pF$	0.2	0.5		$V/\mu s$
Unity Gain Bandwidth	$V_{CC} = 30V$ , $R_L = 2k\Omega$ , $C_L = 100pF$	0.7	1.0		MHz



**DUAL OP AMP AND VOLTAGE REFERENCE**

**AP4310**

**Typical Performance Characteristics**

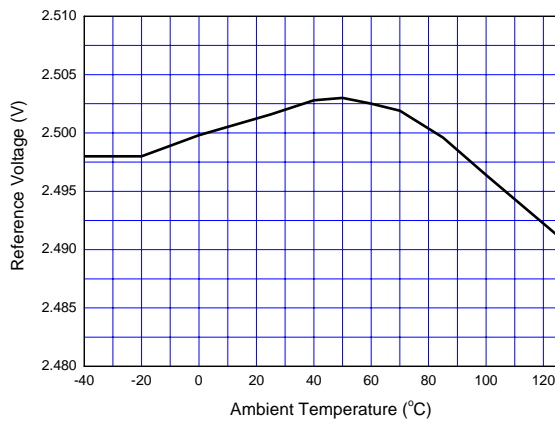

Figure 4. Reference Voltage vs. Ambient Temperature

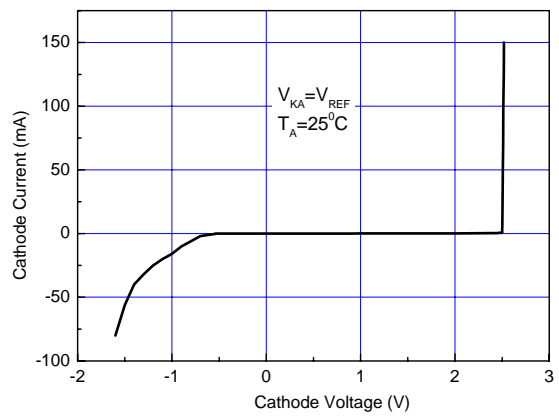

Figure 5. Cathode Current vs. Cathode Voltage

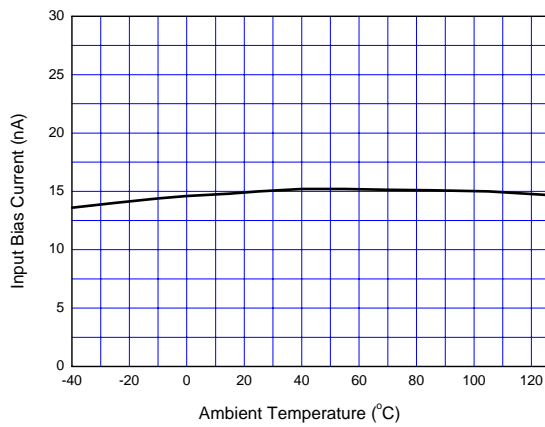

Figure 6. Input Bias Current vs. Ambient Temperature

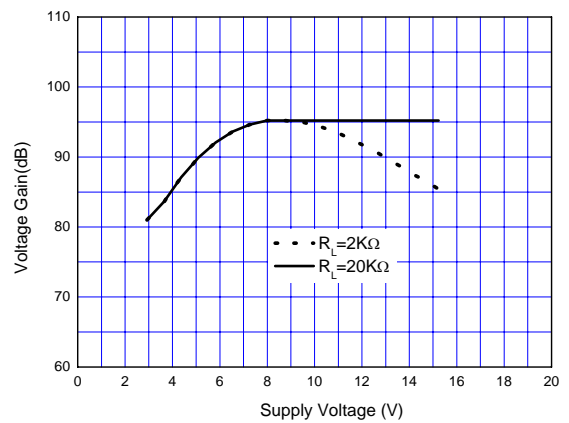

Figure 7. Op Amp Voltage Gain



**DUAL OP AMP AND VOLTAGE REFERENCE**

**AP4310**

**Typical Application**

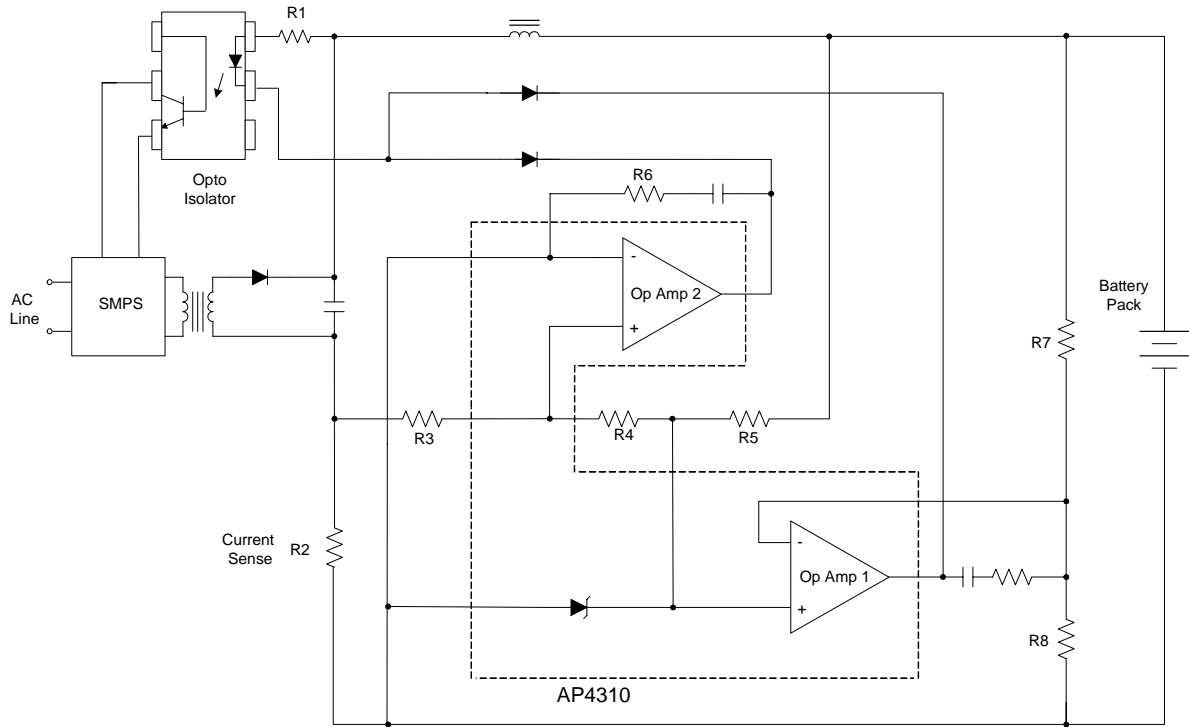

Figure 8. Application of AP4310 in a Constant Current and Constant Voltage Charger





**DUAL OP AMP AND VOLTAGE REFERENCE**

**AP4310**

**Mechanical Dimensions:**

**DIP-8**

**Unit: mm(inch)**

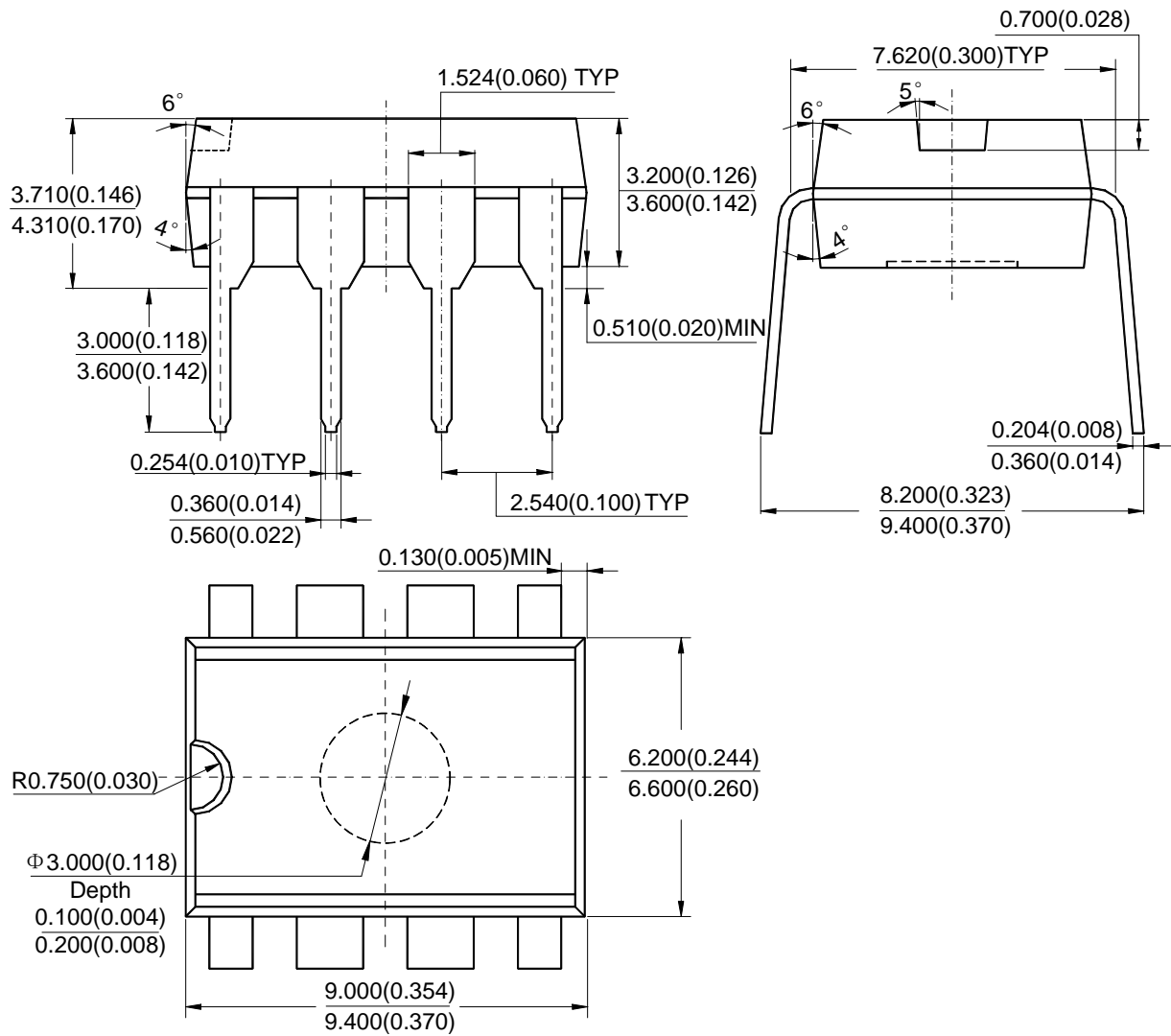





BCD Semiconductor Manufacturing Limited

<http://www.bcdsemi.com>

---

**BCD Semiconductor Corporation**

3170 De La Cruz Blvd, Suite # 105 Santa Clara, CA 95054-2411, U.S.A

Tel: +1-408-988 6388, Fax: +1-408-988 6386

**Shanghai SIM-BCD Semiconductor Manufacturing Co., Ltd.**

800 Yi Shan Road, Shanghai 200233, PRC

Tel: +86-21-6485-1491, Fax: +86-21-5450-0008

**Advanced Analog Circuits (Shanghai) Corporation**

8F, B Zone, 900 Yi Shan Road, Shanghai 200233, PRC

Tel: +86-21-6495 9539, Fax: +86-21-6485 9673

**BCD Semiconductor (Taiwan) Company Limited**

Room 2210, 22nd Fl, 333, Keelung Road, Sec. 1, TaiPei (110), Taiwan

Tel: +886-2-2758 6828, Fax: +886-2-2758 6892

**IMPORTANT NOTICE**

BCD Semiconductor Manufacturing Limited reserves the right to make changes without further notice to any products or specifications herein. BCD Semiconductor Manufacturing Limited does not assume any responsibility for use of any its products for any particular purpose, nor does BCD Semiconductor Manufacturing Limited assume any liability arising out of the application or use of any its products or circuits. BCD Semiconductor Manufacturing Limited does not convey any license under its patent rights or other rights nor the rights of others.