

IS31BL3508A 1.0MHZ BOOST CONVERTER WITH 38V INTERNAL MOSFET SWITCH

DESCRIPTION

IS31BL3508A is a 2.7V~5.5V (input voltage) backlight LED boost converter with an integrated MOSFET switch. It is designed for driving a string of LEDs or other devices in a constant current mode. The device regulates the LED load current using an external, low value sensing resistor. The device adjusts the PWM duty cycle of the switch to maintain the voltage at the FB pin at a value of 0.3V. The IS31BL3508A operates at a constant switching frequency of 1.0MHz to utilize small component sizes. It features an over voltage shutdown pin which prevents the output voltage from exceeding 38V (typ.) for open circuit condition.

FEATURES

- Supply voltage: 2.7V~5.5V
- Built-in soft start
- Drive series strings of 10 LEDs
- PWM or DC voltage dimming
- Frequency of PWM is 500Hz ~ 500kHz
- 1.0MHz high speed switching frequency
- 300mV feedback voltage
- Integrated high power MOSFET
- Over voltage protection
- -40°C ~ +85°C working temperature range
- TSOT-23-6 and SOT-23-6 package

QUICK START

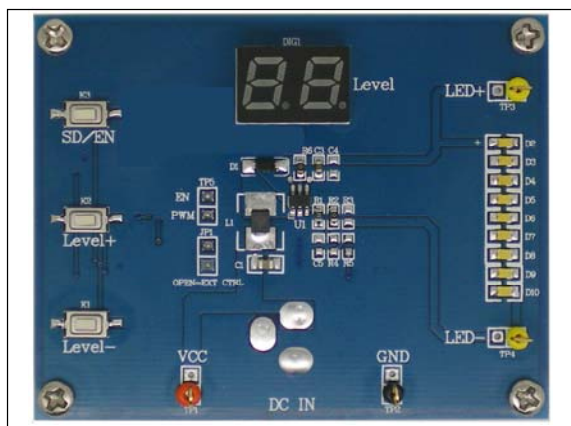

Figure 1: Photo of IS31BL3508A Evaluation Board

RECOMMENDED EQUIPMENT

- 5.0V, 2A power supply

ABSOLUTE MAXIMUM RATINGS

- ≤ 5.5V power supply

Caution: Do not exceed the conditions listed above, otherwise the board will be damaged.

PROCEDURE

The IS31BL3508A evaluation board is fully assembled and tested. Follow the steps listed below to verify board operation.

Caution: Do not turn on the power supply until all connections are completed.

- 1) Connect the Power Supply ground terminal to the PCB GND input pin and the positive terminal to the PCB VCC input pin. Or connect a wall-mount DC power out plug (center power) to the PCB connector (CON1 / DC IN).
- 2) Turn on the power supply and pay attention to the supply current. If the current exceeds 2A, please check for circuit fault.

EVALUATION BOARD OPERATION

The WLED light intensity is adjusted by the onboard MCU (LPC936) which generates a PWM signal to the IS31BL3508A EN pin 4. There are 32 intensity levels with the lowest set as the power on default. Pressing the Level+ key will increase the intensity level while pressing the Level- key will decrease the level. The 7-segment LED (DIG1) will show the corresponding light intensity level. The SD/EN key is used to toggle between shutdown and enable modes. The LED+ and LED- are test points to monitor the output voltage.

LED CURRENT SETTING

When the IS31BL3508A is used for driving LEDs, the LED current flows through the external feedback resistor R1 and R2 to regulate the LED current. The internal feedback regulation point is 0.3V.

The maximum LED current may be calculated by the following Equation:

$$I_{MAX} = V_{FB} / R_{SET} \quad \text{and} \quad R_{SET} = R_1 / R_2, \quad (R_2=1\Omega \text{ if zero ohm resistor used}).$$
 For accurate LED current, resistors should be 1% or better tolerance.

IS31BL3508A 1.0MHZ BOOST CONVERTER WITH 38V INTERNAL MOSFET SWITCH

SOFTWARE SUPPORT

JP1 is connected by default. Open it to disable the onboard MCU which will place the IS31BL3508A EN pin in High impedance. An external driving signal can then be connected to TP5 connector to control the

IS31BL3508A LED driver. Please refer to the SW program for LPC936 code example.

Please refer to the datasheet to get more information about IS31BL3508A.

ORDERING INFORMATION

Part No.	Temperature Range	Package
IS31BL3508A-STLS2-EB	-40°C ~ +85°C (Industrial)	SOT23-6, Lead-free

Table1: Ordering Information

For pricing, delivery, and ordering information, please contacts ISSI's analog marketing team at analog@issi.com or (408) 969-6600.

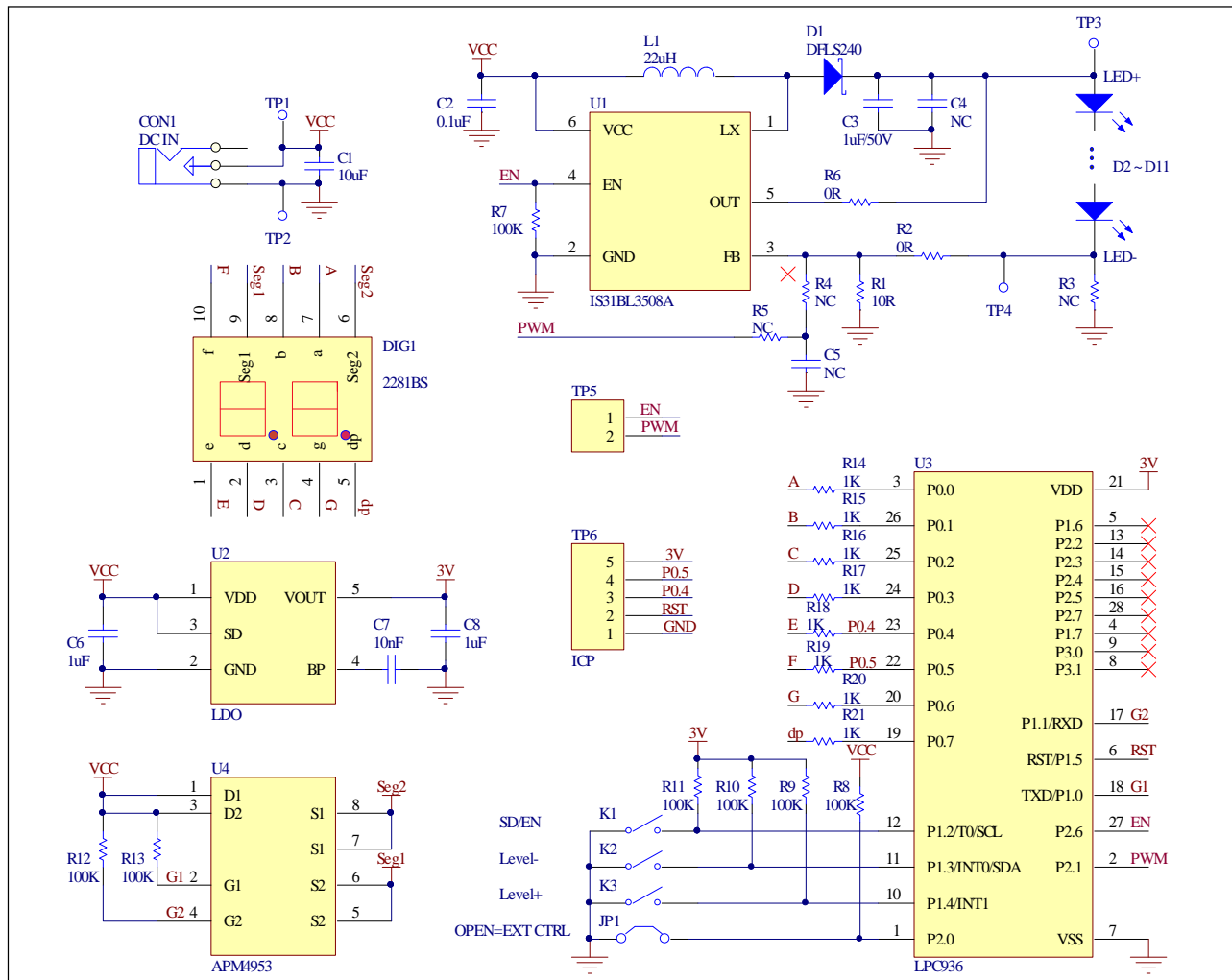

Figure 2: IS31BL3508A Application Schematic

**IS31BL3508A 1.0MHZ BOOST CONVERTER
WITH 38V INTERNAL MOSFET SWITCH**



BILL OF MATERIALS

Name	Symbol	Description	Qty	Supplier	Part No.
LED Driver	U1	LED boost converter driver	1	ISSI	IS31BL3508A
LDO	U2	Low-dropout regulator	1	PAM	PAM3101
MCU	U3	Microcontroller	1	NXP	LPC936
PMOS	U4	Dual PMOS	1	ANPEC	APM4953
Display	DIG1	Dual digit display common anode	1	ZSO	2281BS
Diode	D1	Schottky Diode, SMD	1		DFLS240
Diode	D2~D11	Diode, LED White, SMD	10	Everlight	EHP-C04/UT01-P01/TR
Inductor	L1	IND,22 μ H \pm 20%,SMD	1	murata	
Resistor	R1	RES,10R,1/16W, \pm 5%,SMD	1		
Resistors	R2,R6	RES,0R,1/16W, \pm 5%,SMD	2		
	R3,R4,R5,C4,C5	Not connect	5		
Resistors	R7~R13	RES,100k,1/16W, \pm 5%,SMD	7		
Resistors	R14~R21	RES,1k,1/16W, \pm 5%,SMD	8		
Capacitor	C1	CAP,10 μ F,16V, \pm 20%,SMD	1		
Capacitors	C2	CAP, 0.1 μ F,16V, \pm 20%,SMD	1		
Capacitors	C3,C6,C8	CAP,1 μ F,50V, \pm 20%,SMD	3		
Capacitor	C7	CAP,10nF,16V, \pm 20%,SMD	1		
Buttons	K1~K3	Buttons SMD	3		

Bill of materials, refer to Figure 2 above.

**IS31BL3508A 1.0MHZ BOOST CONVERTER
WITH 38V INTERNAL MOSFET SWITCH**

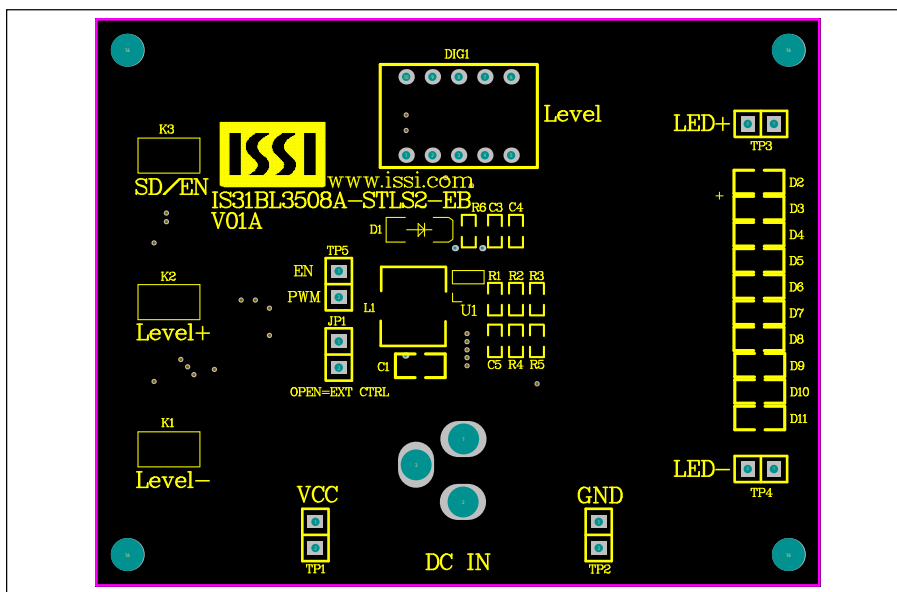

Figure 3: Board Component Placement Guide - Top Layer

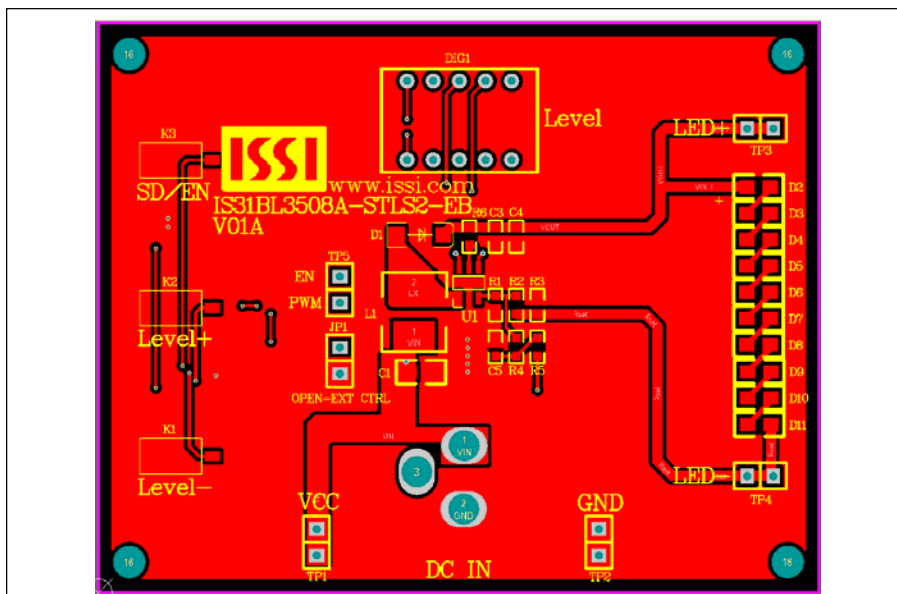

Figure 4: Board PCB Layout- Top Layer

IS31BL3508A 1.0MHZ BOOST CONVERTER WITH 38V INTERNAL MOSFET SWITCH

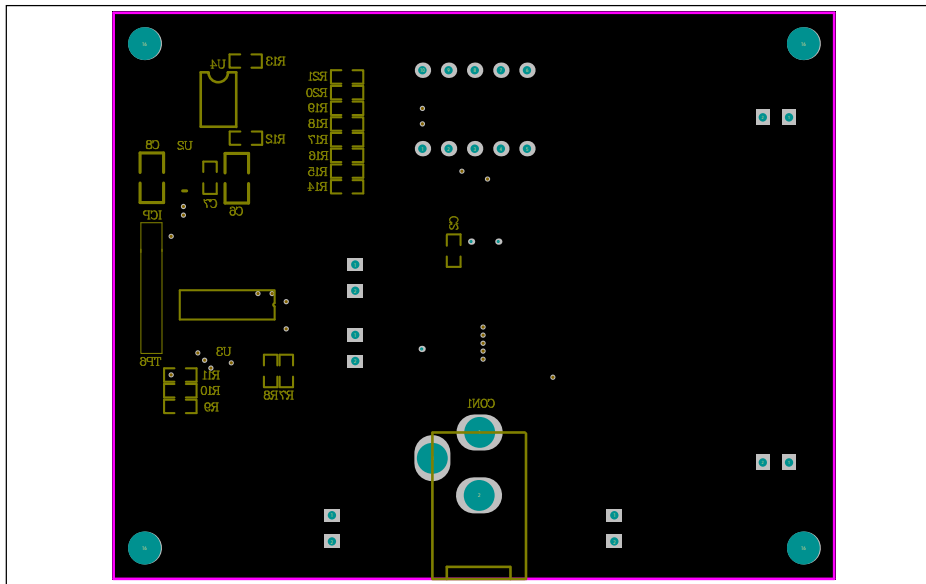

Figure 5: Board Component Placement Guide -Bottom Layer

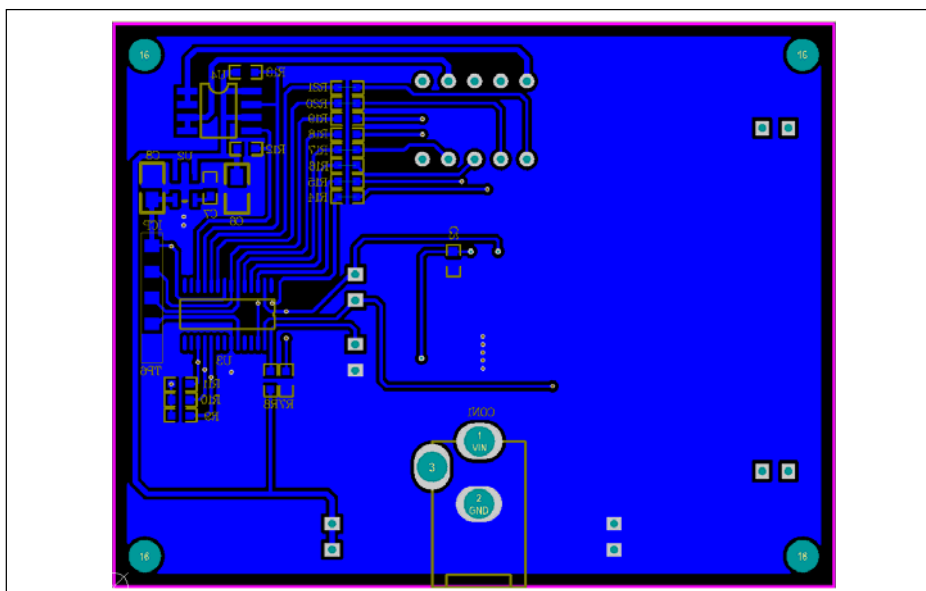

Figure 6: Board PCB Layout -Bottom Layer

Copyright © 2013 Integrated Silicon Solution, Inc. All rights reserved. ISSI reserves the right to make changes to this specification and its products at any time without notice. ISSI assumes no liability arising out of the application or use of any information, products or services described herein. Customers are advised to obtain the latest version of this device specification before relying on any published information and before placing orders for products.

Integrated Silicon Solution, Inc. does not recommend the use of any of its products in life support applications where the failure or malfunction of the product can reasonably be expected to cause failure of the life support system or to significantly affect its safety or effectiveness. Products are not authorized for use in such applications unless Integrated Silicon Solution, Inc. receives written assurance to its satisfaction, that:

- a.) the risk of injury or damage has been minimized;
- b.) the user assume all such risks; and
- c.) potential liability of Integrated Silicon Solution, Inc is adequately protected under the circumstances