

1A Linear Li-Ion Battery Charger in SOP8/MSOP8



General Description

The FP8102 is a standalone linear Li-ion battery charger with exposed pad SOP8/MSOP8 package. With few external components, FP8102 is well suited for a wide range of portable applications. Charging current can be programmed by an external resistor. In standby mode, supply current will be reduced to around 55uA. Other features include UVLO, automatic recharge, charge status indicators and thermal regulation.

Features

- Standalone Linear Charger for Single Cell Li-ion Batteries
- No External MOSFET, Sense Resistor, or Blocking Diode Required
- Up to 1A Programmable Charge Current
- Preset Charge Voltage with $\pm 1\%$ Accuracy
- Automatic Recharge
- 2.9V Trickle Charge Voltage
- C/10 Charge Termination
- 55uA Standby Supply Current
- Charge Status Indicators for No Battery and Charge Failure Display
- Soft-Start to Limit Inrush Current
- Thermal Protection

Applications

- Portable Information Appliances
- Charging Docks & Cradles
- Cellular Phones & PDAs
- Handheld Computers

Typical Application Circuit

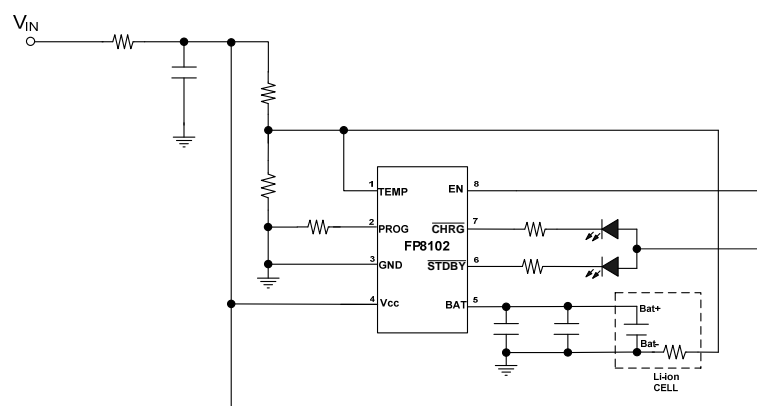

This datasheet contains new product information. Feeling Technology reserves the rights to modify the product specification without notice. No liability is assumed as a result of the use of this product. No rights under any patent accompany the sales of the product.

Function Block Diagram

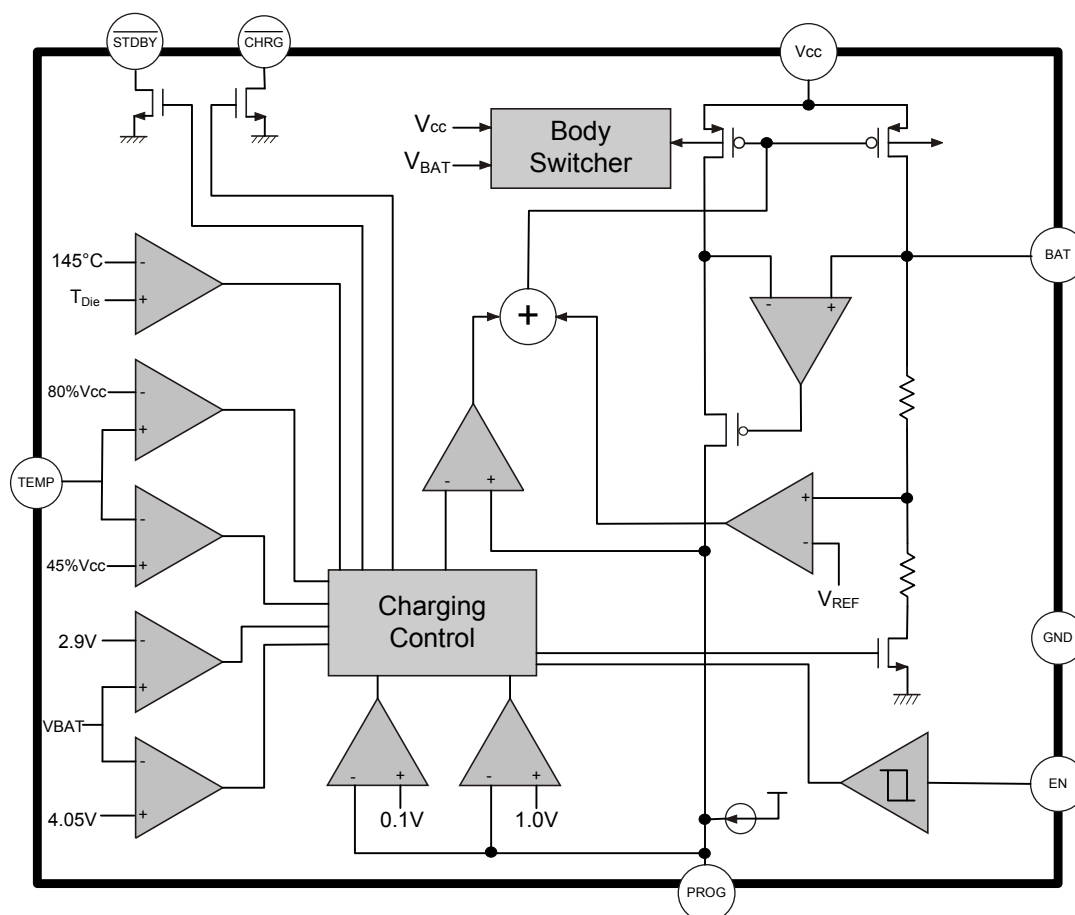

Charge Status Indicators

Charge Status	CHRG (Red)	STDBY (Green)
In Charging	ON	OFF
Charge Termination	OFF	ON
UVLO, OverT, UnderT, NoBat(with TEMP used)	OFF	OFF

This datasheet contains new product information. Feeling Technology reserves the rights to modify the product specification without notice. No liability is assumed as a result of the use of this product. No rights under any patent accompany the sales of the product.

State Diagram

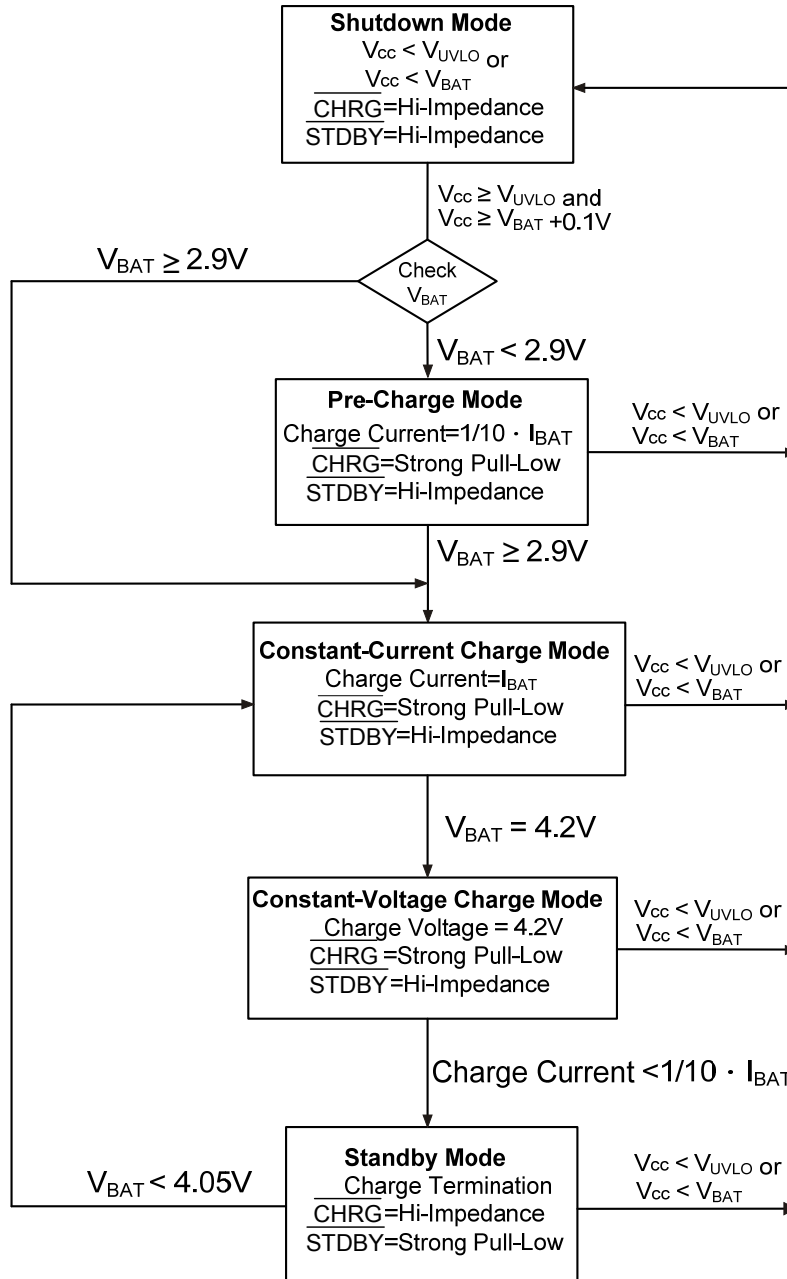

This datasheet contains new product information. Feeling Technology reserves the rights to modify the product specification without notice. No liability is assumed as a result of the use of this product. No rights under any patent accompany the sales of the product.

Pin Descriptions

SOP-8L (EP)

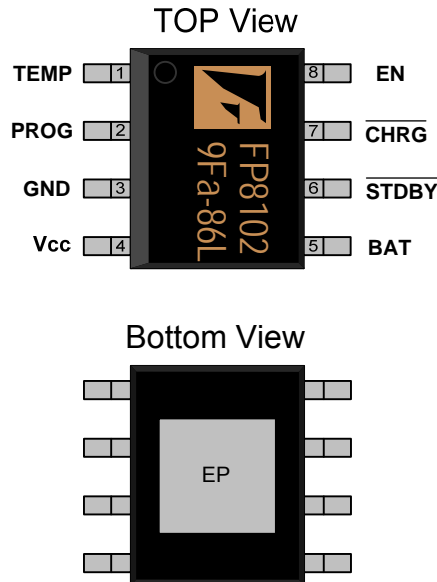

Name	No.	I / O	Description
TEMP	1	I	Battery Temperature Detector
PROG	2	I	CC Charge Current Setting & Monitor
GND	3	P	IC Ground
V _{cc}	4	P	Supply Voltage
BAT	5	P	Battery Voltage
STDBY	6	O	Charge State Indicator2
CHRG	7	O	Charge State Indicator1
EN	8	I	Enable Control

MSOP-8L (EP)

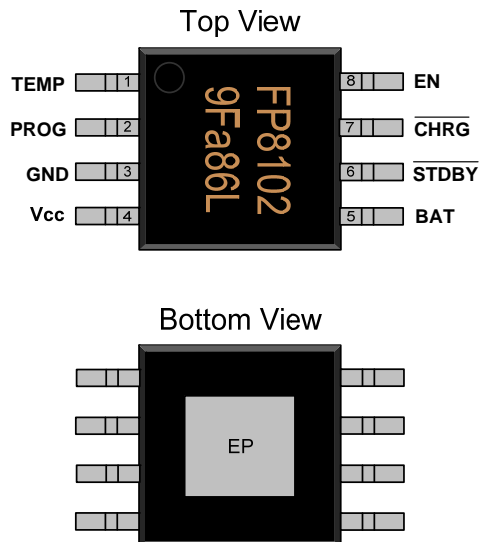

Name	No.	I / O	Description
TEMP	1	I	Battery Temperature Detector
PROG	2	I	CC Charge Current Setting & Monitor
GND	3	P	IC Ground
V _{cc}	4	P	Supply Voltage
BAT	5	P	Battery Voltage
STDBY	6	O	Charge State Indicator2
CHRG	7	O	Charge State Indicator1
EN	8	I	Enable Control

This datasheet contains new product information. Feeling Technology reserves the rights to modify the product specification without notice. No liability is assumed as a result of the use of this product. No rights under any patent accompany the sales of the product.

Marking Information

SOP-8L (EP)

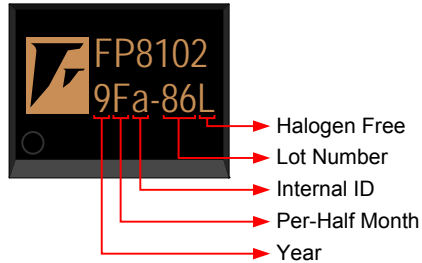

MSOP-8L (EP)

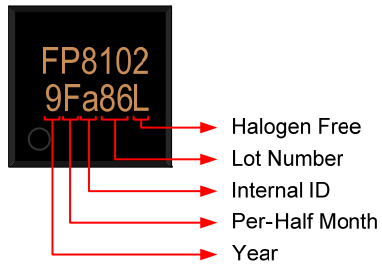

Halogen Free: Halogen free product indicator

Lot Number: Wafer lot number's last two digits

For Example: 132386TB → 86

Internal ID: Internal Identification Code

Per-Half Month: Production period indicated in half month time unit

For Example: January → A (Front Half Month), B (Last Half Month)

February → C (Front Half Month), D (Last Half Month)

Year: Production year's last digit

Ordering Information

Part Number	Operating Temperature	Package	MOQ	Description
FP8102XR-G1	-40°C ~ +85°C	SOP-8L(EP)	2500EA	Tape & Reel
FP8102gR-G1	-40°C ~ +85°C	MSOP-8L(EP)	2500EA	Tape & Reel

Absolute Maximum Ratings

Parameter	Symbol	Conditions	Min.	Typ.	Max.	Unit
Supply Voltage	V_{CC}		-0.3		6	V
All Other Pins			-0.3		6	V
BAT Pin Current	I_{BAT}				1.2	A
PROG Pin Current	I_{PROG}				1.2	mA
Junction Temperature	T_J				+150	°C
Storage Temperature	T_S		-65		+150	°C
Thermal Resistance	θ_{JA}	SOP-8L(EP)			60	°C / W
	θ_{JC}				10	°C / W
Thermal Resistance	θ_{JA}	MSOP-8L(EP)			70	°C / W
	θ_{JC}				10	°C / W
Operating Temperature			-40		+85	°C
Lead Temperature (Soldering, 10 Sec)					+260	°C

Suggested IR Re-flow Soldering Curve

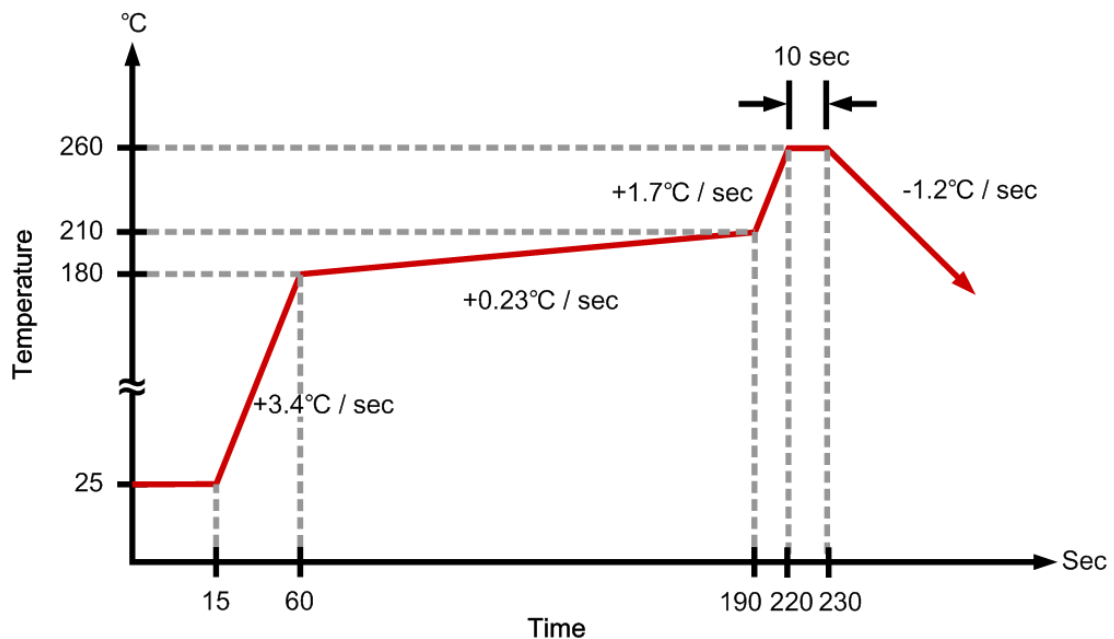

This datasheet contains new product information. Feeling Technology reserves the rights to modify the product specification without notice. No liability is assumed as a result of the use of this product. No rights under any patent accompany the sales of the product.

Recommended Operating Conditions

Parameter	Symbol	Conditions	Min.	Typ.	Max.	Unit
Supply Voltage	V_{CC}		4.25		5.5	V
Operating Temperature		Ambient Temperature	-40		85	°C

DC Electrical Characteristics ($V_{CC}=5V$, $T_A=25^\circ C$, unless otherwise noted)

Parameter	Symbol	Test Conditions	Min.	Typ.	Max.	Unit
Standby Current	I_{SB}	Charge Termination		55	100	μA
Shutdown Supply Current	I_{ST}	$V_{CC} < V_{BAT}$, $V_{CC} < V_{UVLO}$ R_{PROG} not connect		55	100	μA
CV Output (Float) Voltage	V_{FLOAT}	$0^\circ C < T_A < 85^\circ C$	4.158	4.2	4.242	V
BAT Pin Current	I_{BAT}	$R_{PROG}=2K$	540	600	660	mA
		$R_{PROG}=1.2K$	900	1000	1100	mA
		Standby-Mode, $V_{BAT}=4.2V$	0	-2.5	-6	μA
		Shutdown-Mode,		± 1	± 2	μA
		Sleep-Mode, $V_{CC}=0V$		-1	-2	μA
Trickle Charge Current	I_{TRIKL}	$V_{BAT} < V_{TRIKL}$, $R_{PROG}=2K$	30	60	85	mA
Trickle Charge Threshold Voltage	V_{TRIKL}	$R_{PROG}=2K$, V_{BAT} Rising	2.8	2.9	3.0	V
Trickle Charge Hysteresis Voltage	V_{TRKHYS}	$R_{PROG}=2K$		200		mV
V_{CC} Under Voltage Lockout Threshold	V_{UV}	V_{CC} Rising	3.5	3.7	3.9	V
V_{CC} Under Voltage Lockout Threshold Hysteresis	V_{UVHYS}			200		mV
$V_{CC}-V_{BAT}$ Lockout Threshold	V_{ASD}	V_{CC} Rising		80		mV
		V_{CC} Falling		30		mV
PMOSFET On Resistance	R_{ON}			650		m Ω
C/10 Termination Current Threshold	I_{TERM}	$R_{PROG}=2K$		60		mA
		$R_{PROG}=1.2K$		100		mA
PROG Pin Voltage	V_{PROG}	$R_{PROG}=1.2K$, Current Mode	0.9	1.0	1.1	V
CHRGB Pin Output Low Voltage	V_{CHRG}	$I_{CHRG}=5mA$		0.3	0.6	V
STDBYB Pin Output Low Voltage	V_{STDBY}	$I_{STDBY}=5mA$		0.3	0.6	V
Battery Recharge Threshold Voltage	V_{RECHRG}	$V_{FLOAT}-V_{RECHRG}$		150		mV
Temperature Limiting	T_{LIM}			145		°C
TEMP Pin High Threshold Voltage	V_{TEMP-H}			80		% V_{CC}
TEMP Pin Low Threshold Voltage	V_{TEMP-L}			45		% V_{CC}
Soft-Start Time	T_{SS}	$I_{BAT}=0$ to $I_{BAT}=1200V/R_{PROG}$		20		μs
Recharge Comparator Filter Time	T_{RECHRG}	V_{BAT} High to Low	0.8	1.8	4	mS
C/10 Termination Comparator Filter Time	T_{TERM}	I_{BAT} Falling below I_{TERM}	0.8	1.8	4	mS
PROG Pin Pull-up Current	I_{PROG}			2		μA

This datasheet contains new product information. Feeling Technology reserves the rights to modify the product specification without notice. No liability is assumed as a result of the use of this product. No rights under any patent accompany the sales of the product.

Typical Operating Characteristics

($V_{CC}=5V$, $T_A=25^\circ C$, unless otherwise noted)

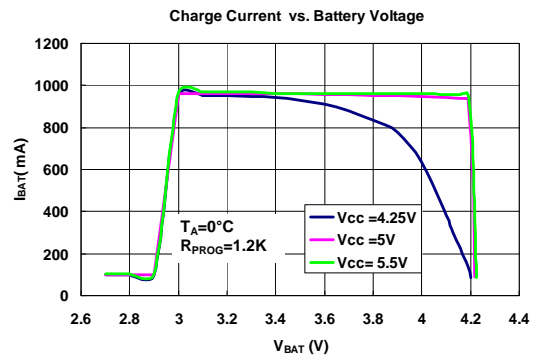
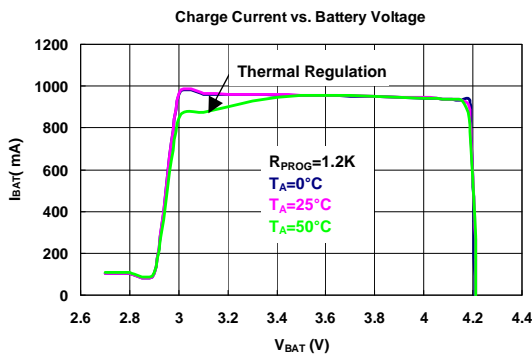
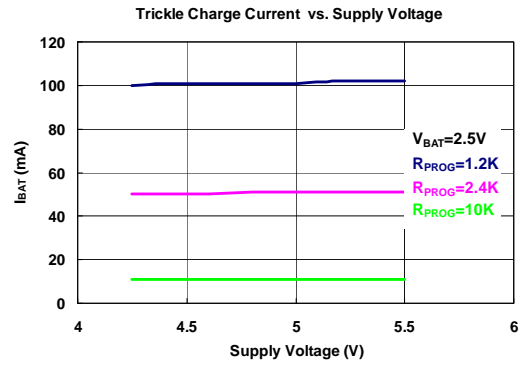
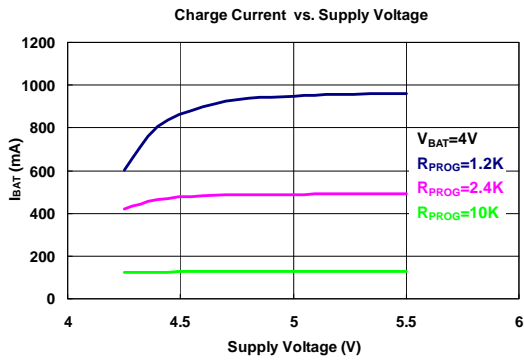
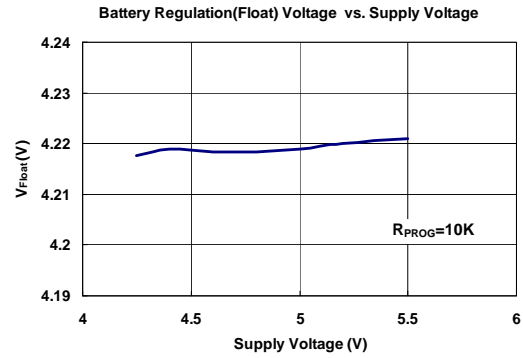
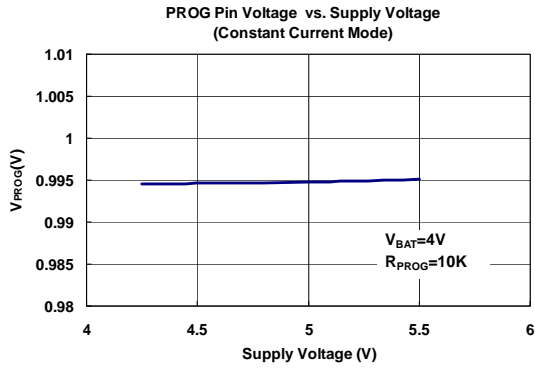

This datasheet contains new product information. Feeling Technology reserves the rights to modify the product specification without notice. No liability is assumed as a result of the use of this product. No rights under any patent accompany the sales of the product.

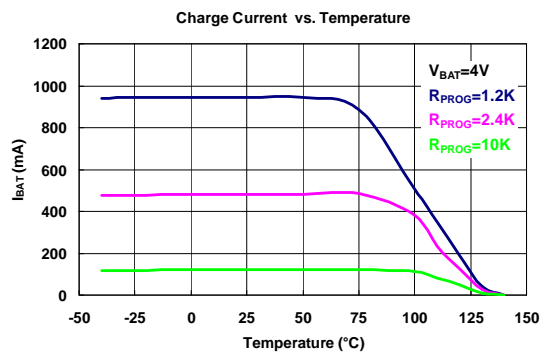
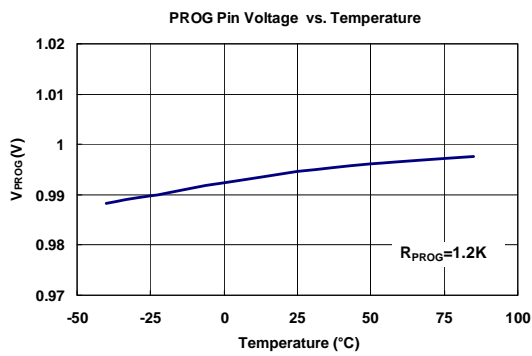
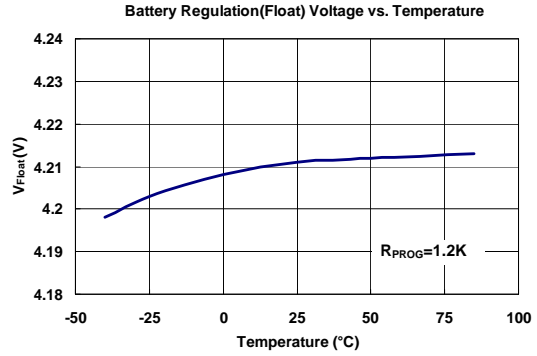
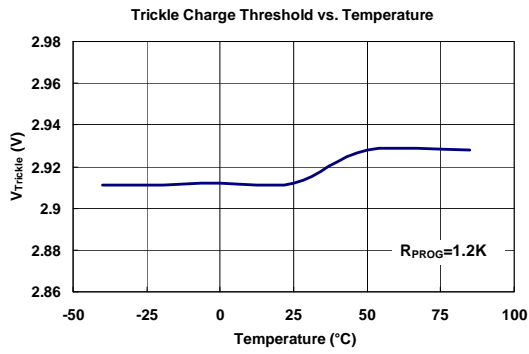
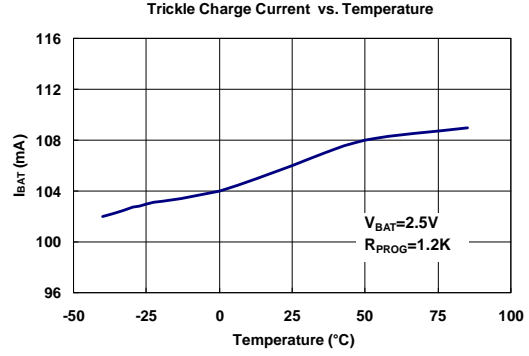
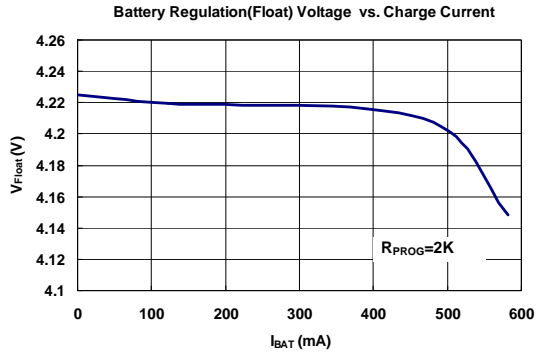

This datasheet contains new product information. Feeling Technology reserves the rights to modify the product specification without notice. No liability is assumed as a result of the use of this product. No rights under any patent accompany the sales of the product.

Function Description

Operation

The FP8102 is a linear battery charger designed primarily for charging single cell lithium-ion batteries. The charger uses a constant-current/constant-voltage charging algorithm with programmable current. Charging current can be programmed by an external single resistor. The FP8102 includes an internal P-channel power MOSFET and thermal regulation circuitry. No blocking diode or external sense resistor are required. Thus, the basic charger circuit requires only two external components. Furthermore, The FP8102 is capable of operating from a USB power source.

Normal Charge Cycle

A charge cycle begins when the voltage at the V_{cc} pin rises above the UVLO threshold. If the BAT pin voltage is smaller than 2.9V, the charger enter trickle charge mode. In this mode, the FP8102 supplies approximately 1/10 the programmed charging current to bring the battery voltage up to a safe level for full current charging. When the BAT pin voltage rises above 2.9V, the charger enters constant-current mode, where the full programmed charge current is supplied to the battery. When the BAT pin approaches the final float voltage (4.2V), the FP8102 enters the constant-voltage mode and the charge current begins to decrease. When the charge current drops to 1/10 of the programmed value, the charge cycle ends.

Programming Charge Current

The charge current is programmed by a single resistor connected from the PROG pin to ground. The battery charging current is 1200 times the current flowing out of the PROG pin. The required resistor value can be calculated from the charge current with following equation:

$$R_{PROG} = \frac{1200}{I_{CHG(MAX)}}$$

The instantaneous charging current may differ from above equation in trickle or constant voltage modes. The instantaneous charging current provided to the battery can be determined by monitoring the PROG pin voltage at any time with the following equation:

$$I_{CHG} = \frac{V_{PROG}}{R_{PROG}} \times 1200$$

Charge Termination

A charge cycle is terminated when the charge current falls to 1/10 the programmed value after the final float voltage is reached. This condition is detected by using an internal, filtered comparator to monitor the PROG pin. When the PROG pin voltage falls below 100mV for longer than T_{TERM} (1.8ms), charging is terminated. The charge current is shut off and the FP8102 enters standby mode, where the input supply current drops to 55uA. The FP8102 draws no current from the battery in standby mode. This feature reduces the charge and discharge cycles on the battery, further prolong the battery life.

Thermal Protection

An internal thermal feedback loop reduces the programmed charge current if the die temperature rises above a preset value of approximately 145°C. This feature protects the FP8102 from excessive temperature and allows the user to push the limits of the power handling capability of a given circuit board without risk of damaging the FP8102. The charge current can be set according to typical ambient temperature with the assurance that the charge will automatically reduce the current in worst case condition.

Battery Temperature Fault Monitoring

In the event of a battery over-temperature condition, the charging control will turn off the internal pass device and report a battery temperature fault on the TEMP pin. Inside the FP8102, two internal voltage references V_{TEMP-H} and V_{TEMP-L} are fixed at 80% $\times V_{CC}$ and 45% $\times V_{CC}$ respectively. As the TEMP pin voltage rises above V_{TEMP-H} or falls below V_{TEMP-L} , the FP8102 stops charging and indicates a fault condition. After the system recovers from a temperature fault, the device will resume charging operation. For applications that do not need to monitor the battery temperature, short the TEMP pin to the GND.

The values of R1 and R2 are set according to the battery temperature range and the value of thermal sensitive resistor. If the battery is equipped with NTC(Negative Temperature Coefficient) thermistor and the temperature monitor range is $T_L \sim T_H (T_L < T_H)$, then R_T , the thermistor resistance, decreases as temperature increases from T_L to T_H , means $R_{T_L} > R_{T_H}$.

The TEMP pin voltage can be calculated as:

$$V_{TEMP} = \frac{R2 // R_T}{R1 + R2 // R_T} \times V_{CC}$$

Thus, this V_{TEMP} decreases as the temperature increase from T_L to T_H .

To set proper R1 and R2 value for temperature protection, we set:

$$0.8 \times V_{CC} = V_{TEMPH} = \frac{R2 // R_{TL}}{R1 + R2 // R_{TL}} \times V_{CC} \text{ at } T_L$$

$$0.45 \times V_{CC} = V_{TEMPL} = \frac{R2 // R_{TH}}{R1 + R2 // R_{TH}} \times V_{CC} \text{ at } T_H$$

Where R_{TL} and R_{TH} are the thermistor resistances at T_L and T_H respectively.

So R1 and R2 can be derived as following:

$$R1 = \frac{R_{TL} R_{TH} (K_2 - K_1)}{(R_{TL} - R_{TH}) K_1 K_2} = \frac{R_{TL} R_{TH} \times 35}{(R_{TL} - R_{TH}) \times 36}$$

$$R2 = \frac{R_{TL} R_{TH} (K_2 - K_1)}{R_{TL} (K_1 - K_1 K_2) - R_{TH} (K_2 - K_1 K_2)} = \frac{R_{TL} R_{TH} \times 35}{R_{TL} \times 9 - R_{TH} \times 44}$$

where $K_1=0.45$ and $K_2=0.8$

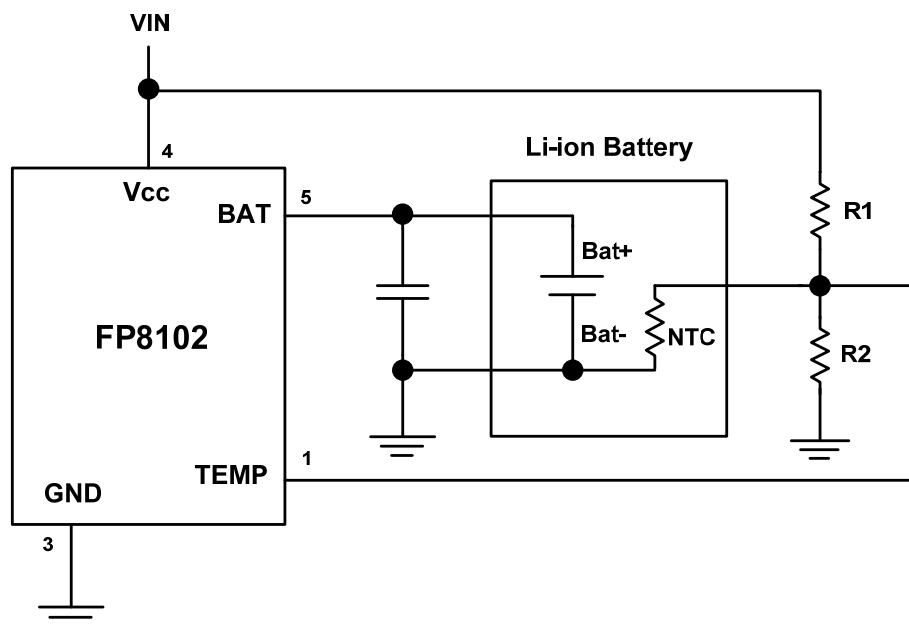

Under Voltage Lockout (UVLO)

An internal under voltage lockout circuit monitors the input voltage and keeps the charger in shutdown mode until V_{CC} rises above the under voltage lockout threshold. The UVLO circuit has a built-in hysteresis of 200mV. Furthermore, to protect against reverse current in the power MOSFET, the UVLO circuit force FP8102 to enter shutdown mode if V_{CC} falls to within 30mV of the battery voltage. If the UVLO comparator is tripped, the charger will not come out of shutdown mode until V_{CC} rises 100mV above the battery voltage.

This datasheet contains new product information. Feeling Technology reserves the rights to modify the product specification without notice. No liability is assumed as a result of the use of this product. No rights under any patent accompany the sales of the product.

Manual shutdown

At any point in the charge cycle, the FP8102 can be put into shutdown mode by removing R_{PROG} or put the EN pin to the low-level voltage. This reduces the battery drain current to about 2uA and the supply current to less than 55uA. A new charge cycle can be initiated by reconnecting the program resistor.

Automatic Recharge

Once the charge cycle is terminated, the FP8102 continuously monitors the voltage on the BAT pin using a comparator with a 1.8ms filter time (T_{RECHARGE}). A charge cycle restarts when the battery voltage falls below 4.05V (which corresponds to approximately 80% to 90% battery capacity). This ensures that the battery is kept at or near a fully charged condition and eliminated the need for periodic charge cycle initiations. $\overline{\text{CHRG}}$ output enters a strong pull-down state during recharge cycles.

Application Information

Stability Considerations

The constant-voltage mode feedback loop is stable without an output capacitor if a battery is connected to the charger output. With no battery present, an output capacitor is recommended to reduce ripple voltage. When using high value, low ESR ceramic capacitors, it is recommended to add a 1Ω resistor in series with the capacitor. No series resistor is needed if tantalum capacitors are used.

In constant-current mode, the PROG pin is in the feedback loop, not the battery. Because of the additional pole created by the PROG pin capacitance, capacitance on this pin must be kept to a minimum. With no additional capacitance on the PROG pin, the charger is stable with program resistor values as high as 25k. However, additional capacitance on this node reduces the maximum allowed program resistor. The pole frequency at the PROG pin should be kept above 100kHz. Therefore, if the PROG pin is loaded with a capacitance, C_{PROG} , the following equation should be used to calculate the maximum resistance value for R_{PROG} :

$$R_{PROG} \leq \frac{1}{2\pi \times 10^5 \times C_{PROG}}$$

Average, rather than instantaneous, battery current may be of interest to the user. For example, if a switching power supply operating in low current mode is connected in parallel with the battery, the average current being pulled out of the BAT pin is typically of more interest than the instantaneous current pulses. In such a case, a simple RC filter can be used on the PROG pin to measure the average battery current as shown in Figure 1. A 10K resistor has been added between the PROG pin and the filter capacitor to ensure stability.

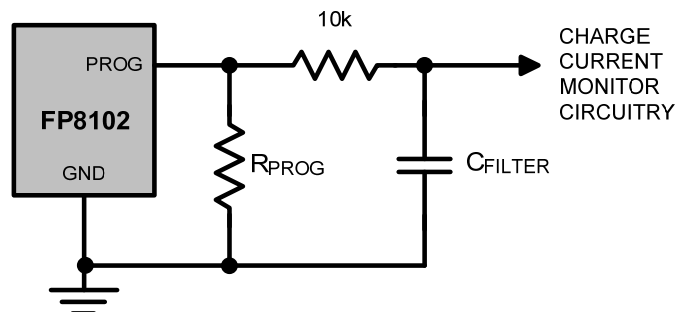

FIGURE 1

This datasheet contains new product information. Feeling Technology reserves the rights to modify the product specification without notice. No liability is assumed as a result of the use of this product. No rights under any patent accompany the sales of the product.

Power Dissipation

The conditions that cause the FP8102 to reduce charge current through thermal feedback can be approximated by considering the power dissipated in the IC. For high charge current, the FP8102 power dissipation is approximately:

$$P_D = (V_{CC} - V_{BAT}) \cdot I_{BAT}$$

Where P_D is the power dissipated, V_{CC} is the input supply voltage, V_{BAT} is the battery voltage and I_{BAT} is the charge current. It is not necessary to check any worst-case power dissipation scenarios because the FP8102 will automatically reduce the charge current to maintain the die temperature under 145°C approximately. The approximate ambient temperature at which the thermal feedback begins to protect the IC is:

$$\begin{aligned} T_A &= 145^\circ\text{C} - P_D \theta_{JA} \\ &= 145^\circ\text{C} - (V_{CC} - V_{BAT}) \cdot I_{BAT} \cdot \theta_{JA} \end{aligned}$$

For example: Consider an FP8102 operating from a 5V wall adapter providing 1A to a 3.6V Li-Ion battery. The ambient temperature above which the FP8102 will begin to reduce the 1A charge current is approximately:

$$\begin{aligned} T_A &= 145^\circ\text{C} - (5\text{V} - 3.6\text{V}) \cdot (1\text{A}) \cdot 50^\circ\text{C/W} \\ &= 145^\circ\text{C} - 1.4\text{W} \cdot 50^\circ\text{C/W} = 145^\circ\text{C} - 70^\circ\text{C} \\ &= 75^\circ\text{C} \end{aligned}$$

The FP8102 can be used above 75°C, but the charge current will be reduced to smaller than 1000mA. The approximate current at a given ambient temperature can be calculated:

$$I_{BAT} = \frac{145^\circ\text{C} - T_A}{(V_{CC} - V_{BAT}) \cdot \theta_{JA}}$$

Using the previous example with an ambient temperature of 90°C, the charge current will be reduced to approximately:

$$I_{BAT} = \frac{145^\circ\text{C} - 90^\circ\text{C}}{(5\text{V} - 3.6\text{V}) \cdot 50^\circ\text{C/W}} = \frac{55^\circ\text{C}}{70^\circ\text{C/A}} = 785\text{mA}$$

Furthermore, the voltage at the PROG pin will change proportionally with the charge current as discussed in the Programming Charge Current section. It is important to remember that FP8102 applications do not need to be designed for worst-case thermal conditions since the IC will automatically reduce power dissipation when the junction temperature reaches approximately 145°C.

Board Layout Considerations

Because of the small size of the SOP8/MSOP8, it is very important to apply a good thermal conduction PC board layout to maximize the available charge current. The thermal path for the heat generated by the IC is from the die through the package leads (especially the ground lead) to the PC board copper. The PC board copper is the heat sink. The copper pads footprint should be as large as possible and expand out to large copper areas to spread and dissipate the heat to the surrounding ambient. Feed-through vias to inner or backside copper layers are also useful in improving the overall thermal performance of the charger. Other heat source on the board, not related to the charger, must also be considered when designing a PC board layout because they will affect overall temperature rise and the maximum charge current.

Vcc Bypass Capacitor

Many types of capacitors can be used for input bypassing, however, caution must be exercised when using multilayer ceramic capacitors. Because of the self-resonant and high Q characteristics of some types of ceramic capacitors, high voltage transients can be generated under some start-up conditions, such as connecting the charger input to a live power source. Adding a 1.5Ω resistor in series with an X5R ceramic capacitors (as shown in Figure 2) will minimize start-up voltage transients.

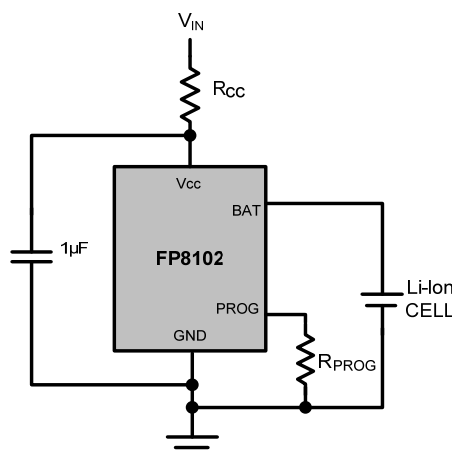

FIGURE 2

This datasheet contains new product information. Feeling Technology reserves the rights to modify the product specification without notice. No liability is assumed as a result of the use of this product. No rights under any patent accompany the sales of the product.

USB and Wall Adapter Power

Although the FP8102 allows charging from a USB port, a wall adapter can also be used to charge Li-ion batteries. Figure 3 shows an example of how to combine wall adapter and USB power inputs. A P-channel MOSFET, MP1, is used to prevent back conducting into the USB port when a wall adapter is present. The schottky diode, D1, is used to prevent USB power loss through the 10k Ω pull-down resistor.

Typically, a wall adapter can supply significantly more current than the 500mA-limited USB port. Therefore, an N-channel MOSFET, MN1, and an extra program resistor are used to increase the charge current to 600mA when the wall adapter is present.

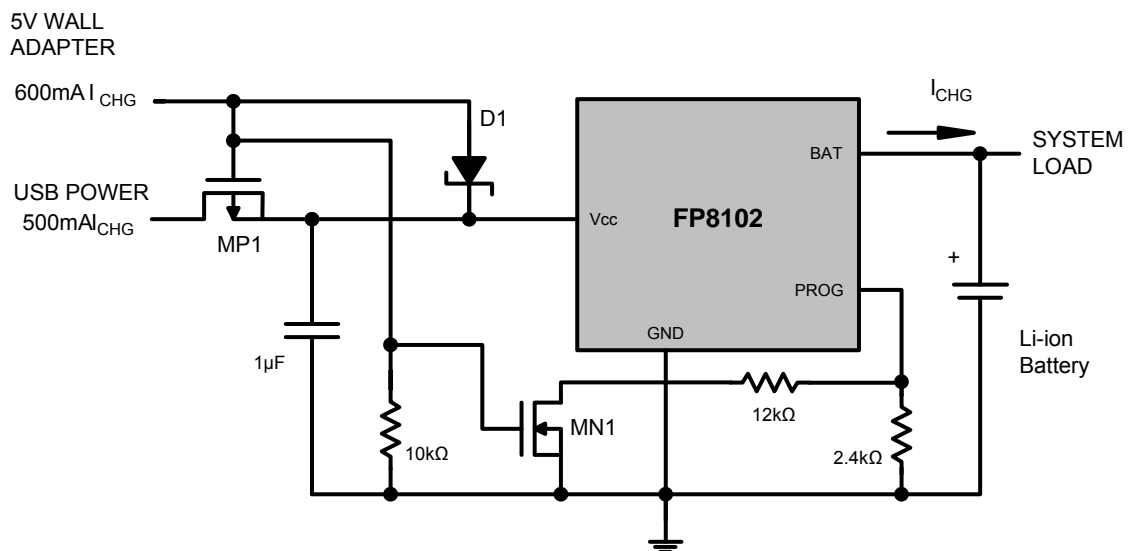
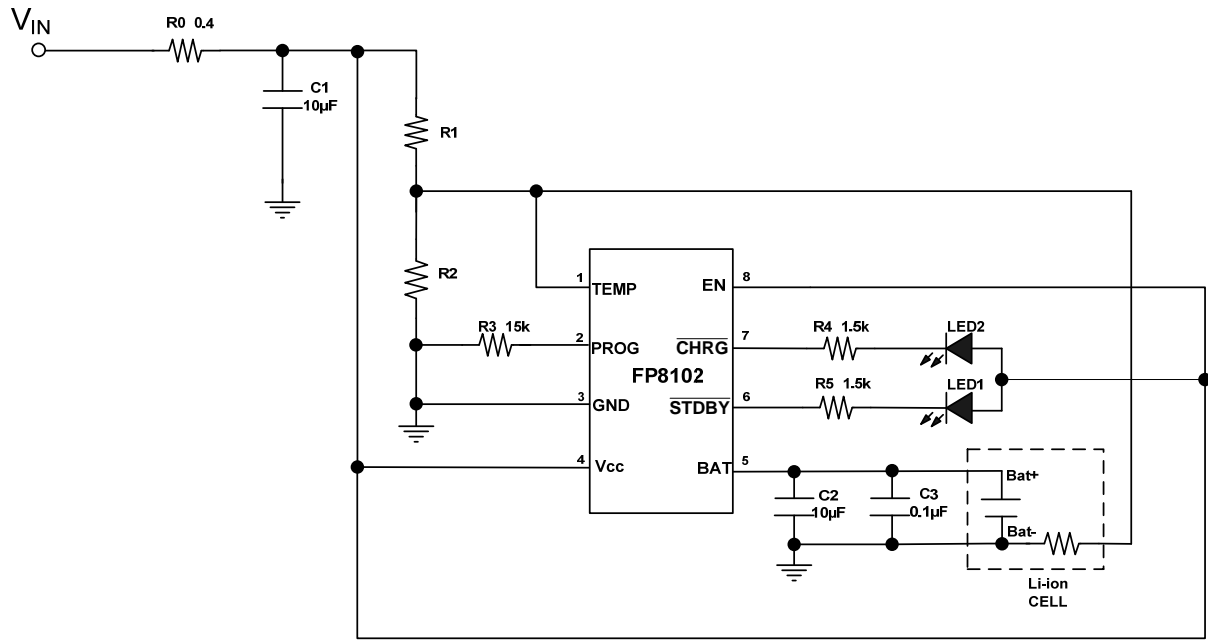

FIGURE 3

Typical Application



This datasheet contains new product information. Feeling Technology reserves the rights to modify the product specification without notice. No liability is assumed as a result of the use of this product. No rights under any patent accompany the sales of the product.

Package Outline

SOP-8L (EP)

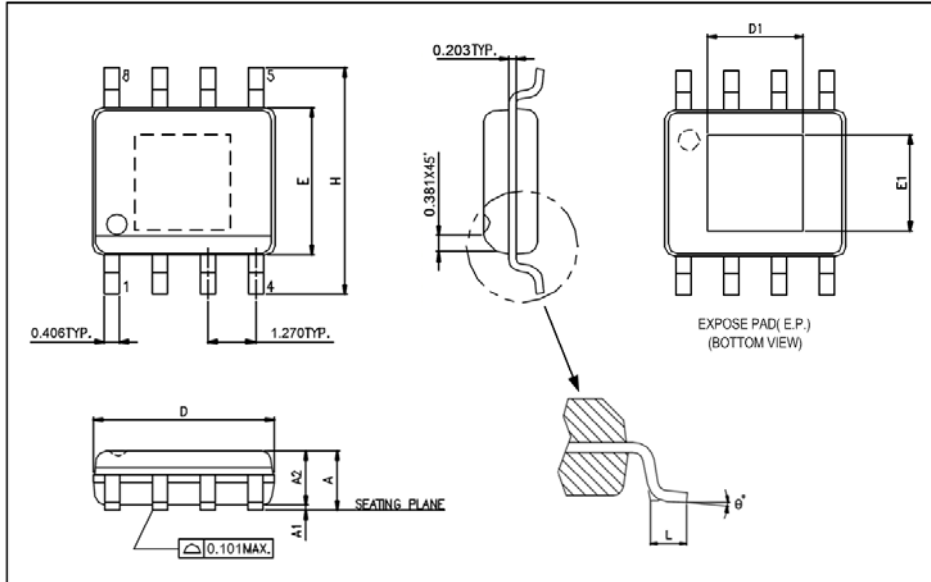

Symbols	Min. (mm)	Max. (mm)
A	1.346	1.752
A1	0.050	0.152
A2		1.498
D	4.800	4.978
E	3.810	3.987
H	5.791	6.197
L	0.406	1.270
θ°	0°	8°

Exposed PAD Dimensions:

Symbols	Min. (mm)	Max. (mm)
E1		2.184 REF
D1		2.971 REF

Note:

1. JEDEC Outline : N/A
2. Dimensions "D" does not include mold flash, protrusions or gate burrs mold flash
3. Protrusions and gate burrs shall not exceed .15mm (.006in) per side.
Dimensions "E" does not include inter-lead flash or protrusions inter-lead flash and protrusions
4. Shall not exceed 25mm (.010in) per side.

This datasheet contains new product information. Feeling Technology reserves the rights to modify the product specification without notice. No liability is assumed as a result of the use of this product. No rights under any patent accompany the sales of the product.

MSOP-8L (EP)

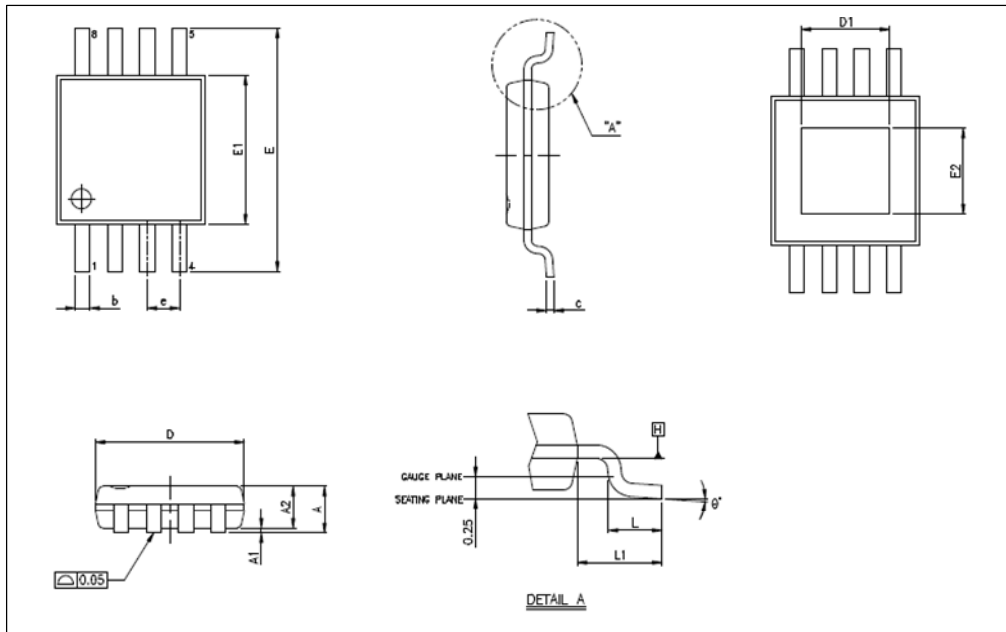

Symbols	Min. (mm)	Max. (mm)
A	-	1.10
A1	0.00	0.15
A2	0.75	0.95
b	0.22	0.38
c	0.08	0.23
D	3.00 BSC.	
E	4.90 BSC.	
E1	3.00 BSC	
e	0.65 BSC	
L	0.40	0.80
L1	0.95 REF	
θ°	0	8

Exposed PAD Dimensions:

Symbols	Min. (mm)	Max. (mm)
E2	1.715 REF	
D1	1.600 REF	

This datasheet contains new product information. Feeling Technology reserves the rights to modify the product specification without notice. No liability is assumed as a result of the use of this product. No rights under any patent accompany the sales of the product.

Note:

1. JEDEC Outline : MO-187 AA
2. Dimensions "D" does not include mold flash , protrusions or gate burrs. Mold flash ,protrusions and gate burrs shall not exceed 0.15 per side.
3. Dimensions "E1" does not include interlead flash ,or protrusions.
Interlead flash or protrusions shall not exceed 0.25 pre side.
4. Dimensions "b" does not include dambar protrusions. Allowable dambar protrusions shall be 0.08 mm total in excess of the "b" dimension at maximum material condition. Dam bar cannot be located on the lower radius of the foot. Minimum spec between protrusion and adjacent lead is 0.07mm.