

Advanced Linear Charger IC for Lithium-ion and Lithium-polymer Battery

FEATURES

- 4.5V to 12V input voltage range
- Ideal for single (4.2V) Li-ion or Li-polymer battery packs
- Better than $\pm 1\%$ voltage regulation accuracy
- Adjustable charge current during constant current charge
- Constant voltage charge
- Automatic battery recharge
- Charge status output with LED
- Charge termination by minimum current
- Battery Short Indication
- Automatic low-power sleep mode when V_{CC} is removed or when the voltage supply is lower than the battery voltage
- Few external components
- Small package: 8-pin SOP or 8-pin MSOP

APPLICATIONS

- Handheld devices
- Cellular phones
- PDAs

DESCRIPTION

VA7208 is an advanced Lithium-Ion and Lithium-Polymer linear charger IC designed for cost-sensitive and compact portable electronics. It

combines high-accuracy current, voltage regulation, charge termination, and charge status indication in a single 8-pin IC. It is the best suitable device to be used in PDA, mobile phone, and other portable devices.

VA7208 monitors the battery charging status by detecting the battery voltage. VA7208 charges the battery in three phases: conditioning, constant current and constant voltage.

If the battery voltage (V_{BAT}) is below the preconditioning voltage threshold (V_{MIN}), VA7208 precharges the battery using a low current. When the battery voltage reaches V_{MIN} , VA7208 applies a constant current to charge the battery. An external sense resistor controls the current. The constant current charging continues until the battery voltage reaches the voltage regulation threshold (V_{REG}). And then VA7208 enters the constant voltage charging phase. The accuracy of the voltage regulation is better than $\pm 1\%$ over the operating temperature and supply voltage range. Under the condition, the charging current gradually decreases. Charge stops when the current tapers to the charge termination threshold, I_{TERM} . VA7208 monitors the battery voltage continuously and enters a new cycle of charging if the battery's voltage falls below the recharge voltage threshold (V_{RECHG}).

VA7208 is available in a small 8-pin SOP package or 8-pin MSOP package.

FUNCTIONAL BLOCK DIAGRAM

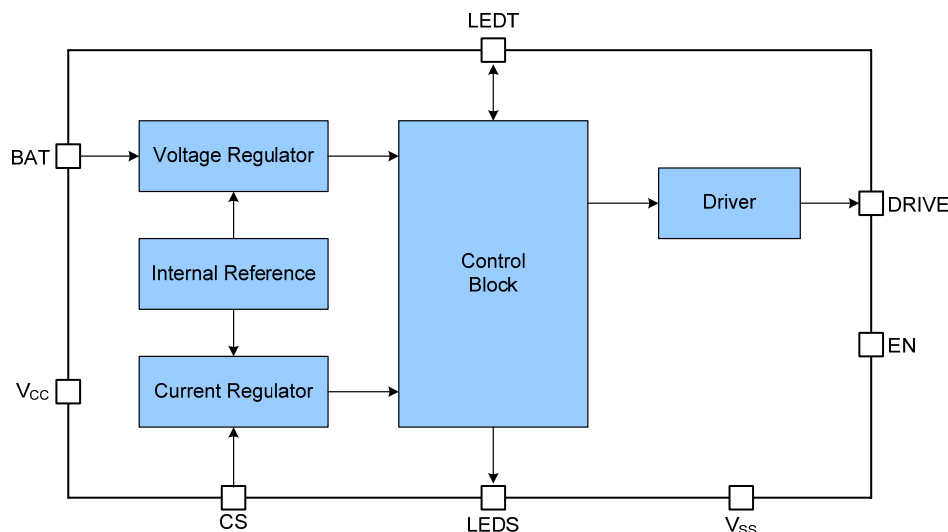

Figure 1 Functional Block Diagram

ORDERING INFORMATION

[Table 1] Ordering Information

MODEL	OUTPUT VOLTAGE	RECHARGING VOLTAGE	PACKAGE	PIN COUNT	REEL OR TUBE
VA7208MKR	4.2V	4.075V	SOP	8	reel
VA7208MKT	4.2V	4.075V	SOP	8	tube
VA7208MNR	4.2V	4.075V	MSOP	8	reel
VA7208MNT	4.2V	4.075V	MSOP	8	tube

PIN CONFIGURATIONS

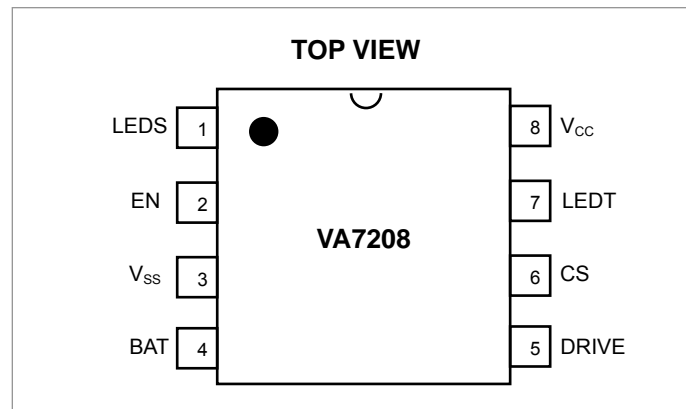

Figure 2 VA7208 Pin Configurations (Not to scale)

PIN DESCRIPTION

[Table 2] Pin Description

NAME	ORDER	I/O	FUNCTION
LEDS	1	O	Charge Status Output During charging, this pin is pulled down to V_{SS} . When charging is completed, this pin appears as a high-impedance state. Under the condition of abnormal battery operation, a 50% duty-cycle 4Hz pulse is generated. This pin can be connected to the LED diode via a resistor.
EN	2	I	Enable Input Turn on the IC when the voltage on this pin is "high", and turn off when "low".
V_{SS}	3	PWR	Connected to Ground
BAT	4	I	Battery Voltage Sense Input This pin is wired to the positive side of the battery. Apply a 10 μ F capacitor between this pin and GND.
DRIVE	5	O	External Pass Transistor Drive Output This output drives an external pass-transistor (PNP or P-Channel MOSFET) for current and voltage regulation.
CS	6	I	Current-Sense Input Battery current is sensed via the voltage developed on this pin by an external sense resistor. The external resistor can be placed between the positive terminal of the power supply and the emitter (PNP transistor) or source (PMOS transistor).
LEDT	7	O	Charge Termination Status Output During charging, this pin appears as a high-impedance state. After charging is terminated, this pin is pulled down to V_{SS} and it can be used as a charging termination indicator.
V_{CC}	8	PWR	Power Supply Input This pin is connected to the positive side of a power supply. Apply a 10 μ F capacitor between V_{CC} and V_{SS} .

ABSOLUTE MAXIMUM RATING

V_{CC} 、LEDT、EN、LEDS Input Voltage -0.3V~18V	Total Power Dissipation, P_D ($T_A=25^\circ\text{C}$)
CS、DRIVE Input Voltage-0.3V~ $V_{CC}+0.3\text{V}$	SOP8 150°C/W
BAT Input Voltage..... -0.3V~7V	MSOP8 130°C/W
Operating Ambient Temperature Range, T_A -40°C~+85°C	Storage Temperature Range..... -65°C~150°C
Junction Temperature 150°C	Lead Temperature (Soldering, 10 seconds) ..260°C



Note: Stresses beyond those listed under “absolute maximum ratings” may cause permanent damage to the device. These are stress ratings only and functional operation of the device at these or any other conditions beyond the recommended operating condition are not implied. Exposure to absolute-maximum-rated conditions for extended periods may affect device reliability.

ELECTRICAL CHARACTERISTICS

($V_{CC} = 5\text{V}$, $T_A = 25^\circ\text{C}$ unless otherwise specified. The operating temperature with Mark “◆” is: $-40^\circ\text{C} \leq T_A \leq 85^\circ\text{C}$)

[Table 3] Electrical Specification

PARAMETER	SYMBOL	TEST CONDITION		MIN	TYP	MAX	UNIT
Power Supply Voltage	V_{CC}		◆	4.5		12	V
Power Supply Current	I_{CC}	$V_{CC}=5\text{V}$	◆		1	3	mA
		$V_{CC}=12\text{V}$	◆		2		mA
Under Voltage Lockout	V_{UVLO}	V_{CC} rising	◆	2.8	3.0	3.2	V
Sleep Current	I_{SLEEP}	V_{CC} floating, $V_{BAT}=4.2\text{V}$	◆			1	μA
Voltage Regulation Threshold	V_{REG}	$V_{CC}=V_{CS}=V_{LEDT}$		4.168	4.200	4.232	V
			◆	4.158	4.200	4.242	V
Line Regulation		$V_{CC}=5\text{V}\sim 12\text{V}$			0.05		%
Recharge Voltage Threshold	V_{RECHG}			$V_{REG}-0.175$	$V_{REG}-0.125$	$V_{REG}-0.070$	V
Current Regulation Threshold	V_{CHG}	CS1 Relative to V_{CC} (see note 1)	◆	135	150	165	mV
Precharge Regulation threshold	V_{PRECHG}	CS1 Relative to V_{CC}		10	18	28	mV
Termination Regulation Threshold	V_{TERM}	CS1 Relative to V_{CC}		8	15	22	mV
Preconditioning Voltage Threshold	V_{MIN}	Hystersis=100mV		2.94	3.00	3.06	V
EN High Level	V_{ENH}	$V_{CC}=3.0$ to 12V		1.3			V
EN Low Level	V_{ENL}	$V_{CC}=3.0$ to 12V				0.5	V
EN bias current	I_{EN}	$V_{EN}=0$ to 12V		-1		1	μA
Sleep Mode Entry Voltage Threshold	$V_{SLEEPEXIT}$	$V_{CC}-V_{BAT}$			50		mV
Sleep Mode Exit Voltage Threshold	$V_{SLEEPEXIT}$	$V_{CC}-V_{BAT}$			100		mV
Drive Pin Pull-up Resistance		$V_{BAT}=4.5\text{V}$			5		K Ω
Drive Pin High Output Voltage		$V_{CC}=12\text{V}, V_{BAT}=4.5\text{V}$	◆	11.5			V
Drive Pin Sink Current		$V_{BAT}=3.6\text{V}, V_{DRIVE}=1\text{V}$	◆	30			mA

PARAMETER	SYMBOL	TEST CONDITION	MIN	TYP	MAX	UNIT
Battery Short Indication Threshold	V_{BSC}		0.4	0.8	1.2	V
LEDS Output Pulse Frequency		$V_{BAT} < V_{BSC}$	2	4	6	Hz
LEDS Output Pulse Duty Cycle		$V_{BAT} < V_{BSC}$		50		%
LEDS Input Current		$V_{BAT} > V_{RECHG}$			1	μA
LEDT Input Current		$V_{BAT} < V_{RECHG}$			1	μA
LEDS,LEDT Output Sink Current		$V_{LEDS} = V_{LEDT} = 0.3V$	10			mA
BAT Input Current		$V_{BAT} = 0$ to 4.5V		5.0	10	μA
BAT External Cap			4.7		47	μF
CS Input Current		$V_{BAT} = 0$ to 3.6V			1	μA



Note: 1. Unless otherwise specified, all voltages are referred to V_{SS} .
 2. Please use application circuit schematic in figure 3 and figure 5.

TYPICAL APPLICATION SCHEMATIC

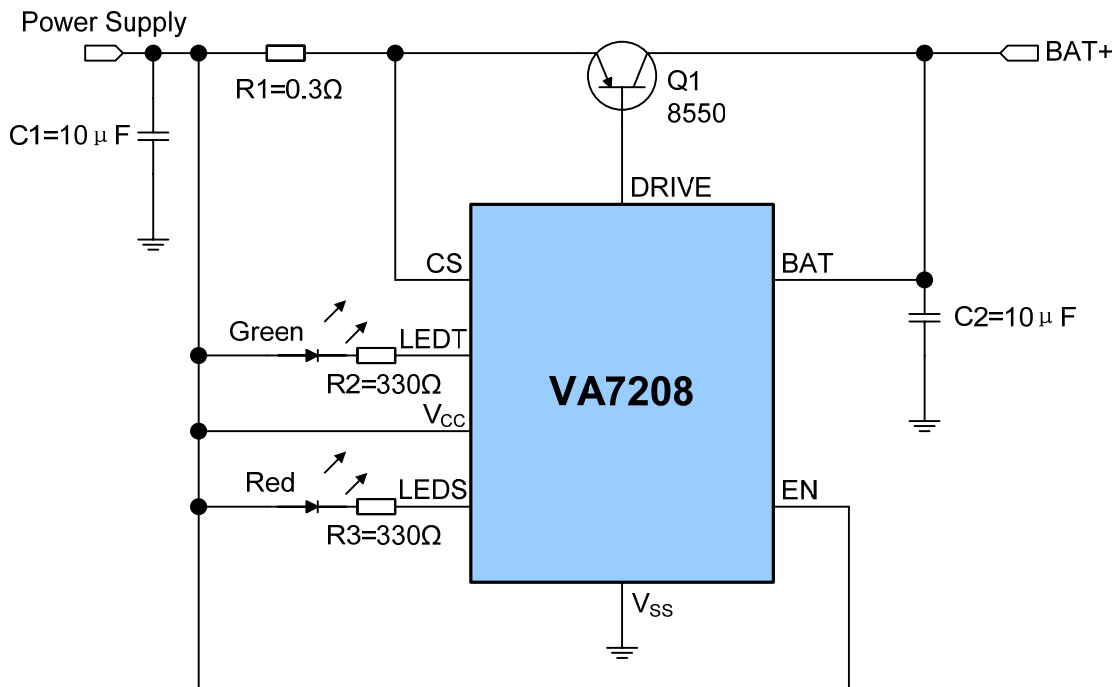

Figure 3 Li-ion and Li-Polymer Charger Using a PNP

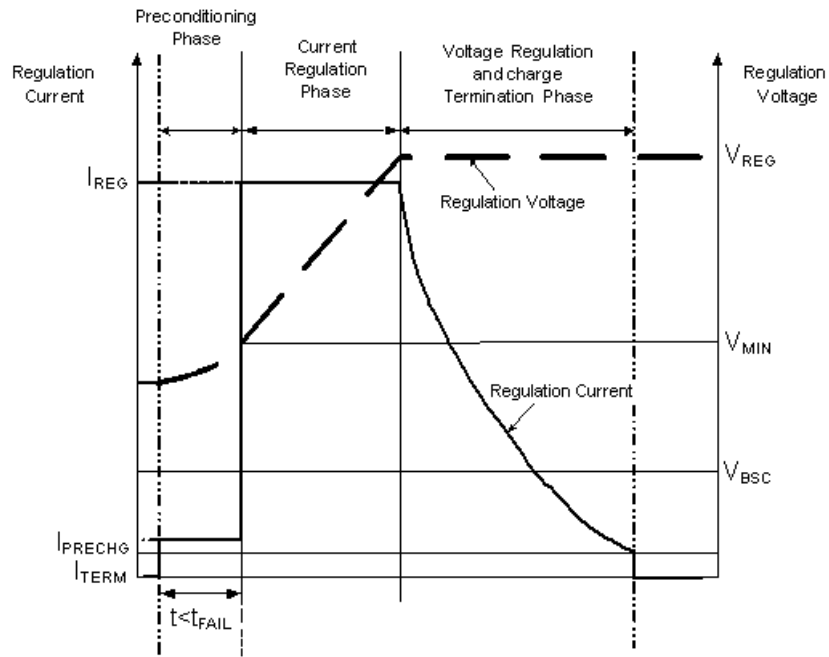

Figure 4 Typical Charge Profile

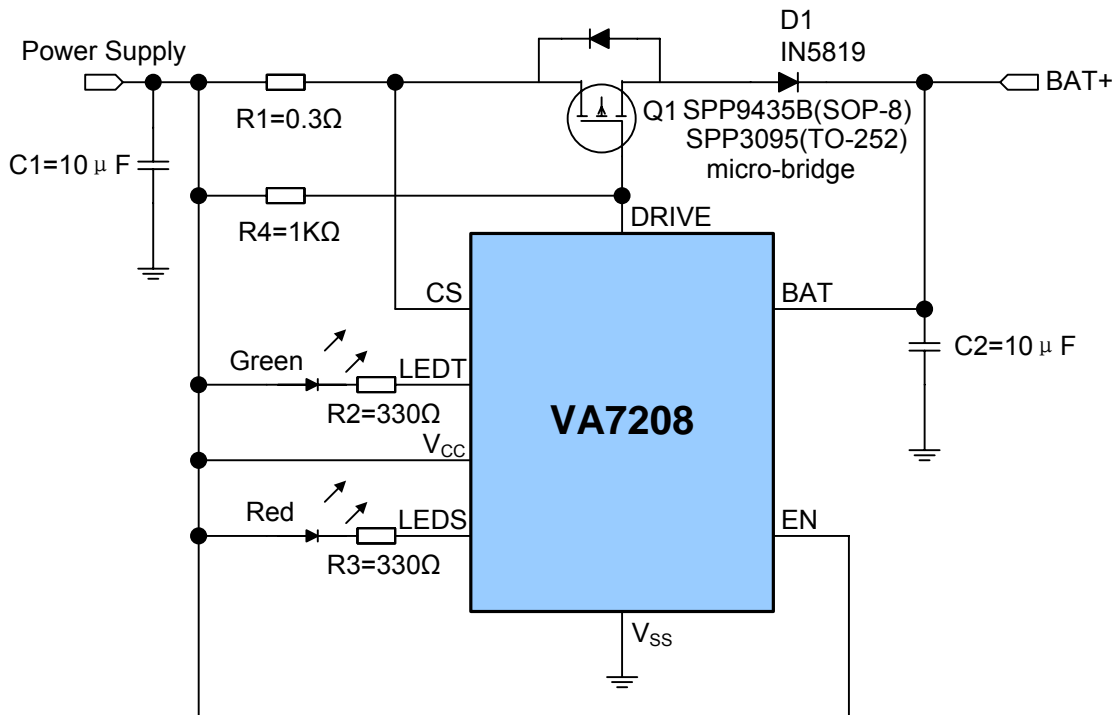

Figure 5 Li-ion and Li-Polymer Charger Using a PMOS

FUNCTION DESCRIPTION

Qualification and Precharge

A battery charge cycle is started if any of the following situations are met:

- The power is supplied ($V_{CC} > V_{UVLO}$), and a battery is inserted ($V_{BAT} < V_{RECHG}$);
- A battery is already present ($V_{BAT} < V_{REG}$) and the power is supplied ($V_{CC} > V_{UVLO}$).

Charge qualification is based on the battery voltage. If the battery voltage is lower than the precharge threshold (V_{MIN}), VA7208 conditions the battery by using precharge current. The precharge current can be set by the following formula:

$$I_{PRECHG} = \frac{V_{PRECHG}}{R_1}$$

The precharge current is much smaller than the regulation current. Because when the battery voltage level (V_{BAT}) is very low, a high charge current can cause a safety hazard.



Note: In scenario (a), if the battery voltage (V_{BAT}) is higher than the recharge voltage threshold (V_{RECHG}), VA7208 can not immediately get into the charging mode until $V_{BAT} < V_{RECHG}$, the charger indication red LED and green LED remain off. In scenario (b), if V_{BAT} is lower than V_{REG} , regardless of V_{BAT} is higher than V_{RECHG} , VA7208 can immediately start charging, if V_{BAT} is higher than V_{REG} , VA7208 will not get into the charging mode and the charger indication red LED and green LED will both off.

Current Regulation Phase

When the battery voltage reaches V_{MIN} , VA7208 enters the current regulation phase. The charging current is determined by the following formula:

$$I_{REG} = \frac{V_{REG}}{R_1}$$

Voltage Regulation Phase

During the battery charging in the current regulation phase, the battery voltage (V_{BAT}) increases gradually. When V_{BAT} reaches V_{REG} , VA7208 gets into the voltage regulation phase. In this phase, V_{BAT} is equal to V_{REG} , and the charge current decreases gradually.

Charge Termination

During the battery charging in the voltage regulation phase, the charge current gradually decreases until

$I_{TERM} = V_{TERM} / R_1$. And then, the battery charging terminates and the charge current becomes zero.

Charge Status Indication

VA7208 has two charge indication pins: LEDS and LEDT.

The LEDS pin indicates the charging status. This pin is connected to V_{CC} via a red LED and a current limit resistor. During the battery charging, the LEDS pin is pulled low and the red LED is turned on. Under the abnormal condition ($V_{BAT} < V_{BSC}$), the LEDS pin outputs a 50% duty cycle 4Hz pulse and cause red LED to blink. When the battery charging is terminated, the LEDS pin turns to a high impedance state. The red LED is turned off.

The LEDT pin indicates the charge termination. This pin is connected to V_{CC} via a green LED and a current limit resistor. During the battery charging, the voltage at the LEDT pin is close to V_{CC} and the green LED is turned off. When the battery charging is terminated, the LEDT pin is pulled low. The green LED is turned on.

When there is no battery connected to BAT pin, LEDS and LEDT pin both in high impedance state, and the red LED and green LED will both off.

Low-Power Sleep Mode

VA7208 enters sleep mode if V_{CC} falls below the voltage of the BAT pin or V_{CC} is removed. This feature prevents the battery from draining during the absence of V_{CC} .

Recharge

If the charging is terminated, the battery voltage (V_{BAT}) should be equal to V_{REG} . The red LED is turned off and the green LED is turned on to indicate the charge termination. When V_{BAT} falls to below the recharge threshold voltage (V_{RECHG}), VA7208 automatically enters the recharge phase and light up the red LED and turn off the green LED to indicate a new charge cycle.

ENABLE/DISABLE OPERATION

The operating status of VA7208 can be set by controlling the voltage on the EN pin. The chip turns off when the voltage on the EN pin is lower than V_{ENL} , and turns on automatically when the voltage is higher than V_{ENH} . In shut down mode, the chip need extremely low current and the battery only draining extremely low current (<1uA). If this feature is not to be used, the EN pin should be connected to V_{CC} to keep the IC work at all times.

STATE CONVERSION DIAGRAM

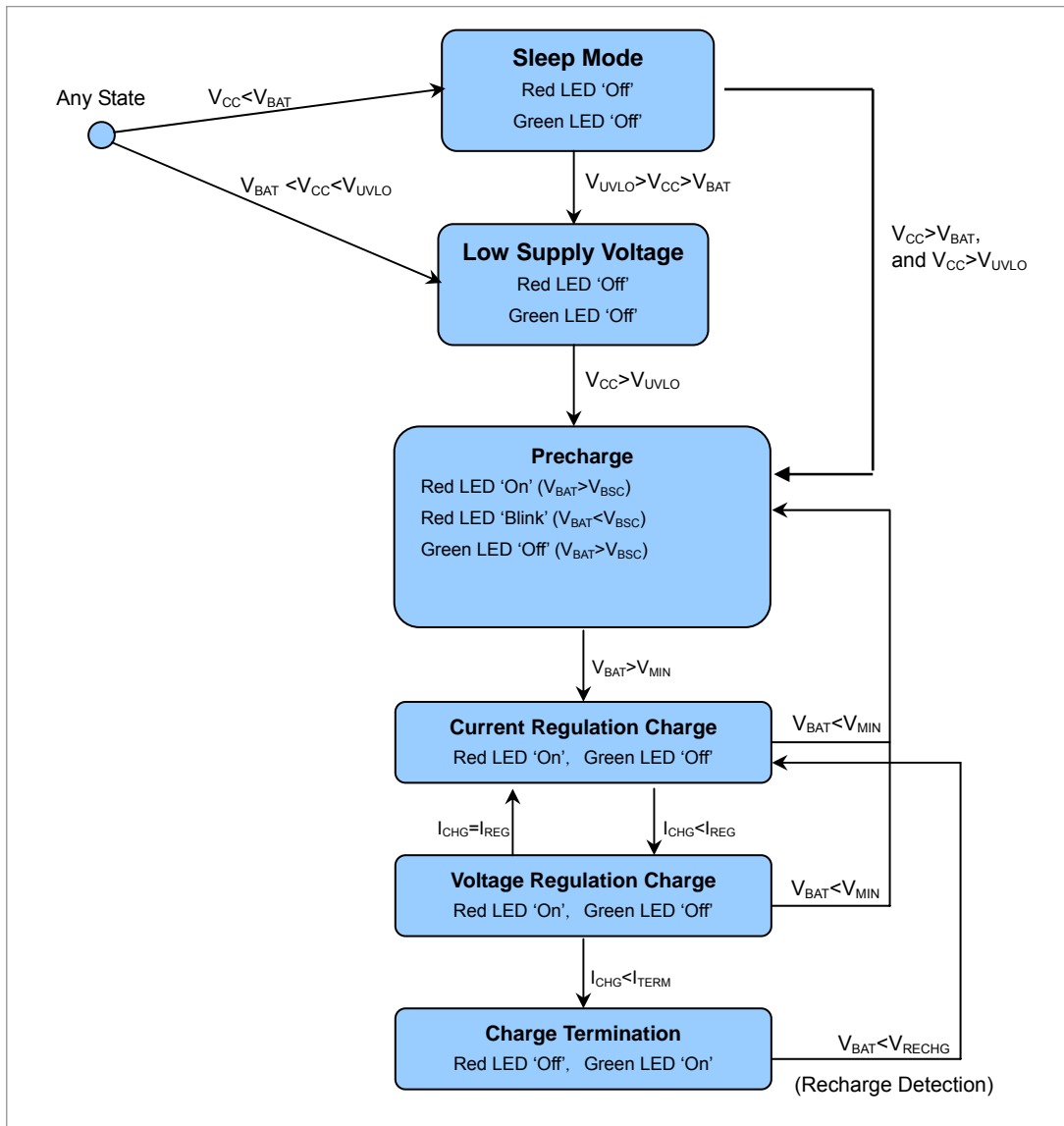

Figure 6 State Conversion Diagram

APPLICATION NOTES

Selection of PNP transistor

To select a PNP bipolar transistor, we consider the maximum allowed current I_{CM} , maximum allowed power dissipation P_D , Collector-Emitter breakdown voltage BV_{CEO} , β and theta θ_{JA} etc. The following example shows the method of determining each parameter.

Assuming there is no blocking diode D1, $V_{CC}=6V$ and $R1=0.3\Omega$, then the constant-current charging current is: $I_{REG}=V_{CSREG}/R1=150mV/0.3\Omega=0.5A$.

a) Selection of BV_{CEO}

At the beginning of charging, the voltage drop across the collector-emitter is the largest, and $V_{CE}=V_{CS}-V_{BAT}$. At the beginning, V_{BAT} is very small, even smaller than V_{BSC} , so V_{CS} is very close to V_{CC} . To prevent the transistor from being damaged, a small margin is used on breakdown voltage. It is generally required to have BV_{CEO} larger than V_{CC} . In this example, we choose $BV_{CEO}>15V$.

b) Selection of P_D

The voltage drop across collector-emitter is the largest at the beginning of charging, but the power dissipation isn't large that much because the precharging current is very small. When the battery gets into the constant-current charging, the power dissipation reaches the maximum. At this moment, the voltage drop across the collector-emitter is:

$$V_{CE}=V_{CS}-V_{BAT}=6-0.15-3.0=2.85V;$$

$$\text{Collector current } I_C=I_{REG}=0.5A.$$

Therefore the power dissipation P_D is:

$$P_D=V_{CE} \times I_C \dots \dots \dots (1)$$

$$=2.85 \times 0.5=1.425W$$

c) Selection of theta θ_{JA}

Theta θ_{JA} is related to the package size of the transistor. Properly selecting θ_{JA} will keep the junction temperature below manufacturer's recommended value T_{JMAX} when the power dissipation is the maximum. Assuming the maximum junction temperature is $T_{JMAX}=150^\circ C$, at the room temperature $T_A=40^\circ C$, theta θ_{JAMAX} is:

$$\theta_{JAMAX}=(T_{JMAX}-T_A)/P_D \dots \dots \dots (2)$$

$$=(150^\circ C-40^\circ C)/1.425W=77.2^\circ C/W$$

Likewise, we need to select the transistor whose θ_{JA} is smaller than θ_{JAMAX} with 10% margin. In this example, we choose a PNP transistor with theta $\theta_{JA}=60^\circ C/W$ in SOT223 package.

d) Selection of maximum allowed current I_C

In the constant current charging state, the maximum current conducts through the transistor. To leave 50% margin, we can select the following value:

$$I_C=I_{REG} \times 150\% \dots \dots \dots (3)$$

$$=0.5 \times 150\%=0.75A$$

e) Selection of β

We can use the maximum collector current I_{CMAX} and its corresponding base current I_B to determine the value of β . In this example, $I_{CMAX}=I_{REG}$ and I_B are the transistor's forcing current. If choose $I_B=30mA$, β can be calculated:

$$\beta=I_{CMAX}/I_B \dots \dots \dots (4)$$

$$=0.5/0.03=17$$

β is normally larger than 17, so it is easy to find a transistor that meets the condition.

From the a-e steps above, we can select the transistor 8850 with TO-92 package.

Selection of P-channel MOSFET

To select a PMOS, some parameters such as maximum allowed drain current I_D , maximum allowed power dissipation P_D , theta θ_{JA} , source-drain breakdown voltage V_{DS} and gate-source driving voltage V_{GS} are considered. The following example shows how to determine these parameters.

In this example, assuming the blocking diode D1 exists, $V_{CC}=6.5V$, $R1=0.3\Omega$ and the constant-current charging current is $I_{REG}=0.5A$

a) Selection of V_{DS}

At the beginning of the charging, the voltage drop across PMOS source-drain is the largest and $V_{DS}=V_{CC}-V_{D1}-V_{R1}-V_{BAT}$ (V_{D1} is forward voltage drop across the blocking diode D1, the value is about 0.7V; V_{R1} is the voltage drop across the resistor R1 and the value is very small as well). V_{DS} should be larger than V_{CC} , so we can select $V_{DS}>15V$.

b) Selection of P_D

When VA7208 enters the constant-current charging state, the PMOS has the largest power dissipation. The source-drain voltage is:

$$V_{DS}=V_{CC}-V_{D1}-V_{R1}-V_{BAT}$$

$$=6.5-0.7-0.15-3.0=2.65V;$$

$$\text{Drain current } I_D=I_{REG}=0.5A$$

The power dissipation P_D is:

$$P_D=V_{DS} \times I_D \dots \dots \dots (5)$$

$$=2.65 \times 0.5=1.325W$$

c) Selection of theta θ_{JA}

The maximum allowed theta θ_{JAMAX} is:

$$\theta_{JAMAX}=(T_{JMAX}-T_A)/P_D$$

$$=(150^\circ C-40^\circ C)/1.325W=83^\circ C/W$$

Therefore, it's ample to select a PMOS transistor with TSSOP-8 package that has a theta θ_{JA} of $70^\circ C/W$.

d) Selection of maximum allowed current I_D

The maximum allowed current is the same with the current when using PNP transistor: $I_D=0.75A$

e) Gate-source driving voltage V_{GS}

The voltage across gate-source of the PMOS is:

$$V_{GS} = V_{CC} - (V_{D1} + V_{R1} + V_{DRIVE})$$

When DRIVE terminal of VA7208 outputs low voltage V_{OL} ($\sim 1.0V$), the PMOS transistor is turned on. In the constant-current charging state, V_{R1} is at the maximum value and V_{GS} is at the minimum:

$$V_{GSMIN} = V_{CC} - (V_{D1} + V_{R1} + V_{OL}) \dots\dots\dots (6)$$

$$= 6.5 - (0.7 + 0.1 + 1.0) = 4.65V$$

When we select a PMOS, V_{GS} at I_{REG} should be smaller than V_{GSMIN} and the threshold voltage must be smaller than V_{GSMIN} .

Likewise, from the above steps a-e, we can select the PMOS needed.

Blocking Diode D1

A blocking diode D1 is used to prevent the battery reverse discharging, when the power supply voltage, V_{CC} , is lower than the battery voltage V_{BAT} . In the actual application, first determine if the diode D1 is required or not.

Normally, the power supply will have very huge reversing resistance, so the battery discharge current cause by power supply is very small even if V_{CC} is zero. But if there is another load at V_{CC} terminal, the blocking diode D1 will become necessary to prevent the battery to draining current to the load.

Therefore, we can decide whether to use the blocking diode based on the actual application circuit and its specific requirement.

PCB layout

When layout PCB, R1 should be put between V_{CC} and VA7208's CS pin and the connection line to R1 from both sides should be as short as possible. C1 should be placed tightly with R1 and C2 should be placed tightly with VA7208. Every effort should be made to ensure the lines between C1, R1, Q1, C2 and VA7208 as short and wide as possible.

For best performance, it is suggested to minimize the area of PCB. Of course, this is also required for small form factor, reducing manufacturing cost.

PACKAGE DIMENSION

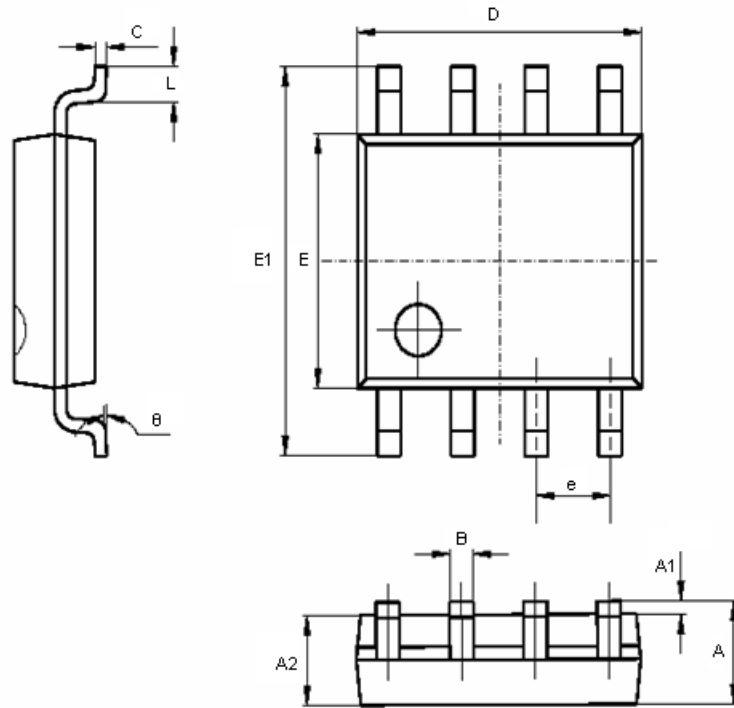

Figure 7 VA7208 8-Pin SOP Package

[Table 4] Physical dimensions in figure 7 (Unit:mm)

SYMBOL	MIN	MAX
A	1.350	1.750
A1	0.100	0.250
A2	1.360	1.650
B	0.330	0.510
C	0.190	0.250
D	4.780	5.000
E	3.800	4.000
E1	5.800	6.300
e	1.270 (TYP)	
L	0.400	1.270
θ	0°	8°

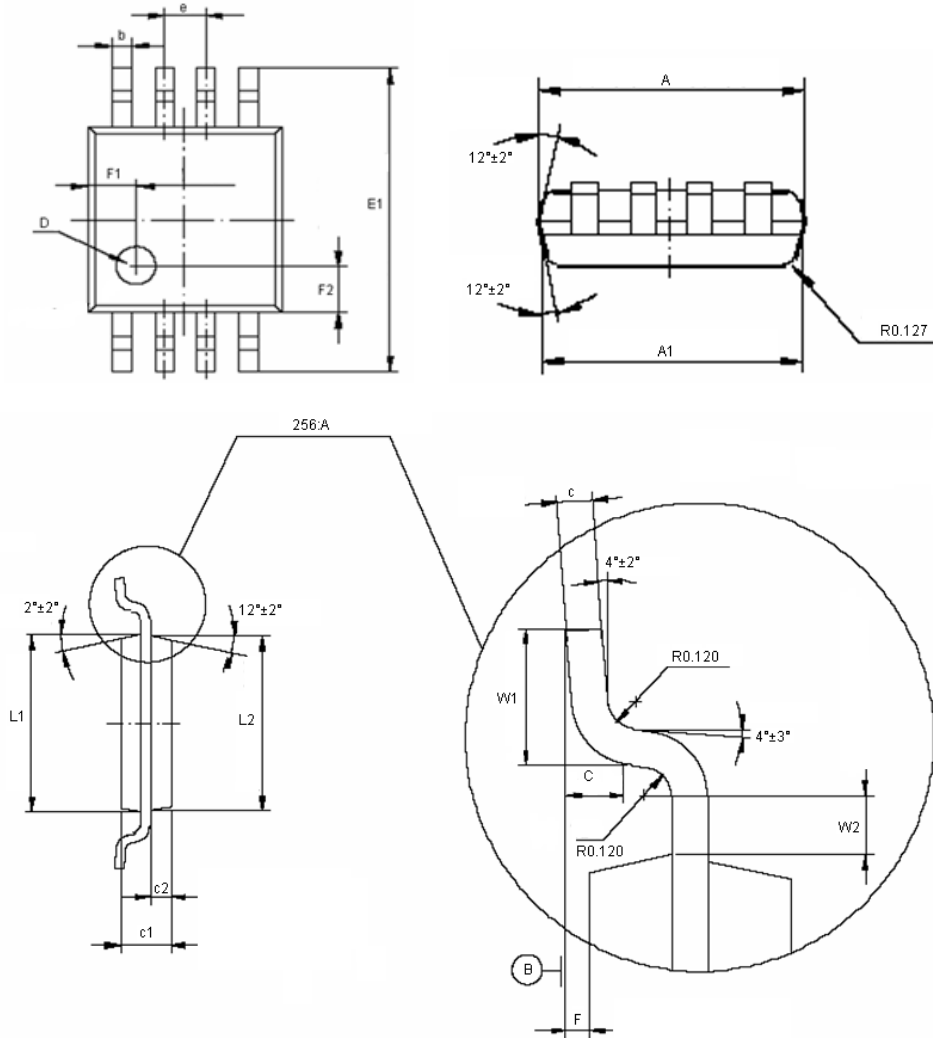

Figure 8 VA7208 8-Pin MSOP Package

[Table 5] Physical dimensions in figure 8 (Unit:mm)

SYMBOL	MIN	MAX
A	2.950	3.050
A1	2.890	2.990
b	0.300 (TYP)	
c	0.152 (TYP)	
c1	0.800	0.900
c2	0.324	0.374
C	0.250 (TYP)	
D	Φ0.650 (TYP)	
e	0.500 (TYP)	
E1	4.800	5.000
F	0.050	0.150
F1	0.750 (TYP)	
F2	0.750 (TYP)	
L1	2.950	3.050
L2	2.890	2.990
W1	0.523	0.623
W2	0.200	0.250