

isc Silicon NPN Darlington Power Transistor

BD649

DESCRIPTION

- Collector-Emitter Breakdown Voltage-
: $V_{(BR)CEO} = 100V(\text{Min})$
- High DC Current Gain
: $h_{FE} = 750(\text{Min}) @ I_C = 3A$
- Low Saturation Voltage
- Complement to Type BD650

APPLICATIONS

- Designed for use as complementary AF push-pull output stage applications

ABSOLUTE MAXIMUM RATINGS($T_a=25^\circ\text{C}$)

SYMBOL	PARAMETER	VALUE	UNIT
V_{CBO}	Collector-Base Voltage	120	V
V_{CEO}	Collector-Emitter Voltage	100	V
V_{EBO}	Emitter-Base Voltage	5	V
I_C	Collector Current-Continuous	8	A
I_{CP}	Collector Current-Peak	12	A
I_B	Base Current-Continuous	0.3	A
P_C	Collector Power Dissipation @ $T_a=25^\circ\text{C}$	2	W
	Collector Power Dissipation @ $T_c=25^\circ\text{C}$	62.5	
T_J	Junction Temperature	150	$^\circ\text{C}$
T_{stg}	Storage Temperature Range	-65~150	$^\circ\text{C}$

THERMAL CHARACTERISTICS

SYMBOL	PARAMETER	MAX	UNIT
$R_{th\ j-c}$	Thermal Resistance, Junction to Case	2	$^\circ\text{C/W}$
$R_{th\ j-a}$	Thermal Resistance, Junction to Ambient	62.5	$^\circ\text{C/W}$

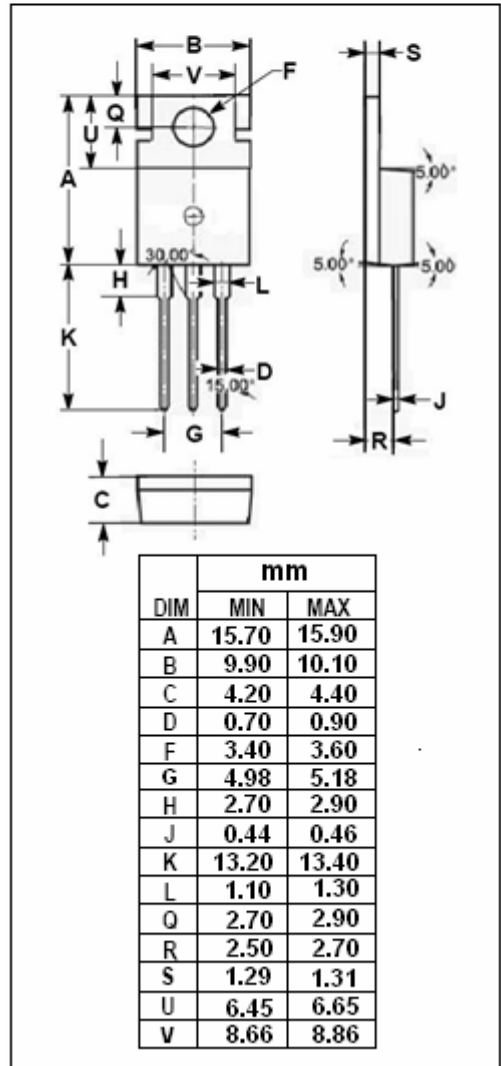
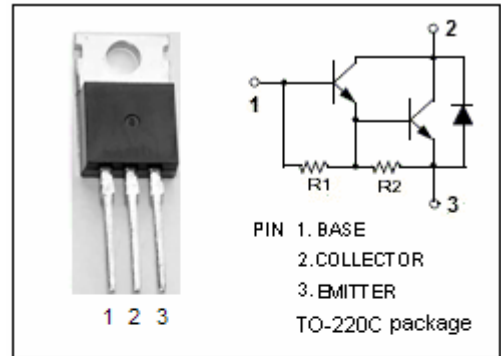

isc Silicon NPN Darlington Power Transistor**BD649****ELECTRICAL CHARACTERISTICS** $T_C=25^\circ\text{C}$ unless otherwise specified

SYMBOL	PARAMETER	CONDITIONS	MIN	TYP.	MAX	UNIT
$V_{CEO(SUS)}$	Collector-Emitter Breakdown Voltage	$I_C=30\text{mA}; I_B=0$	100			V
$V_{CE(sat)-1}$	Collector-Emitter Saturation Voltage	$I_C=3\text{A}; I_B=12\text{mA}$			2.0	V
$V_{CE(sat)-2}$	Collector-Emitter Saturation Voltage	$I_C=5\text{A}; I_B=50\text{mA}$			2.5	V
$V_{BE(sat)}$	Base-Emitter Saturation Voltage	$I_C=5\text{A}; I_B=50\text{mA}$			3.0	V
$V_{BE(on)}$	Base-Emitter On Voltage	$I_C=3\text{A}; V_{CE}=3\text{V}$			2.5	V
I_{CBO}	Collector Cutoff Current	$V_{CB}=100\text{V}; I_E=0$			0.2	mA
		$V_{CB}=60\text{V}; I_E=0; T_C=150^\circ\text{C}$			2.0	
I_{CEO}	Collector Cutoff Current	$V_{CE}=50\text{V}; I_B=0$			0.5	mA
I_{EBO}	Emitter Cutoff Current	$V_{EB}=5\text{V}; I_C=0$			5	mA
h_{FE}	DC Current Gain	$I_C=3\text{A}; V_{CE}=3\text{V}$	750			