

■ General Description

The AME8816 family of positive, linear regulators feature low quiescent current (45 μ A typ.) with low dropout voltage, making them ideal for battery applications.

Output voltages are set at the factory and trimmed to 1.5% accuracy.

These rugged devices have both Thermal Shutdown, and Current Fold-back to prevent device failure under the "Worst" of operating conditions.

In applications requiring a low noise, regulated supply, place a 1000pF capacitor between Bypass and Ground.

The AME8816 is stable with an output capacitance of 4.7 μ F or greater.

■ Features

- Very Low Dropout Voltage
- Guaranteed 1.5A Output
- Accurate to within 1.5%
- 45 μ A Quiescent Current Typically
- Over-Temperature Shutdown
- Current Limiting
- Short Circuit Current Fold-back
- Noise Reduction Bypass Capacitor (Fixed Versions)
- Power-Saving Shutdown Mode
- Space-Saving DDPAK-5 Package
- 6 Factory Pre-set Output Voltages
- Low Temperature Coefficient
- Adjustable Version

■ Applications

- Instrumentation
- Portable Electronics
- Wireless Devices
- PC Peripherals
- Battery Powered Widgets

■ Functional Block Diagram (Fixed Versions)

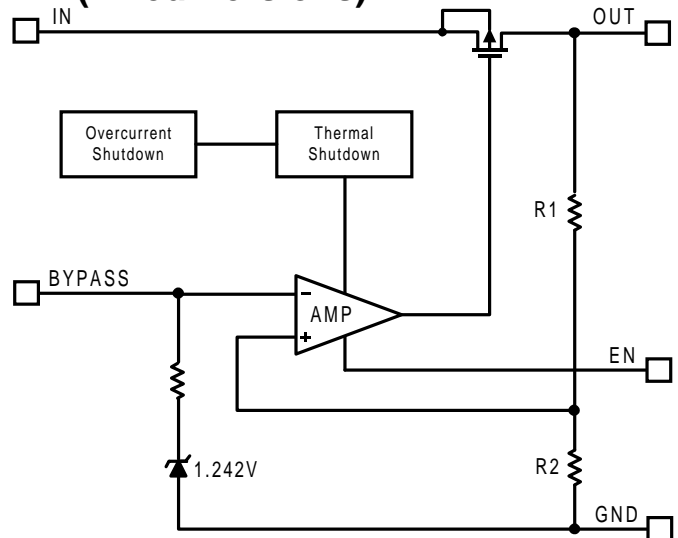

■ Functional Block Diagram (Adjustable Version)

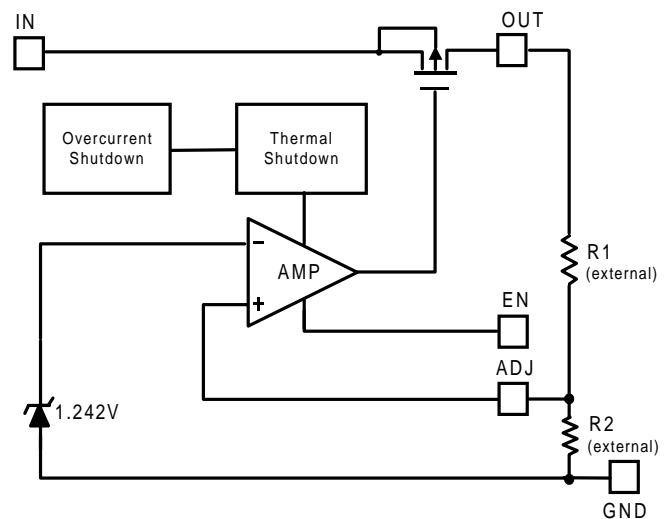

■ Typical Application

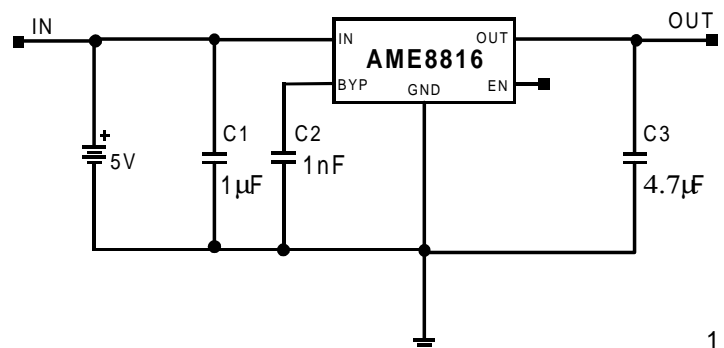



■ Pin Configuration

TO-263(DDPAK-5) Top View

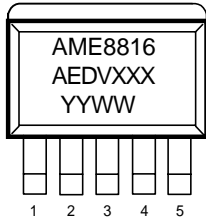

1. EN
2. V_{IN}
3. GND
4. V_{OUT}
5. BYP

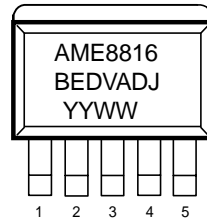

1. EN
2. V_{IN}
3. GND
4. V_{OUT}
5. ADJ

SO-8 Top View

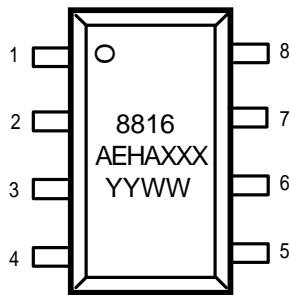

1. BYP
2. GND
3. GND
4. EN
5. V_{IN}
6. GND
7. GND
8. V_{OUT}

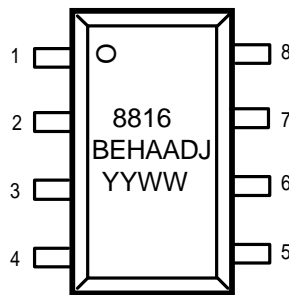

1. ADJ
2. GND
3. GND
4. EN
5. V_{IN}
6. GND
7. GND
8. V_{OUT}

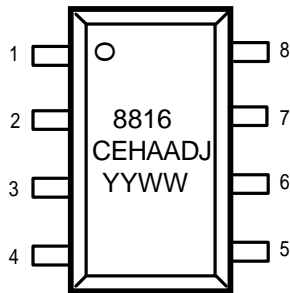

1. EN
2. V_{IN}
3. V_{OUT}
4. ADJ
5. GND
6. GND
7. GND
8. GND



■ **AME8816 Ordering Information**

V _{OUT}	Package Type	
	DDPAK-5	SO-8
1.50	AME8816AEDV150	AME8816AEHA150
1.80	AME8816AEDV180	AME8816AEHA180
2.50	AME8816AEDV250	AME8816AEHA250
3.30	AME8816AEDV330	AME8816AEHA330
4.75	AME8816AEDV475	AME8816AEHA475
5.00	AME8816AEDV500	AME8816AEHA500
ADJ	AME8816BEDVADJ	AME8816BEHAADJ
ADJ		AME8816CEHAADJ

Please consult AME sales office or authorized Rep./Distr. For other output voltage and package type or pinout availability.



■ Absolute Maximum Ratings:

Parameter	Maximum	Unit
Input Voltage	8	V
Output Current	$P_D / (V_{IN} - V_O)$	mA
Output Voltage	GND - 0.3 to $V_{IN} + 0.3$	V
ESD Classification	B	

Caution: Stress above the listed absolute maximum rating may cause permanent damage to the device.

■ Recommended operating Conditions:

Parameter	Rating	Unit
Ambient Temperature Range	-40 to +85	°C
Junction Temperature	-40 to +125	°C

■ Thermal Information

Parameter	Maximum	Unit
Thermal Resistance (θ_{jc})	TO-263 (DDPAK-5)	5
	SO-8	20**
Internal Power Dissipation (P_D) ($\Delta T = 100^\circ\text{C}$)*	TO-263 (DDPAK-5)	3.00
	SO-8	2.50
Maximum Junction Temperature	150	°C
Maximum Lead Temperature (10 Sec)	300	°C

* Assuming a heat sink capable of twice times (θ_{jc})

** Estimated

■ Electrical Specifications

$V_{IN} = V_{O(nom)} + 2V$, $V_{EN} = V_{IN}$, $T_A = 25^\circ C$ unless otherwise noted

Parameter	Symbol	Test Condition	Min	Typ	Max	Units	
Input Voltage	V_{IN}		Note 1		7	V	
Output Voltage Accuracy	V_O	$V_{EN} = V_{EHmin}$, $I_O = 1mA$	-1.5		1.5	%	
Dropout Voltage	$V_{DROPOUT}$	$I_O = 1.5A$ $V_O = V_{ONOM} - 2.0\%$	$1.5V < V_{O(NOM)} \leq 2.0V$	See chart	1300	mV	
			$2.0V < V_{O(NOM)} \leq 2.8V$		800		
			$2.8V < V_{O(NOM)}$		600		
Output Current	I_O	$V_O > 1.2V$	1500			mA	
Current Limit	I_{LIM}	$V_O > 1.2V$	1500	2000		mA	
Short Circuit Current	I_{SC}	$V_O < 0.4V$		750		mA	
Quiescent Current	I_Q	$I_O = 0mA$		45	70	μA	
Minimum Load Current (For ADJ Option)	I_{MIN}		1			mA	
Ground Pin Current	I_{GND}	$I_O = 1mA$ to 1.5A		45		μA	
Line Regulation	REG_{LINE}	$I_O = 1mA$ $V_{IN} = V_O + 1$ to $V_O + 2$	$V_O < 2.0V$	-0.15	0.15	%	
			$4.0 > V_O \geq 2.0V$	-0.1	0.02	0.1	%
			$4.0V \leq V_O$	-0.4		0.4	%
Load Regulation	REG_{LOAD}	$I_O = 1mA$ to 1.5A	-1	0.2	1	%	
Over Temperature Shutdown	OTS			150		$^\circ C$	
Over Temperature Hysteresis	OTH			30		$^\circ C$	
V_O Temperature Coefficient	TC			30		ppm/ $^\circ C$	
ADJ Input Bias Current	I_{ADJ}	$V_{IN} = 5V$, $V_{ADJ} = 1.242V$		1		μA	
ADJ Reference Voltage	V_{REF}		1.223	1.242	1.261	V	
Power Supply Rejection	PSRR	$I_O = 100mA$ $C_O = 4.7\mu F$ ceramic	$f = 1kHz$		50	dB	
			$f = 10kHz$		20		
			$f = 100kHz$		15		
Power Supply Rejection	PSRR	$I_O = 100mA$ $C_O = 4.7\mu F$ ceramic $C_{BYP} = 0.01\mu F$	$f = 1kHz$		75	dB	
			$f = 10kHz$		55		
			$f = 100kHz$		30		
Output Voltage Noise	eN	$f = 10Hz$ to 100kHz $I_O = 10mA$, $C_{BYP} = 0\mu F$			30	μV_{rms}	
Output Voltage Noise	eN	$f = 10Hz$ to 100kHz $I_O = 10mA$, $C_{BYP} = 0.01\mu F$			30	μV_{rms}	
EN Input Threshold	V_{EH}		2.0		V_{in}	V	
	V_{EL}		0		0.4	V	
EN Input Bias Current	I_{EH}	$V_{IN} = 7V$			0.1	μA	
	I_{EL}	$V_{EN} = 0V$, $V_{IN} = 7V$			0.5	μA	
Shutdown Supply Current	I_{SD}	$V_{IN} = 5V$, $V_O = 0V$, $V_{EN} = 0V$		0.5	2	μA	

Note1. $V_{IN(min)} = V_{OUT} + V_{DROPOUT}$

Note2. $V_{O(nom)}$: nominal output voltage of fixed version



■ Detailed Description

The AME8816 family of CMOS regulators contain a PMOS pass transistor, voltage reference, error amplifier, over-current protection, and thermal shutdown.

The P-channel pass transistor receives data from the error amplifier, over-current shutdown, and thermal protection circuits. During normal operation, the error amplifier compares the output voltage to a precision reference. Over-current and Thermal shutdown circuits become active when the junction temperature exceeds 140°C, or the current exceeds 2.2A. During thermal shutdown, the output voltage remains low. Normal operation is restored when the junction temperature drops below 120°C.

The AME8816 behaves like a current source when the load reaches 2.2A. However, if the load impedance drops below 0.3 ohms, the current drops back to 600mA to prevent excessive power dissipation. Normal operation is restored when the load resistance exceeds 0.75 ohms.

■ External Capacitors

The AME8816 is stable with an output capacitor to ground of 4.7µF or greater. Ceramic capacitors have the lowest ESR, and will offer the best AC performance. Conversely, Aluminum Electrolytic capacitors exhibit the highest ESR, resulting in the poorest AC response. Unfortunately, large value ceramic capacitors are comparatively expensive. One option is to parallel a 0.1µF ceramic capacitor with a 10µF Aluminum Electrolytic. The benefit is low ESR, high capacitance, and low overall cost.

A second capacitor is recommended between the input and ground to stabilize Vin. The input capacitor should be at least 0.1µF to have a beneficial effect.

A third capacitor can be connected between the BY-PASS pin and GND. This capacitor can be a low cost Polyester Film variety between the value of 0.001 ~ 0.01µF. A larger capacitor improves the AC ripple rejection, but also makes the output come up slowly. This "Soft" turn-on is desirable in some applications to limit turn-on surges.

All capacitors should be placed in close proximity to the pins. A "Quiet" ground termination is desirable. This can be achieved with a "Star" connection.

■ Enable

When pulled low, the PMOS pass transistor shuts off, and all internal circuits are powered down. In this state, the quiescent current is less than 1µA. This pin behaves much like an electronic switch.

100Kohm resistor is necessary between V_{EN} source and EN pin when V_{EN} is higher than V_{IN}.

Note: There is no internal pull-up for EN PIN.

■ Adjustable Version

The adjustable version uses external feedback resistors to generate an output voltage anywhere from 1.5V to 5.0V. V_{adj} is trimmed to 1.242V and V_{OUT} is given by the equation:

$$V_{OUT} = V_{adj} (1 + R1 / R2)$$

Feedback resistors R1 and R2 should be high enough to keep quiescent current low, but increasing R1 + R2 will reduce stability. In general, R1 and R2 in the 10's of kΩ will produce adequate stability, given reasonable layout precautions. To improve stability characteristics, keep

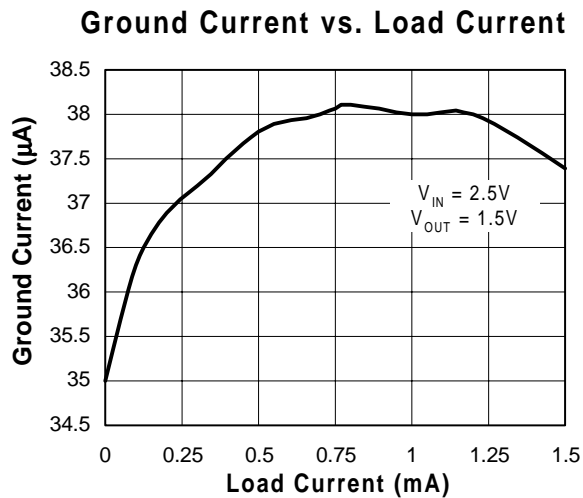
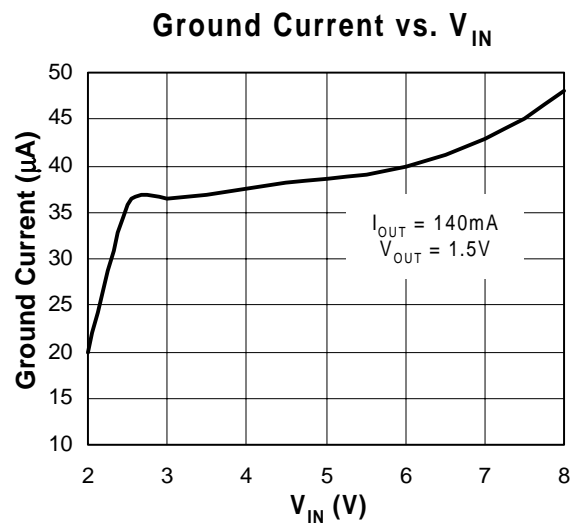
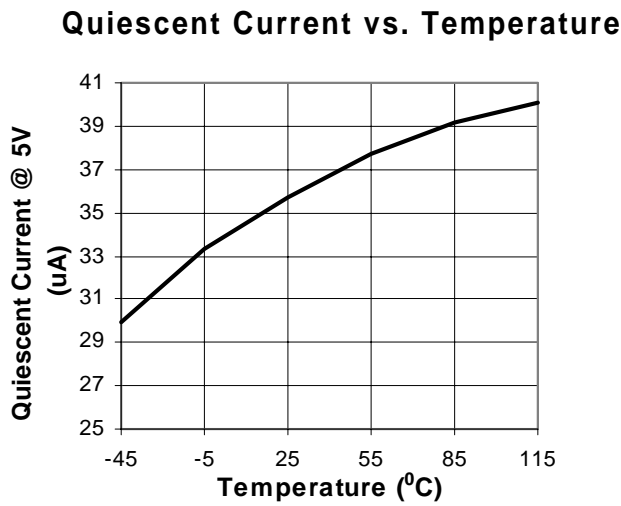
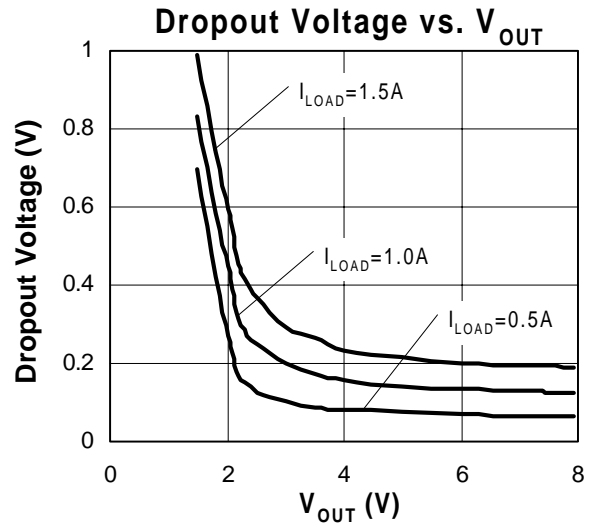
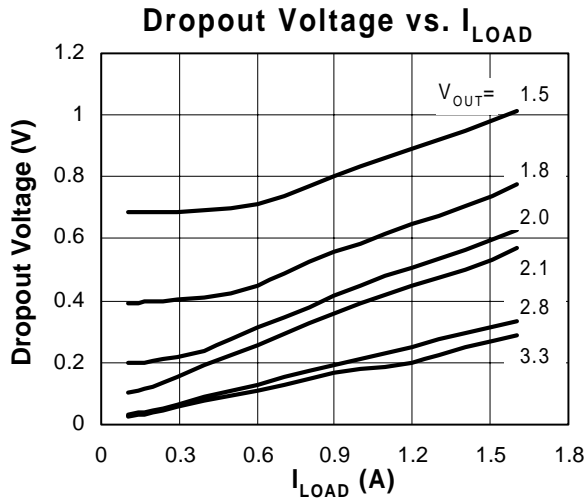



V_{OUT} vs. Temperature (2.5V)

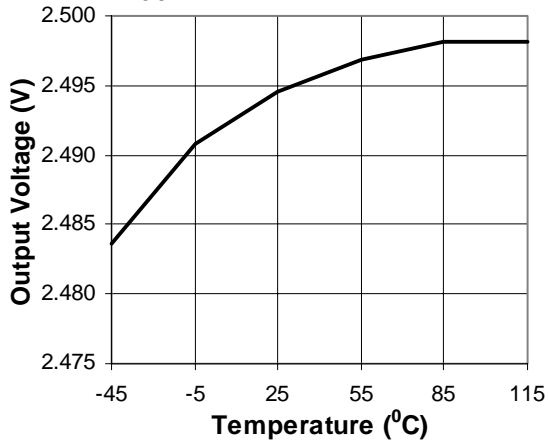

Load Regulation vs. Temperature

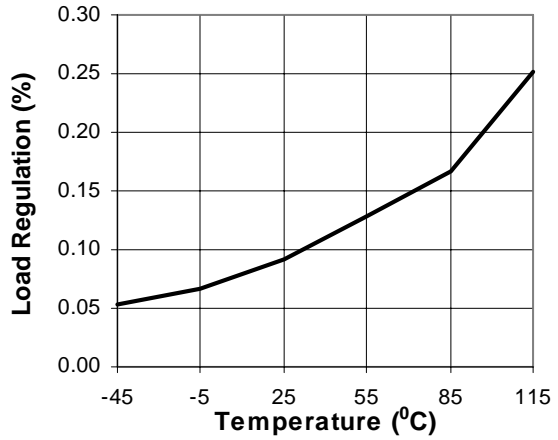

Dropout Voltage vs. Load Current (2.5V)

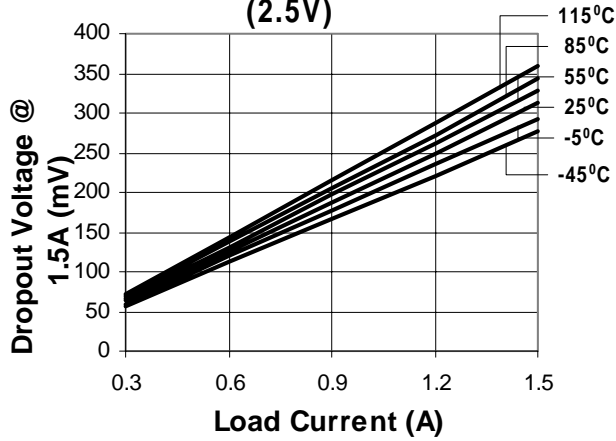

AME8816BEHA VADJ vs Temperature

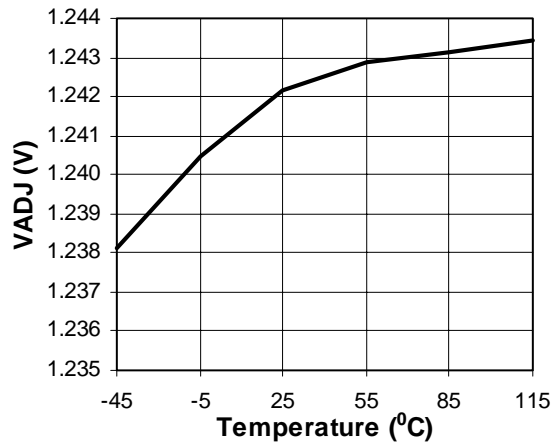

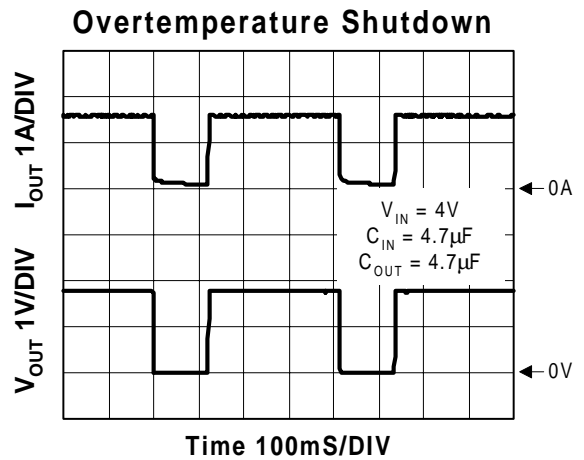
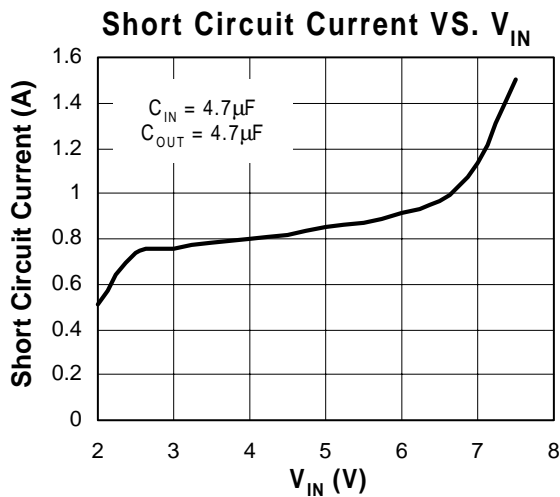
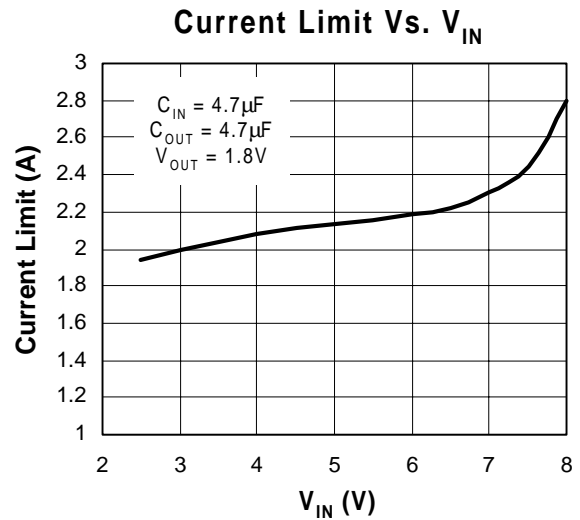
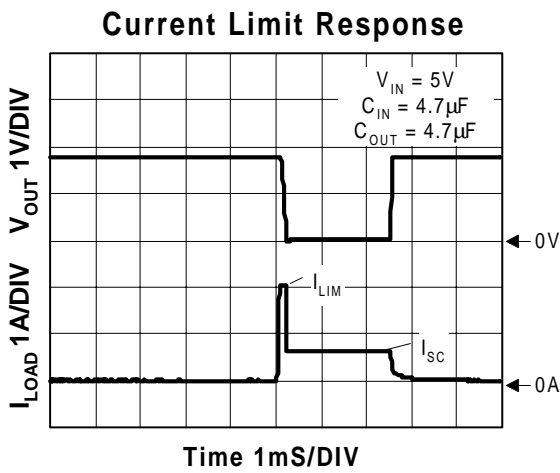
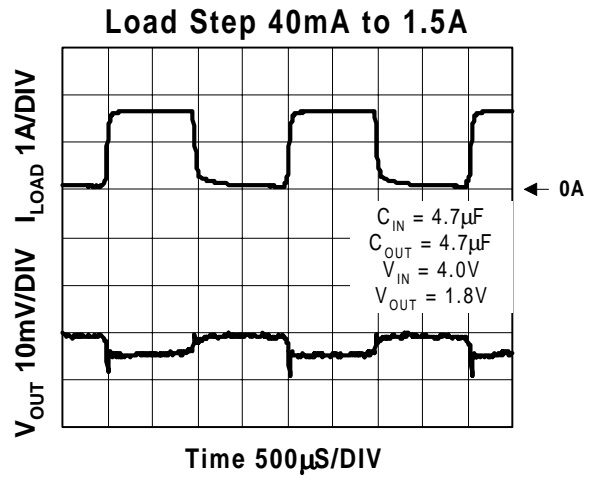
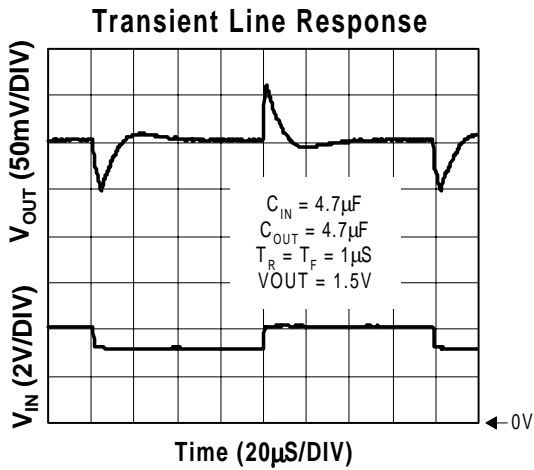

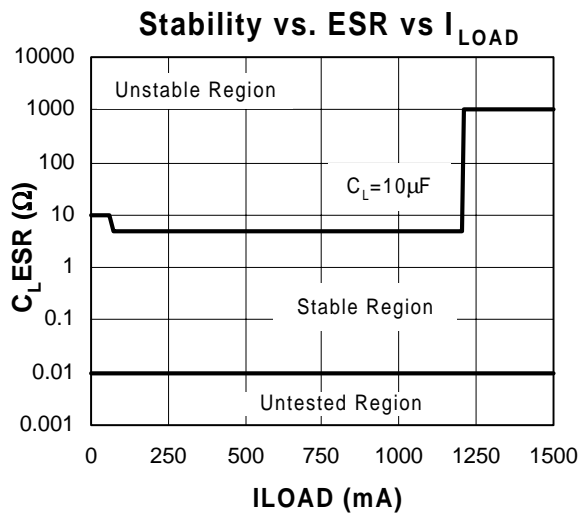
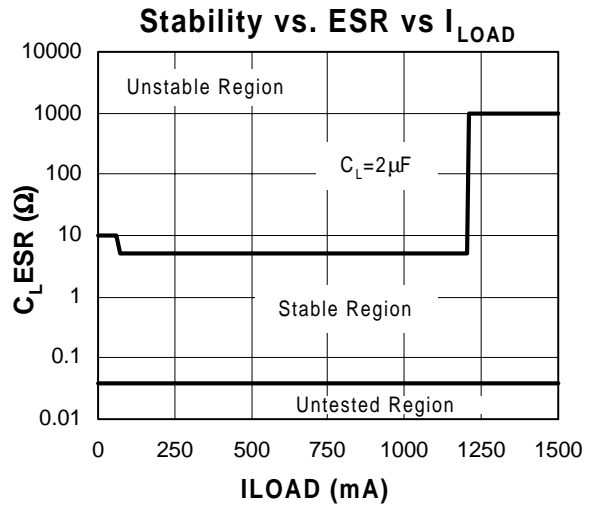
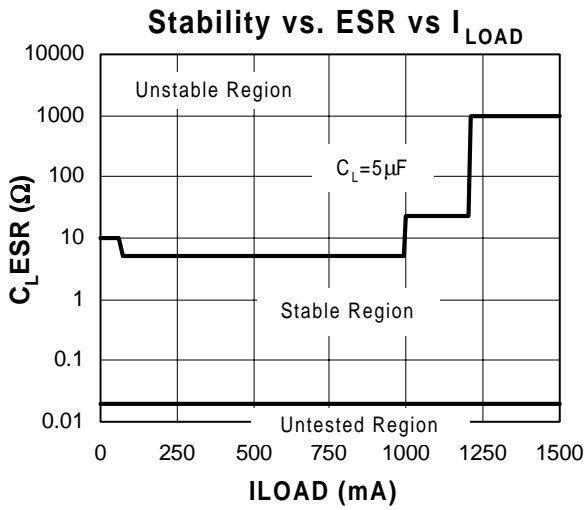

External Resistor Divider Table

R1(kohm)	1.00	2.00	5.00	10.00	20.00	50.00	100.00	200.00	500.00	1000.00
Vout	$R2(\text{kohm})=(1.242 \cdot R1(\text{kohm})) / (V_{\text{out}} - 1.242)$									
1.30	21.41	42.83	107.07	214.14	428.28	1070.69				
1.35	11.50	23.00	57.50	115.00	230.00	575.00				
1.40	7.86	15.72	39.30	78.61	157.22	393.04				
1.45	5.97	11.94	29.86	59.71	119.42	298.56	597.55			
1.50	4.81	9.63	24.07	48.14	96.28	240.70	481.68	962.79		
1.55	4.03	8.06	20.16	40.32	80.65	201.62	403.44	806.49		
1.60	3.47	6.94	17.35	34.69	69.39	173.46	347.07	693.85		
1.65	3.04	6.09	15.22	30.44	60.88	152.21	304.52	608.82		
1.70	2.71	5.42	13.56	27.12	54.24	135.59	271.27	542.36		
1.75	2.44	4.89	12.22	24.45	48.90	122.24	244.56	488.98		
1.80	2.23	4.45	11.13	22.26	44.52	111.29	222.64	445.16		
1.85	2.04	4.09	10.21	20.43	40.86	102.14	204.33	408.55		
1.90	1.89	3.78	9.44	18.88	37.75	94.38	188.80	377.51		
1.95	1.75	3.51	8.77	17.54	35.08	87.71	175.46	350.85	877.12	
2.00	1.64	3.28	8.19	16.39	32.77	81.93	163.88	327.70	819.26	
2.05	1.54	3.07	7.69	15.37	30.74	76.86	153.74	307.43	768.56	
2.10	1.45	2.90	7.24	14.48	28.95	72.38	144.78	289.51	723.78	
2.15	1.37	2.74	6.84	13.68	27.36	68.39	136.81	273.57	683.92	
2.20	1.30	2.59	6.48	12.96	25.93	64.82	129.67	259.29	648.23	
2.25	1.23	2.46	6.16	12.32	24.64	61.61	123.23	246.43	616.07	
2.30	1.17	2.35	5.87	11.74	23.48	58.70	117.41	234.78	586.96	
2.35	1.12	2.24	5.60	11.21	22.42	56.05	112.11	224.19	560.47	
2.40	1.07	2.15	5.36	10.73	21.45	53.63	107.27	214.51	536.27	
2.45	1.03	2.06	5.14	10.28	20.56	51.41	102.83	205.63	514.07	
2.50	0.99	1.97	4.94	9.87	19.75	49.36	98.74	197.46	493.64	
2.55	0.95	1.90	4.75	9.50	18.99	47.48	94.97	189.91	474.77	
2.60	0.91	1.83	4.57	9.15	18.29	45.73	91.47	182.92	457.29	914.58
2.65	0.88	1.76	4.41	8.82	17.64	44.11	88.22	176.42	441.05	882.10
2.70	0.85	1.70	4.26	8.52	17.04	42.59	85.19	170.37	425.93	851.85
2.75	0.82	1.65	4.12	8.24	16.47	41.18	82.37	164.72	411.80	823.61
2.80	0.80	1.59	3.99	7.97	15.94	39.86	79.73	159.44	398.59	797.18
2.85	0.77	1.54	3.86	7.72	15.45	38.62	77.25	154.48	386.19	772.39
2.90	0.75	1.50	3.75	7.49	14.98	37.45	74.92	149.82	374.55	749.10
2.95	0.73	1.45	3.64	7.27	14.54	36.36	72.72	145.43	363.58	727.17
3.00	0.71	1.41	3.53	7.06	14.13	35.32	70.65	141.30	353.24	706.48
3.05	0.69	1.37	3.43	6.87	13.74	34.35	68.70	137.39	343.47	686.95
3.10	0.67	1.34	3.34	6.68	13.37	33.42	66.85	133.69	334.23	668.46



External Resistor Divider Table (contd.)

R1(kohm)	1.00	2.00	5.00	10.00	20.00	50.00	100.00	200.00	500.00	1000.00
Vout	$R2(kohm)=(1.242*R1(kohm))/(V_{out}-1.242)$									
3.15	0.65	1.30	3.25	6.51	13.02	32.55	65.09	130.19	325.47	650.94
3.20	0.63	1.27	3.17	6.34	12.69	31.72	63.43	126.86	317.16	634.32
3.25	0.62	1.24	3.09	6.19	12.37	30.93	61.85	123.71	309.26	618.53
3.30	0.60	1.21	3.02	6.03	12.07	30.17	60.35	120.70	301.75	603.50
3.35	0.59	1.18	2.95	5.89	11.78	29.46	58.92	117.84	294.59	589.18
3.40	0.58	1.15	2.88	5.76	11.51	28.78	57.55	115.11	287.77	575.53
3.45	0.56	1.13	2.81	5.63	11.25	28.13	56.25	112.50	281.25	562.50
3.50	0.55	1.10	2.75	5.50	11.00	27.50	55.00	110.01	275.02	550.04
3.55	0.54	1.08	2.69	5.38	10.76	26.91	53.81	107.63	269.06	538.13
3.60	0.53	1.05	2.63	5.27	10.53	26.34	52.67	105.34	263.36	526.72
3.65	0.52	1.03	2.58	5.16	10.32	25.79	51.58	103.16	257.89	515.78
3.70	0.51	1.01	2.53	5.05	10.11	25.26	50.53	101.06	252.64	505.29
3.75	0.50	0.99	2.48	4.95	9.90	24.76	49.52	99.04	247.61	495.22
3.80	0.49	0.97	2.43	4.86	9.71	24.28	48.55	97.11	242.77	485.54
3.85	0.48	0.95	2.38	4.76	9.52	23.81	47.62	95.25	238.11	476.23
3.90	0.47	0.93	2.34	4.67	9.35	23.36	46.73	93.45	233.63	467.27
3.95	0.46	0.92	2.29	4.59	9.17	22.93	45.86	91.73	229.32	458.64
4.00	0.45	0.90	2.25	4.50	9.01	22.52	45.03	90.07	225.16	450.33
4.05	0.44	0.88	2.21	4.42	8.85	22.12	44.23	88.46	221.15	442.31
4.10	0.43	0.87	2.17	4.35	8.69	21.73	43.46	86.91	217.28	434.57
4.15	0.43	0.85	2.14	4.27	8.54	21.35	42.71	85.42	213.55	427.10
4.20	0.42	0.84	2.10	4.20	8.40	20.99	41.99	83.98	209.94	419.88
4.25	0.41	0.83	2.06	4.13	8.26	20.64	41.29	82.58	206.45	412.90
4.30	0.41	0.81	2.03	4.06	8.12	20.31	40.61	81.23	203.07	406.15
4.35	0.40	0.80	2.00	4.00	7.99	19.98	39.96	79.92	199.81	399.61
4.40	0.39	0.79	1.97	3.93	7.87	19.66	39.33	78.66	196.64	393.29
4.45	0.39	0.77	1.94	3.87	7.74	19.36	38.72	77.43	193.58	387.16
4.50	0.38	0.76	1.91	3.81	7.62	19.06	38.12	76.24	190.61	381.22
4.55	0.38	0.75	1.88	3.75	7.51	18.77	37.55	75.09	187.73	375.45
4.60	0.37	0.74	1.85	3.70	7.40	18.49	36.99	73.97	184.93	369.86
4.65	0.36	0.73	1.82	3.64	7.29	18.22	36.44	72.89	182.22	364.44
4.70	0.36	0.72	1.80	3.59	7.18	17.96	35.92	71.83	179.58	359.17
4.75	0.35	0.71	1.77	3.54	7.08	17.70	35.40	70.81	177.02	354.05
4.80	0.35	0.70	1.75	3.49	6.98	17.45	34.91	69.81	174.54	349.07
4.85	0.34	0.69	1.72	3.44	6.88	17.21	34.42	68.85	172.12	344.24
4.90	0.34	0.68	1.70	3.40	6.79	16.98	33.95	67.91	169.76	339.53
4.95	0.33	0.67	1.67	3.35	6.70	16.75	33.50	66.99	167.48	334.95
5.00	0.33	0.66	1.65	3.30	6.61	16.52	33.05	66.10	165.25	330.49

Note: Small load(greater than 2 mA) is necessary as R1 or R2 is larger than 50 Kohm. Otherwise, output voltage probably cannot be pulled down to 0 V on disable mode.

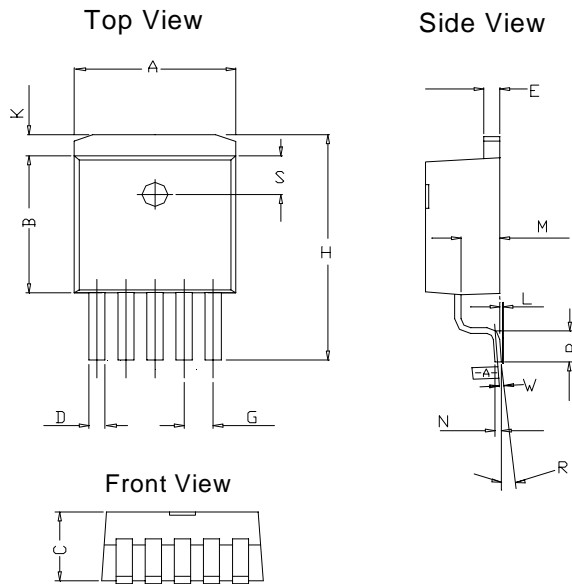
■ Package Dimension
TO-263 (DDPAK-5)

SYMBOLS	MILLIMETERS		INCHES	
	MIN	MAX	MIN	MAX
A	10.05	10.31	0.396	0.406
B	8.28	8.53	0.326	0.336
C	4.31	4.57	0.170	0.180
D	0.66	0.91	0.026	0.036
E	1.14	1.40	0.045	0.055
G	1.70 ref		0.067 ref	
H	14.73	15.75	0.580	0.620
K	1.40	1.68	0.000	0.066
L	0.00	0.25	0.055	0.010
M	2.49	2.74	0.000	0.108
N	0.43	0.58	0.098	0.023
P	2.29	2.79	0.017	0.110
R	0°	8°	0°	8°
S	2.41	2.67	0.095	0.105
W	0.25		0.01	

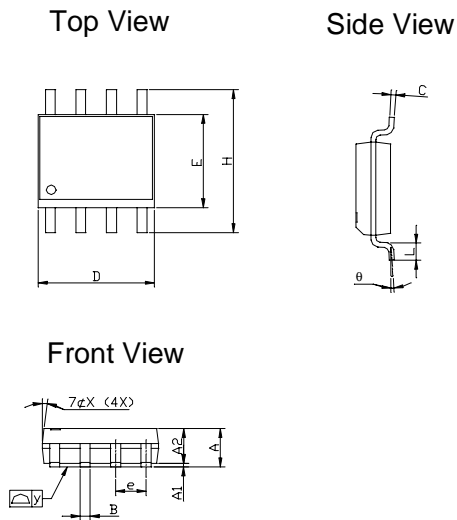
SO-8

SYMBOLS	MILLIMETERS		INCHES	
	MIN	MAX	MIN	MAX
A	1.35	1.75	0.053	0.069
A ₁	0.10	0.25	0.004	0.010
A ₂	1.45 REF		0.057 REF	
B	0.33	0.51	0.013	0.020
C	0.19	0.25	0.007	0.010
D	4.80	5.00	0.189	0.1970
E	3.80	4.00	0.150	0.157
e	1.27 BSC		0.050 BSC	
H	5.80	6.20	0.228	0.244
L	0.40	1.27	0.016	0.050
y	-	0.10	-	0.004
θ	0°	8°	0°	8°



www.ame.com.tw
E-Mail: info@ame.com.tw

Life Support Policy:

These products of AME, Inc. are not authorized for use as critical components in life-support devices or systems, without the express written approval of the president of AME, Inc.

AME, Inc. reserves the right to make changes in the circuitry and specifications of its devices and advises its customers to obtain the latest version of relevant information.

© AME, Inc. , January 2002
Document: 2013-DS8816-C

U.S. Headquarters
Analog Microelectronics, Inc.

3100 De La Cruz Blvd. Suite 201
Santa Clara, CA. 95054-2046
Tel : (408) 988-2388
Fax: (408) 988-2489

Corporate Headquarters
AME, Inc.

2F, 189 Kang-Chien Road, Nei-Hu Dist.
Taipei 114 Taiwan, R.O.C.
Tel : 886 2 2627-8687
Fax: 886 2 2659-2989