



Integrated Power Solution for TFT-LCD

Features

- 2.5V to 5.5V Input Supply Range
- 1.2MHz Current-Mode Step-Up Converter
- Built-In 18V, 3A 0.2Ω n-Channel MOSFET
- Charge Pumps for V_{GON} and V_{GOFF}
- High Voltage Switch with Adjustable Delay
- Thermal Overload Protection
- TQFN4X4-24 Package

Applications

- LCD Monitor Panels
- Notebook Computer Displays
- LCD TVs

General Description

The G5517 includes a step-up converter, two charge pumps, and a high current operational amplifier for TFT LCD. Also included are a logic-controlled high-voltage switch with adjustable delay and an open drain output reset comparator.

The step-up DC/DC converter provides the regulated power supply for the panel source driver IC. The converter is a high performance current-mode regulator with operating frequency at 1.2MHz. It also provides fast transient response and high efficiency.

The charge pumps in G5517 regulate TFT gate-on and gate-off power supplies. The power-on sequence is controlled by the control logic. The blanking time for reset function is 163ms (typ.) from startup. The RSTIN begins to detect voltage below 1.25V afterward. For more detail information, please refer to the timing chart.

G5517 is available in TQFN4X4-24 package

Ordering Information

ORDER NUMBER	MARKING	TEMP. RANGE	PACKAGE (Green)
G5517R51U	5517	-40°C to 85°C	TQFN4X4-24

Note: R5: TQFN4X4-24

1: Bonding Code

U: Tape & Reel

Pin Configuration

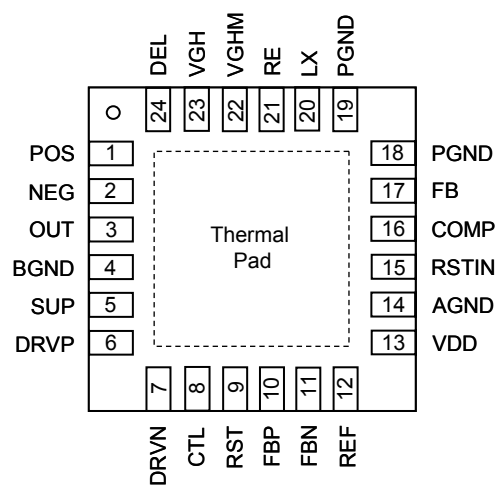

G5517 TQFN4X4-24

Note: Recommend connecting the Thermal Pad to the Ground for excellent power dissipation.