

LM1819 Air-Core Meter Driver

General Description

The LM1819 is a function generator/driver for air-core (moving-magnet) meter movements. A Norton amplifier and an NPN transistor are included on chip for signal conditioning as required. Driver outputs are self-centering and develop $\pm 4.5V$ swing at 20 mA. Better than 2% linearity is guaranteed over a full 305-degree operating range.

Features

- Self-centering 20 mA outputs
- 12V operation
- Norton amplifier
- Function generator

Applications

- Air-core meter driver
- Tachometers
- Ruggedized instruments

Typical Application

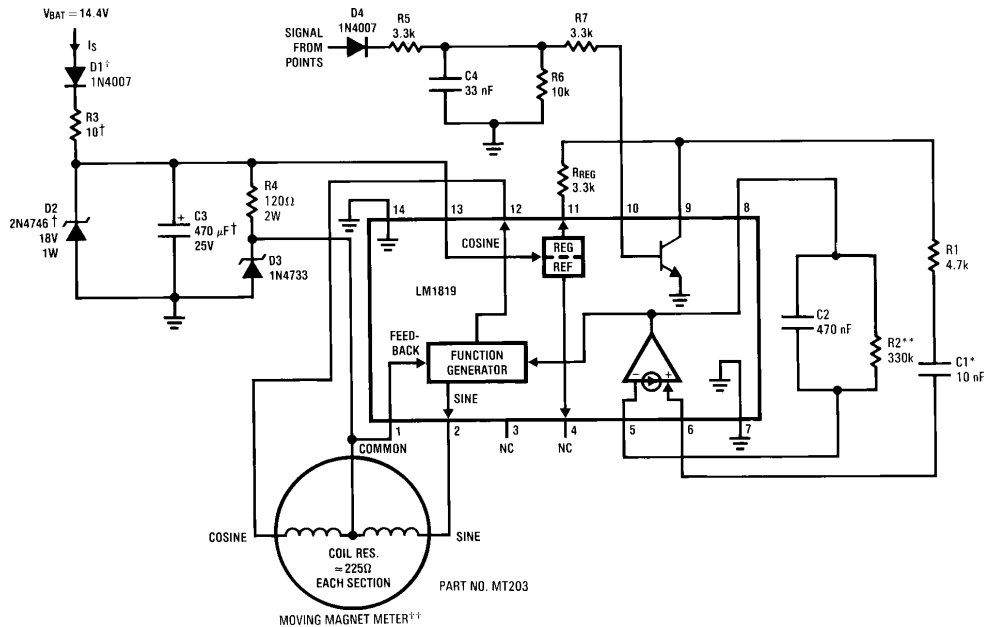

TL/H/5263-1

FIGURE 1. Automotive Tachometer Application. Circuit shown operates with 4 cylinder engine and deflects meter pointer (270°) at 6000 RPM.

**Order Number LM1819M or LM1819N
See NS Package Number M14A or N14A**

*TRW Type X463UW Polycarbonate Capacitor

**RN60D Low TC Resistor (± 100 ppm)

†Components Required for Automotive Load Dump Protection

††Available from FARIA Co.

P O Box 983, Uncasville, CT 06382
Tel. 203-848-9271

Absolute Maximum Ratings

If Military/Aerospace specified devices are required, please contact the National Semiconductor Sales Office/Distributors for availability and specifications.

Supply Voltage, V^+ (pin 13) 20V
Power Dissipation (note 1) 1300 mW

Operating Temperature -40°C to $+85^{\circ}\text{C}$
Storage Temperature -65°C to -150°C
Lead Temp. (Soldering, 10 seconds) 260°C
 BV_{CEO} 20V_{MIN}

Electrical Characteristics $V_S = 13.1\text{V}$ $T_A = 25^{\circ}\text{C}$ unless otherwise specified

Symbol	Parameter	Pin(s)	Conditions	Min	Typ	Max	Units
I_S	Supply Current	13	Zero Input Frequency (See Figure 1)			65	mA
V_{REG}	Regulator Voltage	11	$I_{REG} = 0\text{ mA}$	8.1	8.5	8.9	V
	Regulator Output Resistance	11	$I_{REG} = 0\text{ mA}$ to 3 mA		13.5		Ω
V_{REF}	Reference Voltage	4	$I_{REF} = 0\text{ mA}$	1.9	2.1	2.3	V
	Reference Output Resistance	4	$I_{REF} = 0\ \mu\text{A}$ to 50 μA		5.3		k Ω
	Norton Amplifier Mirror Gain	5, 6	$I_{BIAS} \approx 20\ \mu\text{A}$	0.9	1.0	1.1	
h_{FE}	NPN Transistor DC Gain	9, 10			125		
	Function Generator Feedback Bias Current	1	$V_1 = 5.1\text{V}$		1.0		mA
	Drive Voltage Extremes, Sine and Cosine	2, 12	$I_{LOAD} = 20\text{ mA}$	± 4	± 4.5		V
	Sine Output Voltage with Zero Input	2	$V_8 = V_{REF}$	-350	0	+350	mV
	Function Generator Linearity		FSD = 305°			± 1.7	%FSD
k	Function Generator Gain		Meter Deflection/ ΔV_8	50.75	53.75	56.75	$^{\circ}/\text{V}$

Note 1: For operation above 25°C, the LM1819 must be derated based upon a 125°C maximum junction temperature and a thermal resistance of 76°C/W which applies for the device soldered in a printed circuit board and operating in a still-air ambient.

Application Hints

AIR-CORE METER MOVEMENTS

Air-core meters are often favored over other movements as a result of their mechanical ruggedness and their independence of calibration with age. A simplified diagram of an air-core meter is shown in Figure 2. There are three basic pieces: a magnet and pointer attached to a freely rotating axle, and two coils, each oriented at a right angle with respect to the other. The only moving part in this meter is the axle assembly. The magnet will tend to align itself with the vector sum of H fields of each coil, where H is the magnetic field strength vector. If, for instance, a current passes through the cosine coil (the reason for this nomenclature will become apparent later) as shown in Figure 3(a), the magnet will align its magnetic axis with the coil's H field. Similarly, a current in the sine coil (Figure 3(b)) causes the magnet to align itself with the sine H field. If currents are applied simultaneously to both sine and cosine coils, the magnet will turn to the direction of the vector sum of the two

H fields (Figure 3(c)). H is proportional to the voltage applied to a coil. Therefore, by varying both the polarity and magnitude of the coil voltages the axle assembly can be made to rotate a full 360°. The LM1819 is designed to drive the meter through a minimum of 305°.

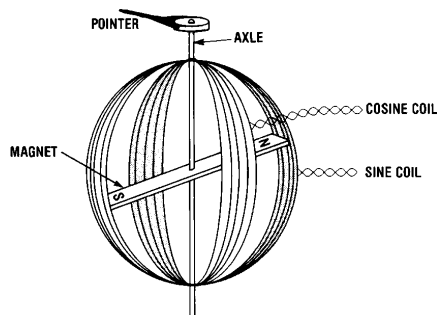

TL/H/5263-2
FIGURE 2. Simplified Diagram of an Air Core Meter.

Application Hints (Continued)

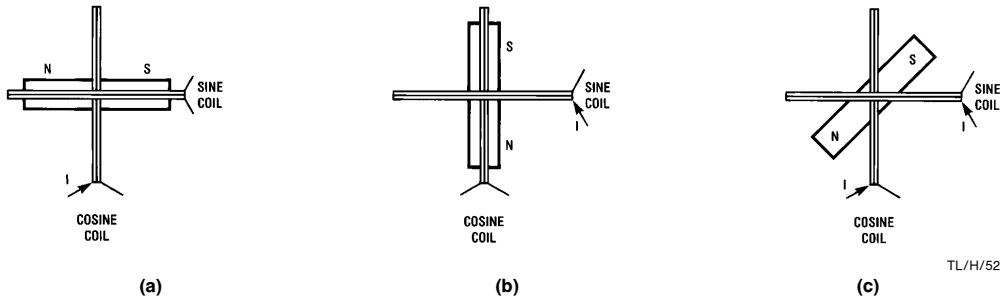

FIGURE 3. Magnet and pointer position are controlled by the H field generated by the two drive coils.

In an air-core meter the axle assembly is supported by two nylon bushings. The torque exerted on the pointer is much greater than that found in a typical d'Arsonval movement. In contrast to a d'Arsonval movement, where calibration is a function of spring and magnet characteristics, air-core meter calibration is only affected by the mechanical alignment of the drive coils. Mechanical calibration, once set at manufacture, can not change.

Making pointer position a linear function of some input is a matter of properly ratioing the drive to each coil. The H field contributed by each coil is a function of the applied current, and the current is a function of the coil voltage. Our desired result is to have θ (pointer deflection, measured in degrees) proportional to an input voltage:

$$\theta = kV_{IN} \quad [1]$$

where k is a constant of proportionality, with units of degrees/volt. The vector sum of each coils' H field must follow the deflection angle θ . We know that the axle assembly always points in the direction of the vector sum of H_{SINE} and H_{COSINE} . This direction (see Figure 4) is found from the formula:

$$(\theta) = \arctan \left\{ \frac{|H_{SINE}|}{|H_{COSINE}|} \right\} \quad [2]$$

Recalling some basic trigonometry,

$$(\theta) = \arctan(\sin(\theta) / \cos(\theta)) \quad [3]$$

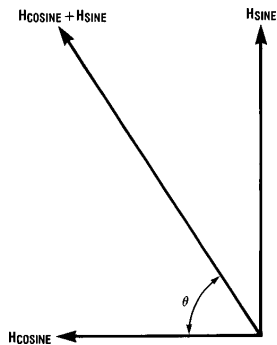

FIGURE 4. The vector sum of H_{COSINE} and H_{SINE} points in a direction θ measured in a clockwise direction from H_{COSINE} .

Comparing [3] to [2] we see that if H_{SINE} varies as the sine of θ , and H_{COSINE} varies as the cosine of θ , we will generate a net H field whose direction is the same as θ . And since the axle assembly aligns itself with the net H field, the pointer will always point in the direction of θ .

THE LM1819

Included in the LM1819 is a function generator whose two outputs are designed to vary approximately as the sine and cosine of an input. A minimum drive of ± 20 mA at ± 4 V is available at pins 2 (sine) and 12 (cosine). The common side of each coil is returned to a 5.1V zener diode reference and fed back to pin 1.

For the function generator, $k \approx 54^\circ/V$ (in equation 1). The input (pin 8) is internally connected to the Norton amplifier's output. V_{IN} as considered in equation [1] is actually the difference of the voltages at pins 8 (Norton output/function generator input) and 4. Typically the reference voltage at pin 4 is 2.1V. Therefore,

$$\theta = k(V_8 - V_{REF}) = 54(V_8 - 2.1) \quad [4]$$

As V_8 varies from 2.1V to 7.75V, the function generator will drive the meter through the chip's rated 305° range.

Air-core meters are mechanically zeroed during manufacture such that when only the cosine coil is driven, the pointer indicates zero degrees deflection. However, in some applications a slight trim or offset may be required. This is accomplished by sourcing or sinking a DC current of a few microamperes at pin 4.

A Norton amplifier is available for conditioning various input signals and driving the function generator. A Norton amplifier was chosen since it makes a simple frequency to voltage converter. While the non-inverting input (pin 6) bias is at one diode drop above ground, the inverting input (5) is at 2.1V, equal to the pin 4 reference. Mirror gain remains essentially flat to $I_{MIRROR} = 5$ mA. The Norton amplifier's output (8) is designed to source current into its load. To bypass the Norton amplifier simply ground the non-inverting input, tie the inverting input to the reference, and drive pin 8 (Norton output/function generator input) directly.

An NPN transistor is included on chip for buffering and squaring input signals. Its usefulness is exemplified in Figures 1 & 6 where an ignition pulse is converted to a rectangular waveform by an RC network and the transistor. The emitter is internally connected to ground. It is important not to allow the base to drop below $-5V_{DC}$, as damage may occur. The 2.1V reference previously described is derived from an 8.5V regulator at pin 11. Pin 11 is used as a stable supply for collector loads, and currents of up to 5 mA are easily accommodated.

Application Hints (Continued)

TACHOMETER APPLICATION

A measure of the operating level of any motor or engine is the rotational velocity of its output shaft. In the case of an automotive engine the crankshaft speed is measured using the units "revolutions per minute" (RPM). It is possible to indirectly measure the speed of the crankshaft by using the signal present on the engine's ignition coil. The fundamental frequency of this signal is a function of engine speed and the number of cylinders and is calculated (for a four-stroke engine) from the formula:

$$f = n\omega/120 \quad (\text{Hz}) \quad (5)$$

where n = number of cylinders, and ω = rotational velocity of the crankshaft in RPM. From this formula the maximum frequency normally expected (for an 8 cylinder engine turning 4500RPM) is 300 Hz. In certain specialized ignition systems (motorcycles and some automobiles) where the coil waveform is operated at twice this frequency ($f = \omega/60$). These systems are identified by the fact that multiple coils are used in lieu of a single coil and distributor. Also, the coils have two outputs instead of one.

A typical automotive tachometer application is shown in *Figure 1*. The coil waveform is filtered, squared and limited by the RC network and NPN transistor. The frequency of the pulse train at pin 9 is converted to a proportional voltage by the Norton amplifier's charge pump configuration. The ignition circuit shown in *Figure 5* is typical of automotive systems. The switching element "S" is opened and closed in synchronism with engine rotation. When "S" is closed, energy is stored in Lp. When opened, the current in Lp diverts from "S" into C. The high voltage produced in Ls when "S" is opened is responsible for the arcing at the spark plug. The coil voltage (see *Figure 6*) can be used as an input to the LM1819 tachometer circuit. This waveform is essentially constant *duty cycle*. D4 rectifies this waveform thereby preventing negative voltages from reaching the chip. C4 and R5 form a low pass filter which attenuates the high frequency ringing, and R7 limits the input current to about 2.5mA. R6 acts as a base bleed to shut the transistor OFF when "S" is closed. The collector is pulled up to the internal regulator by RREG. The output at pin 9 is a clean rectangular pulse.

Many ignition systems use magnetic, hall effect or optical sensors to trigger a solid state switching element at "S." These systems (see the LM1815) typically generate pulses of constant *width* and amplitude suitable for driving the charge pump directly.

The charge pump circuit in *Figure 7* can be operated in two modes: constant input pulse width (C1 acts as a coupling capacitor) and constant input duty cycle (C1 acts as a differentiating capacitor). The transfer functions for these two modes are quite diverse. However, deflection is always directly proportional to R2 and ripple is proportional to C2.

The following variables are used in the calculation of meter deflection:

symbol	description
n	number of cylinders
ω, ω_{IDLE}	engine speed at redline and idle, RPM
θ	pointer deflection at redline, degrees
δ	charge pump input pulse width, seconds
V_{IN}	peak to peak input voltages, volts
$\Delta\theta$	maximum desired ripple, degrees
k	function generator gain, degrees/volt
f, f_{IDLE}	input frequency at redline and idle, Hz

Where the NPN transistor and regulator are used to create a pulse $V_{IN} = 8.5V$. Acceptable ripple ranges from 3 to 10 degrees (a typical pointer is about 3 degrees wide) depending on meter damping and the input frequency.

The constant pulse width circuit is designed using the following equations:

$$(1) \quad 100 \mu A < \frac{V_{IN}}{R_1} < 3 \text{ mA}$$

$$(2) \quad C_1 \geq \frac{10\delta}{R_1}$$

$$(3) \quad R_2 = \frac{R_1\theta}{V_{IN}\delta k f} = \frac{120R_1\theta}{V_{IN}n\omega\delta k}$$

$$(4) \quad C_2 = \frac{R_2\Delta\theta f_{IDLE}}{R_2\Delta\theta n\omega_{IDLE}}$$

The constant duty cycle equations are as follows:

$$R_{REG} \geq 3 \text{ k}\Omega$$

$$R_1 \leq V_{IN} \times 10^4 - R_{REG}$$

$$C_1 \leq \delta / 10(R_{REG} + R_1)$$

$$R_Z = \theta / 3.54n\omega C_1 = \theta / 425 / C_1$$

$$C_2 = 425C_1 / \Delta\theta$$

The values in *Figure 1* were calculated with $n=4$, $\omega=6000\text{RPM}$, $\theta=270$ degrees, $\delta=1$ ms, V_{IN} is $V_{REG}-0.7V$, and $\Delta\theta=3$ degrees in the constant duty cycle mode. For distributorless ignitions these same equations will apply if $\omega/60$ is substituted for f .

Equivalent Schematic

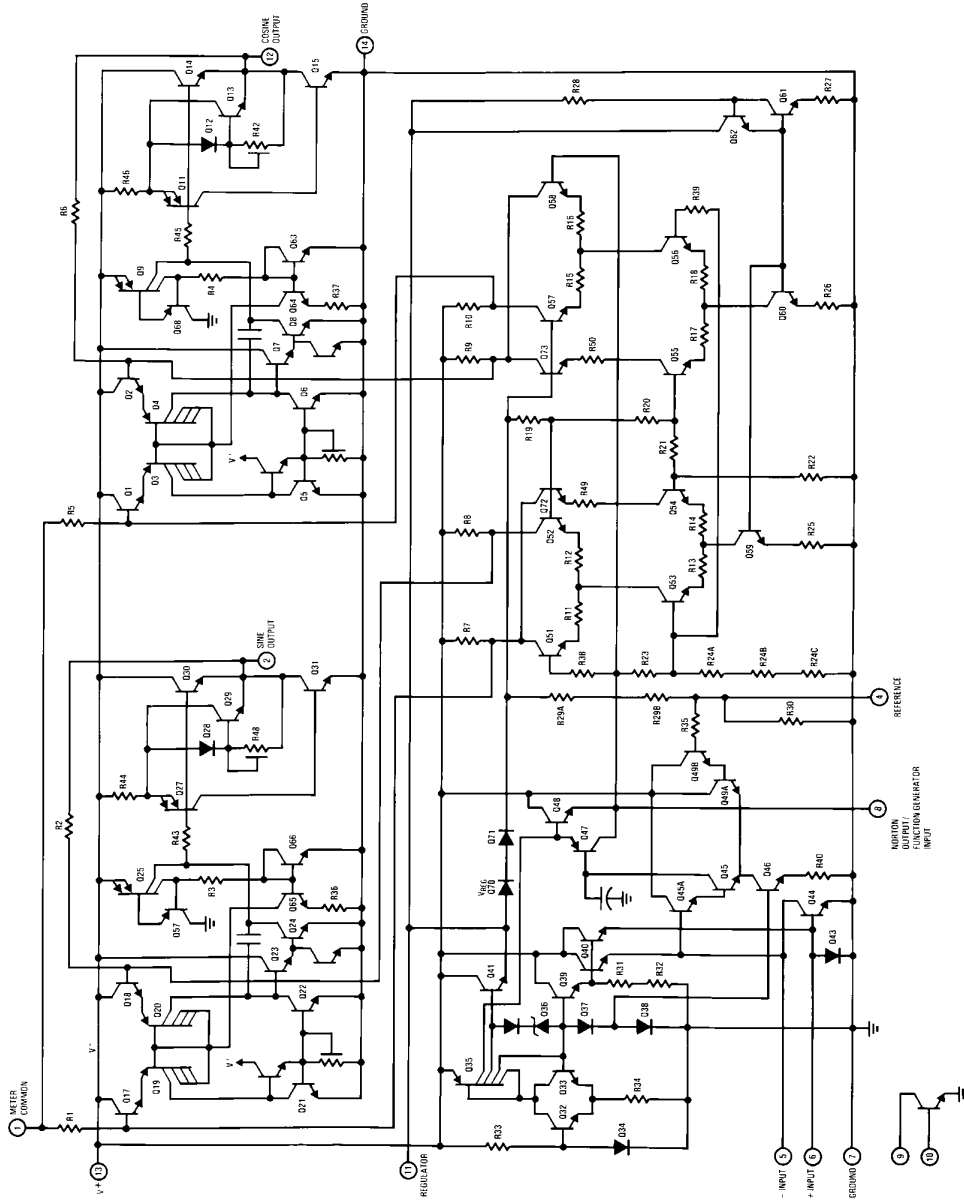

TL/H/5203-12

Typical Applications

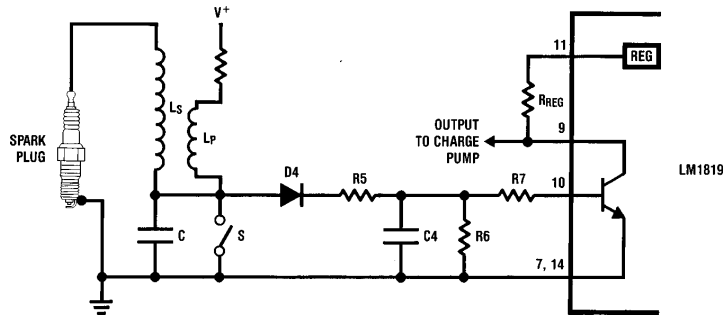

FIGURE 5. Typical Pulse-Squaring Circuit for Automotive Tachometers.

TL/H/5263-9

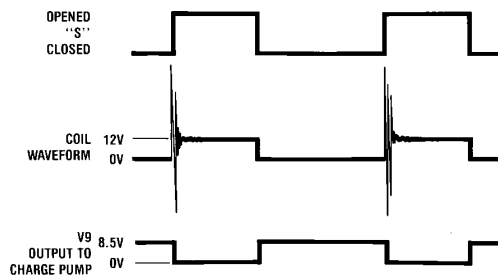
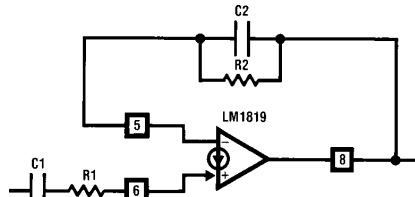

FIGURE 6. Waveforms Encountered in Automotive Tachometer Circuit.

TL/H/5263-10



TL/H/5263-11

FIGURE 7. Tachometer Charge Pump.

Voltage Driven Meter with Norton Amplifier Buffer

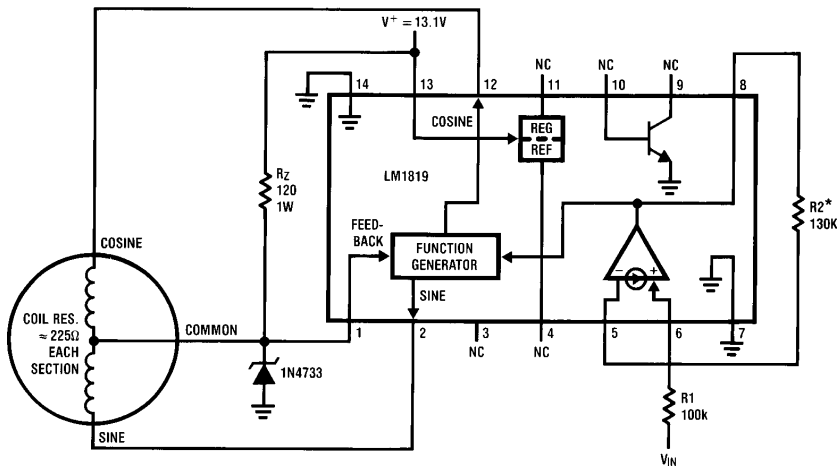

TL/H/5263-5

Deflection = $54 (V_{IN} - .7) R_2 / R_1$ (degrees)
 0 to 305° deflection is obtained with .7 to 5V input.
 *Full scale deflection is adjusted by trimming R_2 .

Typical Applications (Continued)

Unbuffered Voltage Driven Meter

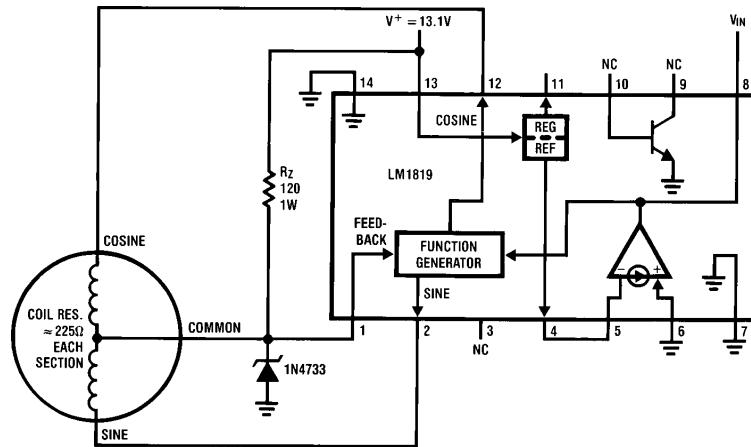

TL/H/5263-6

Deflection = $54(V_{IN} - 2.1)$ (degrees)
 0 to 305° deflection is obtained for inputs of 2.1 to 7.75V.
 Full scale deflection is adjusted by trimming the input voltage.

Current Driven Meter

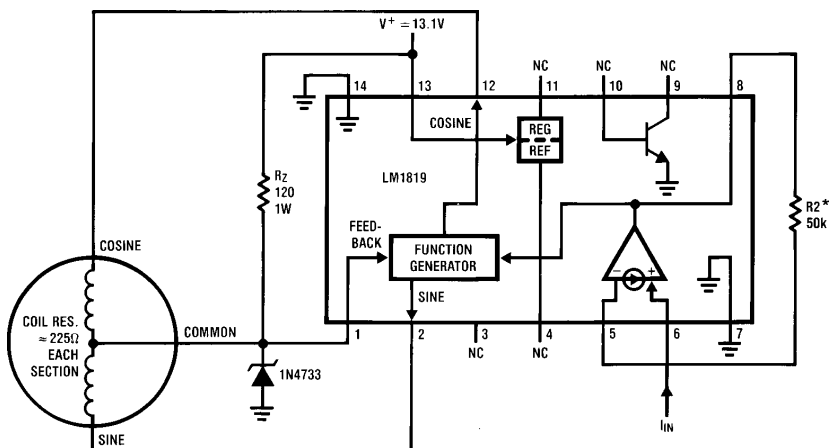

TL/H/5263-7

Deflection = $54R_2 I_{IN}$ (degrees)
 Inputs of 0 to 100 μ A deflect the meter 0 to 270°.
 *Full scale deflection is adjusted by trimming R_2 .

Typical Applications (Continued)

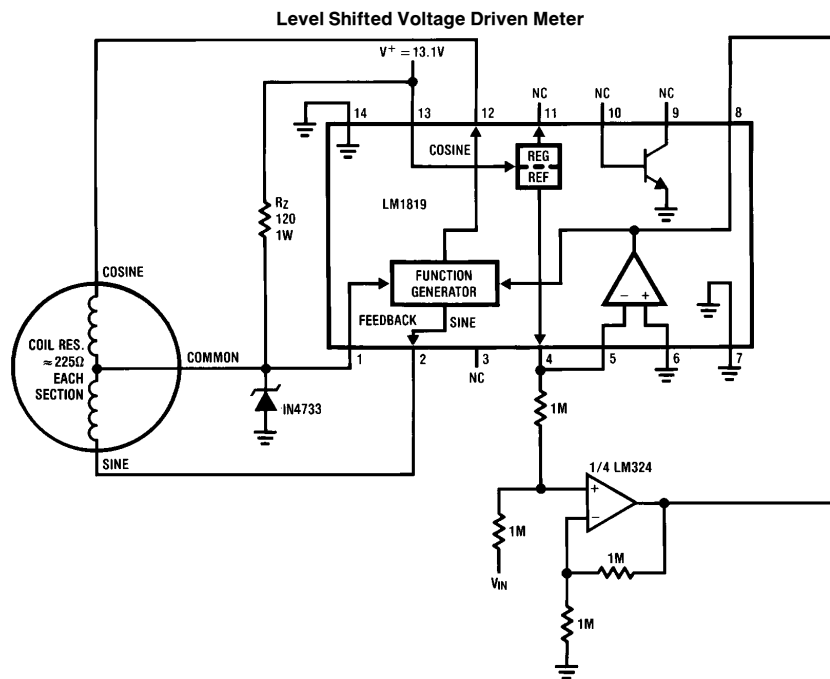

Deflection = $54V_{IN}$ (degrees)

Inputs of 0 to 5.65V deflect the meter through a range of 0 to 305°.

Full scale deflection is adjusted by trimming the input voltage.

TL/H/5263-8

Physical Dimensions inches (millimeters)

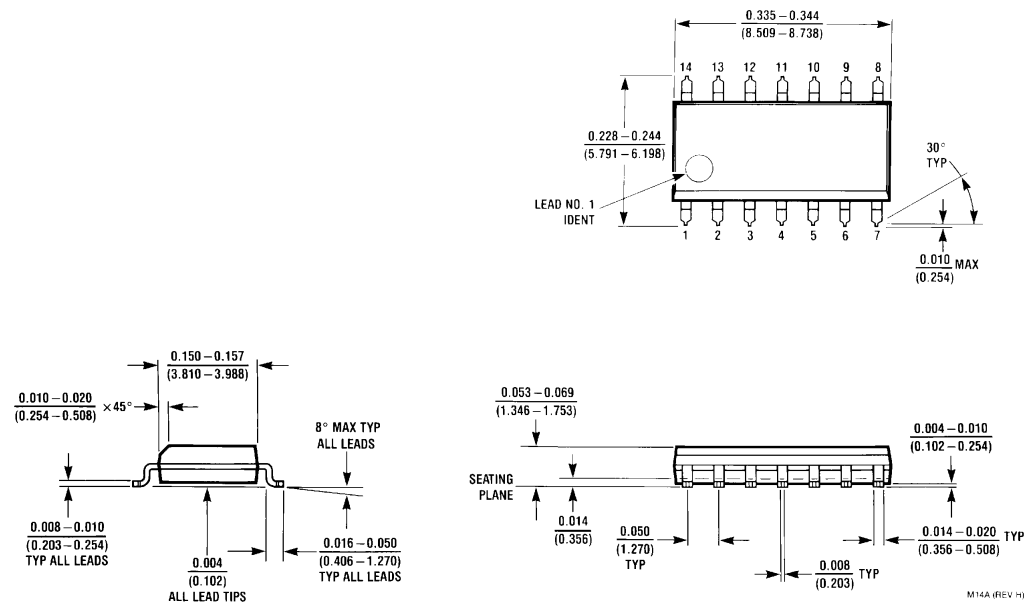

14-Lead (0.150" Wide) Molded Small Outline Package, JEDEC
Order Number LM1819M
NS Package Number M14A

Physical Dimensions inches (millimeters) (Continued)

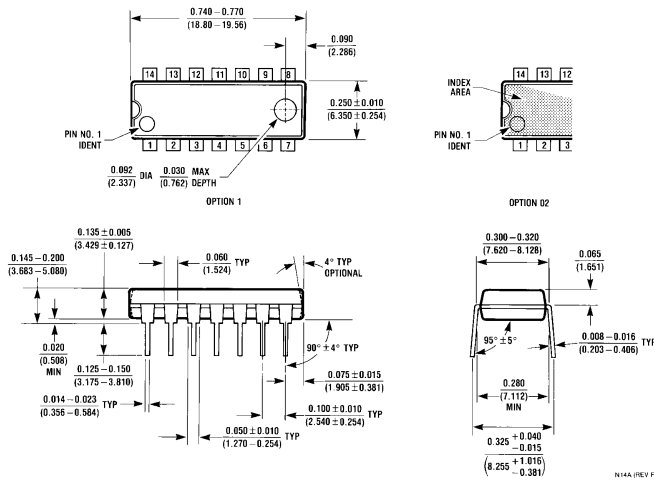

Molded Dual-In-Line Package (N)
Order Number LM1819N
NS Package Number N14A

LIFE SUPPORT POLICY

NATIONAL'S PRODUCTS ARE NOT AUTHORIZED FOR USE AS CRITICAL COMPONENTS IN LIFE SUPPORT DEVICES OR SYSTEMS WITHOUT THE EXPRESS WRITTEN APPROVAL OF THE PRESIDENT OF NATIONAL SEMICONDUCTOR CORPORATION. As used herein:

1. Life support devices or systems are devices or systems which, (a) are intended for surgical implant into the body, or (b) support or sustain life, and whose failure to perform, when properly used in accordance with instructions for use provided in the labeling, can be reasonably expected to result in a significant injury to the user.
2. A critical component is any component of a life support device or system whose failure to perform can be reasonably expected to cause the failure of the life support device or system, or to affect its safety or effectiveness.



National Semiconductor Corporation
 1111 West Bardin Road
 Arlington, TX 76017
 Tel: 1(800) 272-9959
 Fax: 1(800) 737-7018

National Semiconductor Europe
 Fax: (+49) 0-180-530 85 86
 Email: cnjwge@tevm2.nsc.com
 Deutsch Tel: (+49) 0-180-530 85 85
 English Tel: (+49) 0-180-532 78 32
 Français Tel: (+49) 0-180-532 93 58
 Italiano Tel: (+49) 0-180-534 16 80

National Semiconductor Hong Kong Ltd.
 19th Floor, Straight Block,
 Ocean Centre, 5 Canton Rd.
 Tsimshatsui, Kowloon
 Hong Kong
 Tel: (852) 2737-1600
 Fax: (852) 2736-9960

National Semiconductor Japan Ltd.
 Tel: 81-043-299-2309
 Fax: 81-043-299-2408

National does not assume any responsibility for use of any circuitry described, no circuit patent licenses are implied and National reserves the right at any time without notice to change said circuitry and specifications.