

TSL260R, TSL261R, TSL262R

Infrared Light-to-Voltage Optical Sensors

General Description

The TSL260R, TSL261R, and TSL262R are infrared light-to-voltage optical sensors, each combining a photodiode and a transimpedance amplifier (feedback resistor = 16 M Ω , 8 M Ω , and 2.8 M Ω respectively) on a single monolithic IC. Output voltage is directly proportional to the light intensity (irradiance) on the photodiode. These devices have improved amplifier offset-voltage stability and low power consumption and are supplied in a 3-lead plastic sidelooper package with an integral visible light cutoff filter and lens. When supplied in the lead (Pb) free package, the device is RoHS compliant.

Ordering Information and Content Guide appear at end of datasheet.

Key Benefits & Features

The benefits and features of TSL260R, TSL261R, TSL262R, Infrared Light-to-Voltage Optical Sensors are listed below:

Figure 1:
Added Value of Using TSL260R, TSL261R, TSL262R

Benefits	Features
<ul style="list-style-type: none"> Enables Extremely Fast Response to Change 	<ul style="list-style-type: none"> Single Photo-Diode and Trans Impedance Architecture
<ul style="list-style-type: none"> Enables Fast Response to Visible Light in Range of 400nm to 700nm Wavelengths 	<ul style="list-style-type: none"> 260μs Output Rise-Time Response (TSL260R)
<ul style="list-style-type: none"> Provides for High Sensitivity to Detect a Small Change in Light 	<ul style="list-style-type: none"> High Irradiance Responsivity 111mV/(μW/cm²) at λ_p = 940nm (TSL260R)
<ul style="list-style-type: none"> Provides Additional Sensitivity Advantages 	<ul style="list-style-type: none"> 2x Gain Lens

- Integral Visible Light Cutoff Filter
- Monolithic Silicon IC Containing Photodiode, Operational Amplifier, and Feedback Components
- Converts Light Intensity to a Voltage
- Compact 3-Lead Plastic Package
- Single Voltage Supply Operation
- Low Dark (Offset) Voltage....10mV Max
- Low Supply Current.....1.1 mA Typical

- Wide Supply-Voltage Range.... 2.7 V to 5.5 V
- Replacements for TSL260, TSL261, and TSL262
- RoHS Compliant (-LF Package Only)

Functional Block Diagram

The functional blocks of this device are shown below:

Figure 2:
TSL260R, TSL261R, TSL262R Block Diagram

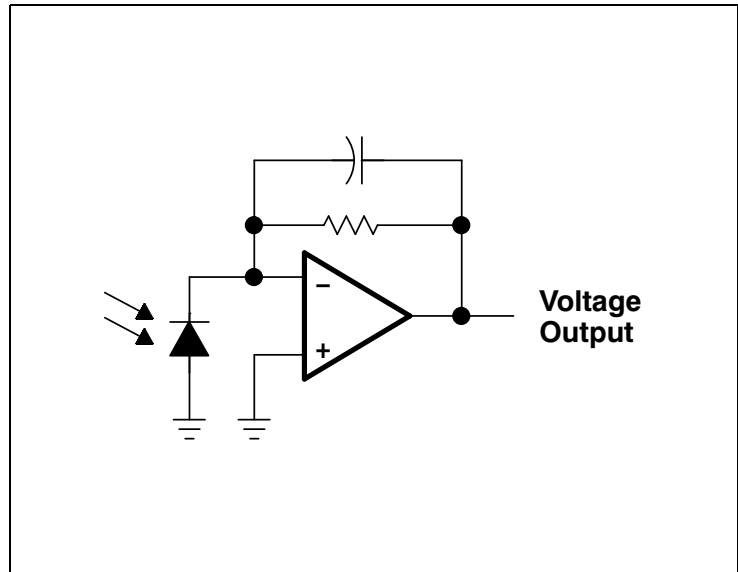

Pin Assignments

Figure 3:
Package S Sidelooker (Front View)

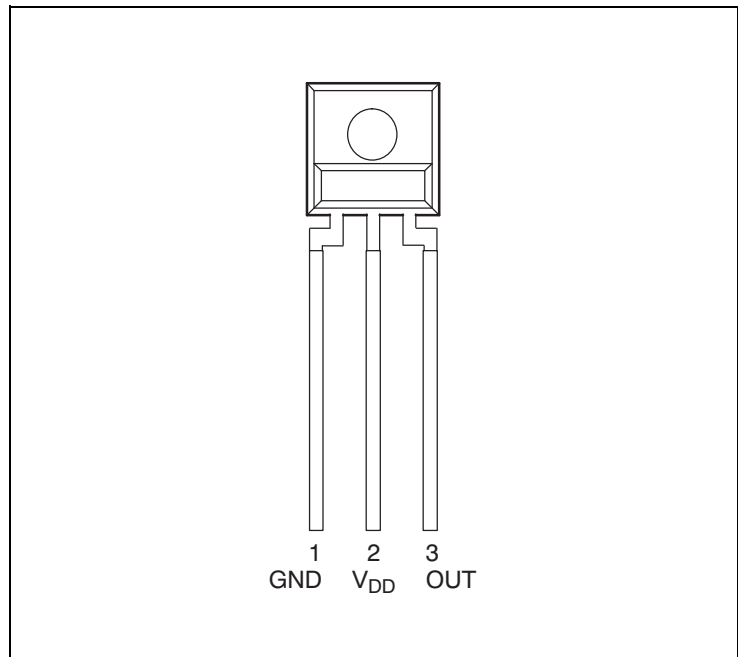

Figure 4:
Package SM Surface Mount Sidelooker (Front View)

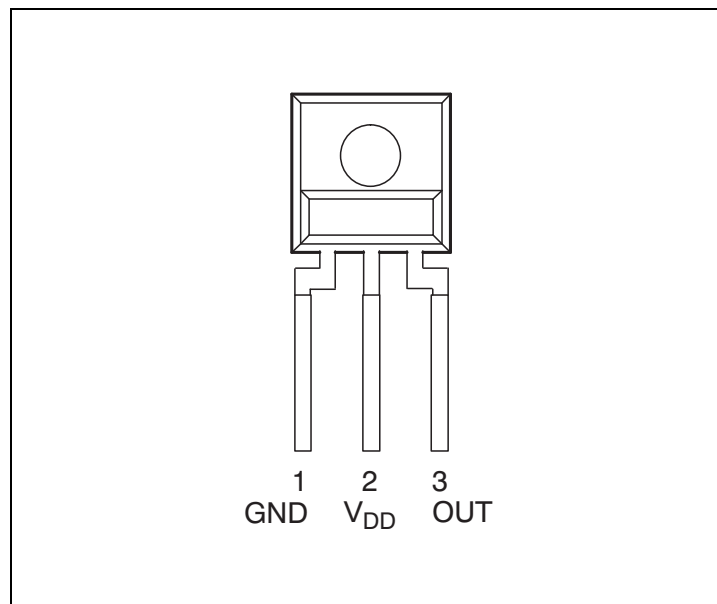

Figure 5:
Terminal Functions

Terminal		Description
Name	No	
GND	1	Ground (substrate). All voltages are referenced to GND.
OUT	3	Output voltage
V _{DD}	2	Supply voltage

Absolute Maximum Ratings

Stresses beyond those listed under [Absolute Maximum Ratings](#) may cause permanent damage to the device. These are stress ratings only, and functional operation of the device at these or any other conditions beyond those indicated under [Recommended Operating Conditions](#) is not implied. Exposure to absolute-maximum-rated conditions for extended periods may affect device reliability.

Figure 6:
Absolute Maximum Ratings Over Operating Free-Air Temperature Range (unless otherwise noted)

Symbol	Parameter	Min	Max	Units
V_{DD}	Supply voltage ⁽¹⁾		6	V
I_O	Output current		±10	mA
	Duration of short-circuit current at (or below) 25°C ⁽²⁾		5	s
T_A	Operating free-air temperature range	-25	85	°C
T_{STRG}	Storage temperature range	-25	85	°C
	Lead temperature 1.6 mm (1/16 inch) from case for 10 seconds (S Package)		260	°C
	Reflow solder, in accordance with J-STD-020C or J-STD-020D (SM Package)		260	°C

Note(s):

1. All voltages are with respect to GND.
2. Output may be shorted to supply.

Figure 7:
Recommended Operating Conditions

Symbol	Parameter	Min	Max	Units
V_{DD}	Supply voltage	2.7	5.5	V
T_A	Operating free-air temperature	0	70	°C

Electrical Characteristics

Electrical Characteristics at $V_{DD} = 5\text{ V}$, $T_A = 25^\circ\text{C}$, $\lambda_p = 940\text{ nm}$, $R_L = 10\text{ k}\Omega$ (unless otherwise noted) see Notes ⁽¹⁾, ⁽²⁾ and ⁽³⁾.

Figure 8:
Electrical Characteristics

Symbol	Parameter	Test Conditions	TSL260R			TSL261R			TSL262R			Unit	
			Min	Typ	Max	Min	Typ	Max	Min	Typ	Max		
V_D	Dark voltage	$E_e = 0$	0	4	10	0	4	10	0	4	10	mV	
V_{OM}	Maximum output voltage	$V_{DD} = 4.5\text{ V}$	3	3.3		3	3.3		3	3.3		V	
V_O	Output voltage	$E_e = 18\ \mu\text{W}/\text{cm}^2$	1	2	3							V	
		$E_e = 46\ \mu\text{W}/\text{cm}^2$				1	2	3					
		$E_e = 220\ \mu\text{W}/\text{cm}^2$							1	2	3		
α_{vo}	Temperature coefficient of output voltage (V_O)	$E_e = 18\ \mu\text{W}/\text{cm}^2$, $T_A = 0^\circ\text{C to } 70^\circ\text{C}$		8								mV/ $^\circ\text{C}$	
				0.4								%/ $^\circ\text{C}$	
		$E_e = 46\ \mu\text{W}/\text{cm}^2$, $T_A = 0^\circ\text{C to } 70^\circ\text{C}$					8						mV/ $^\circ\text{C}$
							0.4						%/ $^\circ\text{C}$
		$E_e = 220\ \mu\text{W}/\text{cm}^2$, $T_A = 0^\circ\text{C to } 70^\circ\text{C}$								8			mV/ $^\circ\text{C}$
										0.4			%/ $^\circ\text{C}$
N_e	Irradiance responsivity	See Note ⁽⁴⁾		111			43.5			9.1		mV/ ($\mu\text{W}/\text{cm}^2$)	

Symbol	Parameter	Test Conditions	TSL260R			TSL261R			TSL262R			Unit
			Min	Typ	Max	Min	Typ	Max	Min	Typ	Max	
I_{DD}	Supply current	$E_e = 18 \mu\text{W}/\text{cm}^2$		1.1	1.7							mA
		$E_e = 46 \mu\text{W}/\text{cm}^2$					1.1	1.7				
		$E_e = 220 \mu\text{W}/\text{cm}^2$								1.1	1.7	

Note(s):

1. Measurements are made with $R_L = 10 \text{ k}\Omega$ between output and ground.
2. Optical measurements are made using small-angle incident radiation from an LED optical source.
3. The input irradiance E_e is supplied by a GaAs LED with peak wavelength $\lambda_p = 940 \text{ nm}$.
4. Irradiance responsivity is characterized over the range $V_O = 0.05$ to 2.9 V . The best-fit straight line of Output Voltage V_O versus irradiance E_e over this range will typically have a positive extrapolated V_O value for $E_e = 0$.

Figure 9:
Dynamic Characteristics at $T_A = 25^\circ\text{C}$ (see [Figure 10](#))

Symbol	Parameter	Test Conditions	TSL260R			TSL261R			TSL262R			Unit
			Min	Typ	Max	Min	Typ	Max	Min	Typ	Max	
t_r	Output pulse rise time	$V_{DD} = 5 \text{ V}, \lambda_p = 940 \text{ nm}$		260			70			7		μs
t_f	Output pulse fall time	$V_{DD} = 5 \text{ V}, \lambda_p = 940 \text{ nm}$		260			70			7		μs
V_n	Output noise voltage	$V_{DD} = 5 \text{ V}, E_e = 0,$ $f = 1000 \text{ Hz}$		0.8			0.7			0.6		$\mu\text{V}/\sqrt{\text{Hz}}$

Parameter Measurement Information

Figure 10:
Switching Times

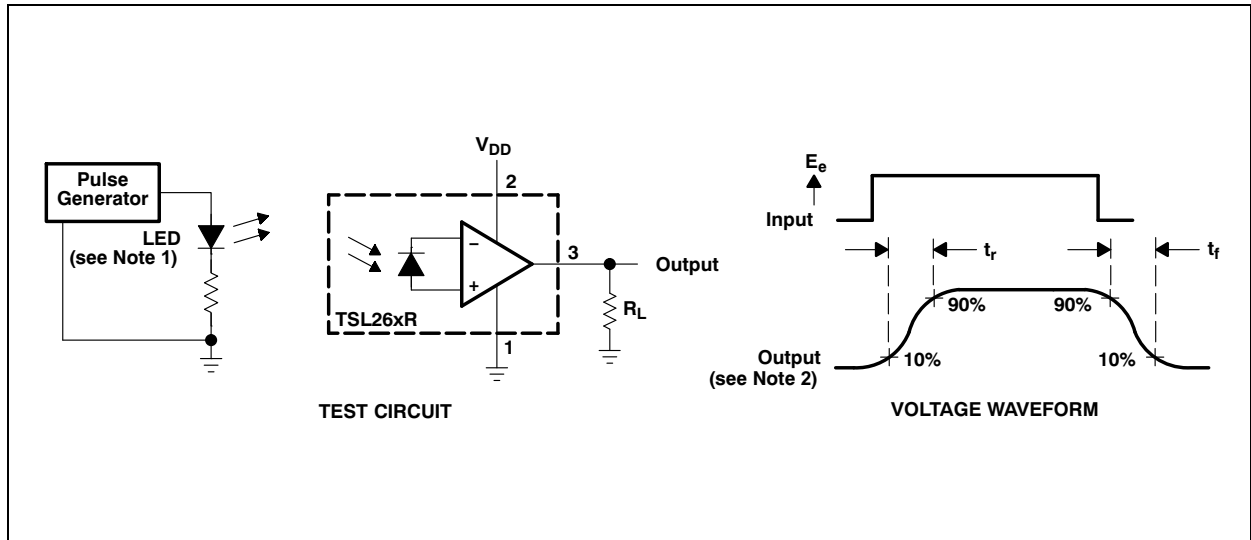

Note(s):

1. The input irradiance is supplied by a pulsed GaAs light-emitting diode with the following characteristics: $\lambda_p = 940 \text{ nm}$, $t_r < 1 \mu\text{s}$, $t_f < 1 \mu\text{s}$.
2. The output waveform is monitored on an oscilloscope with the following characteristics: $t_r < 100 \text{ ns}$, $Z_i \geq 1 \text{ M}\Omega$, $C_i \leq 20 \text{ pF}$.

Typical Operating Characteristics

Figure 11:
Normalized Output Voltage vs Angular Displacement

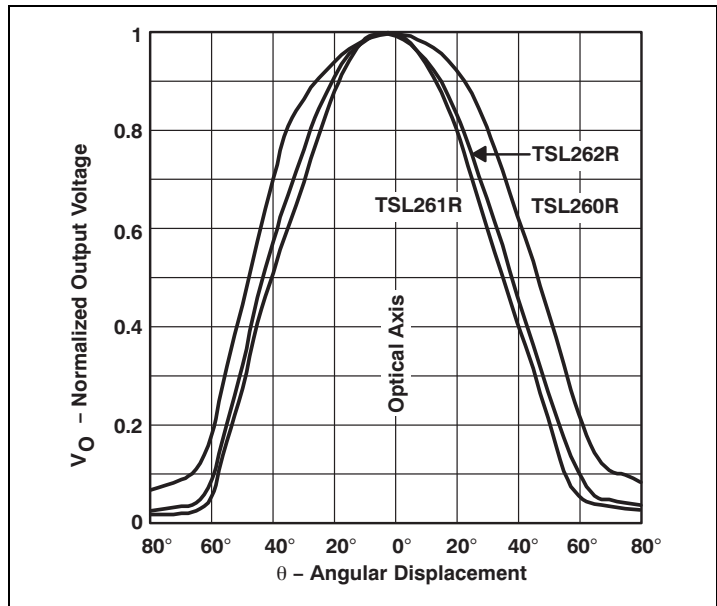

Figure 12:
Output Voltage vs Irradiance

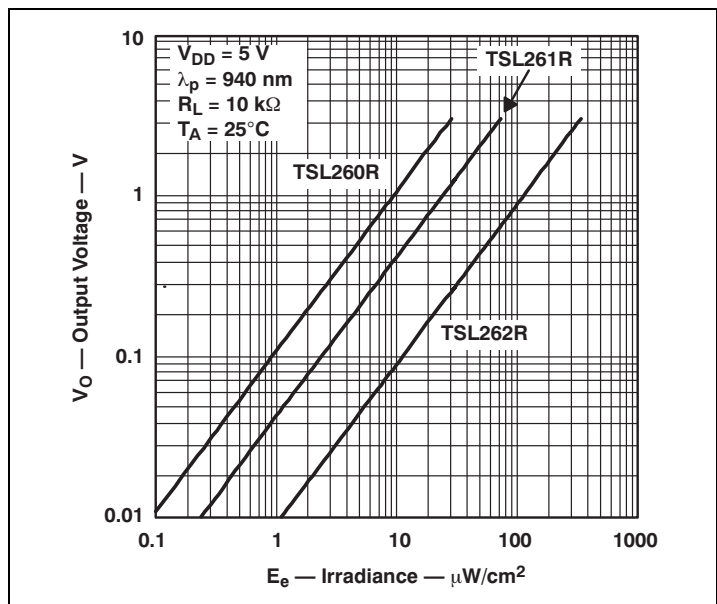

Figure 13:
Photodiode Spectral Responsivity

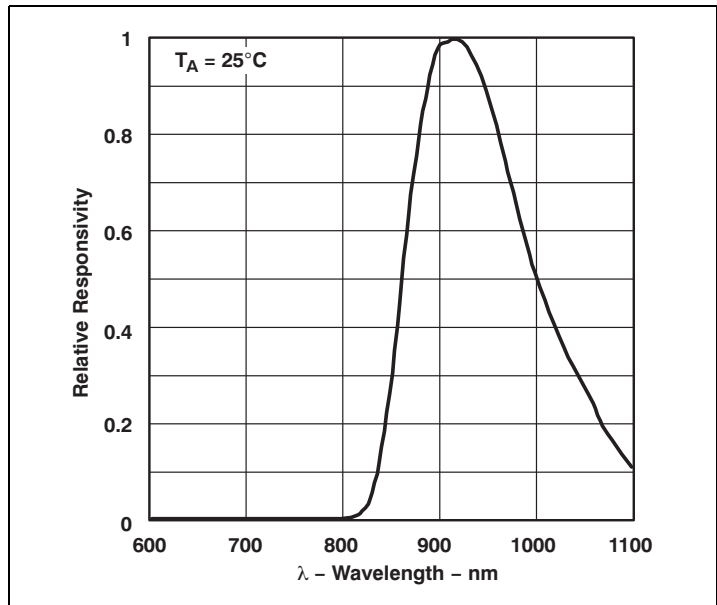

Figure 14:
Maximum Output Voltage vs Supply Voltage

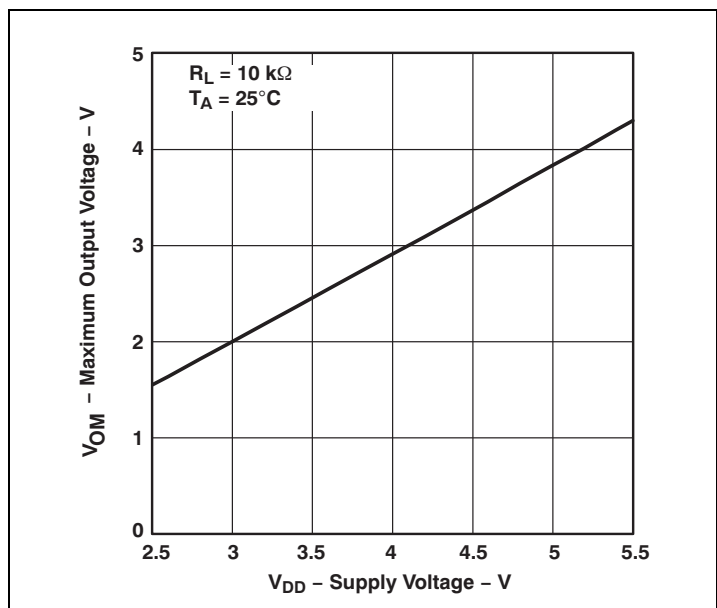
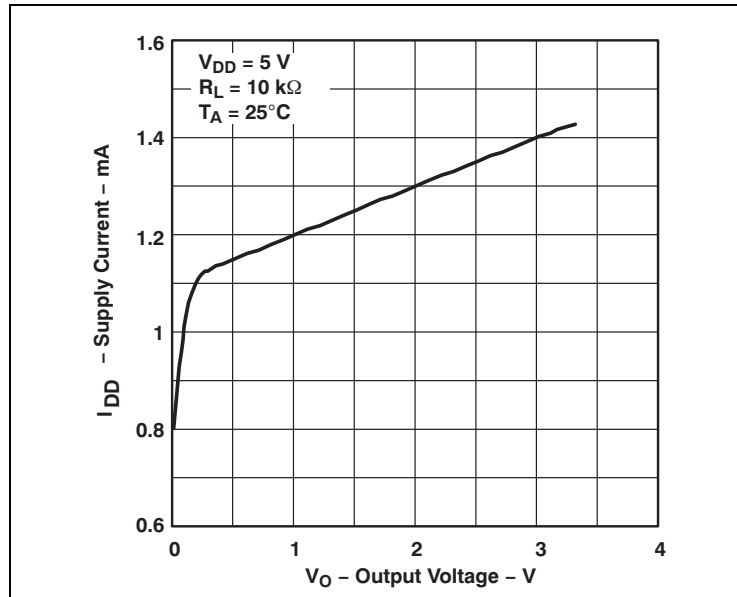
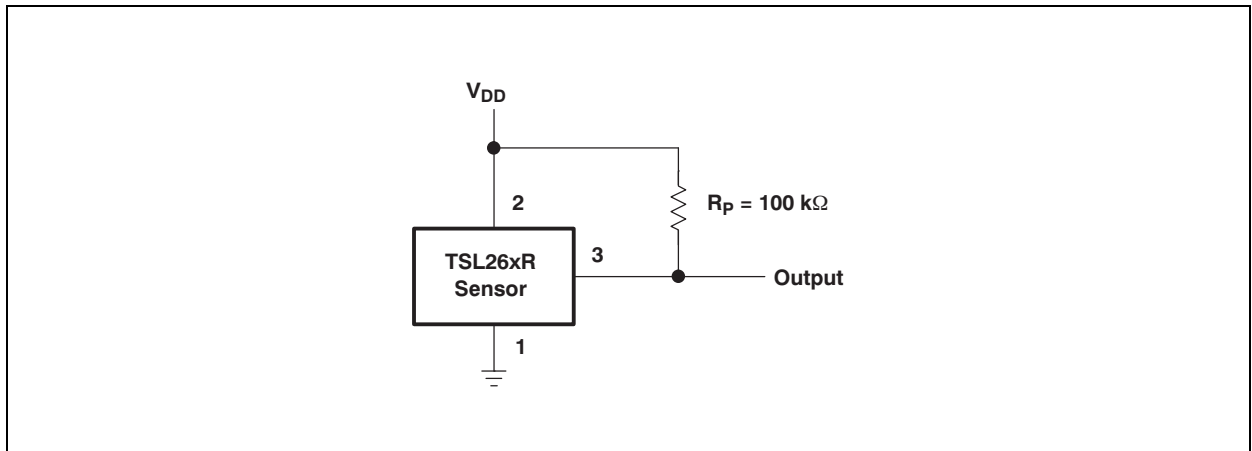

Figure 15:
Supply Current vs Output Voltage



Application Information

Figure 16:
Pullup for Increased V_{OM}



Note(s):

1. Pullup resistor extends linear output range to near V_{DD} with minimal (several millivolts typical) effect on V_{DARK} ; particularly useful at low V_{DD} (3 V to 5 V).

Figure 17:
Short-Range Optical Switch With Hysteresis

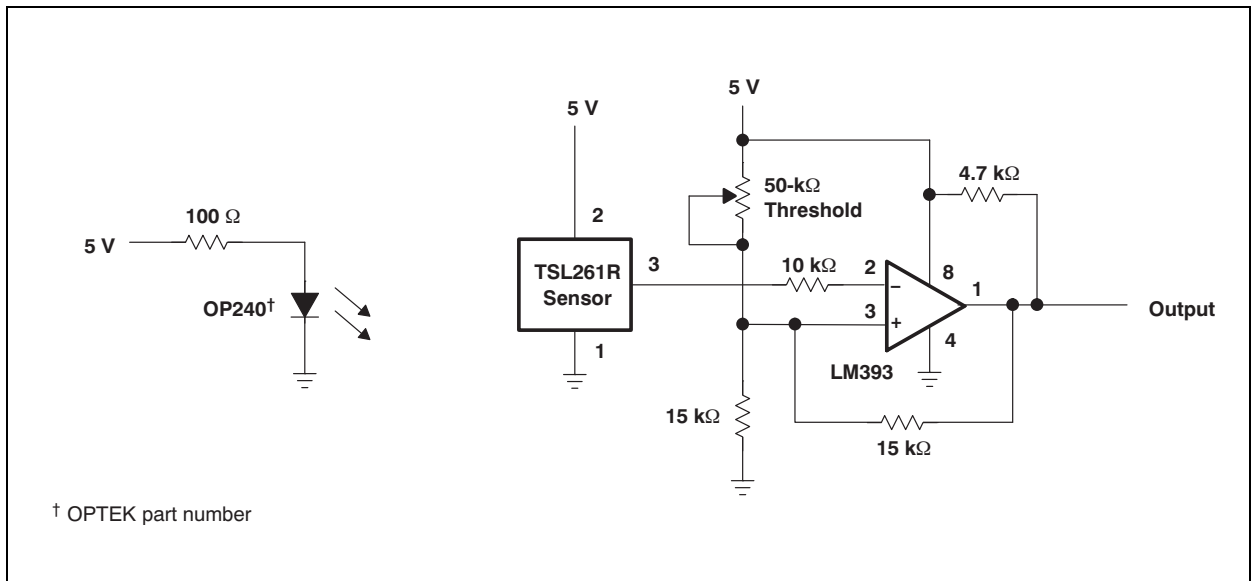

Note(s):

1. Output goes high when beam is interrupted; working distance is several inches or less. Intended for use as optical-interrupter switch or reflective-object sensor.

Figure 18:
Pulsed Optical-Beam Interrupter

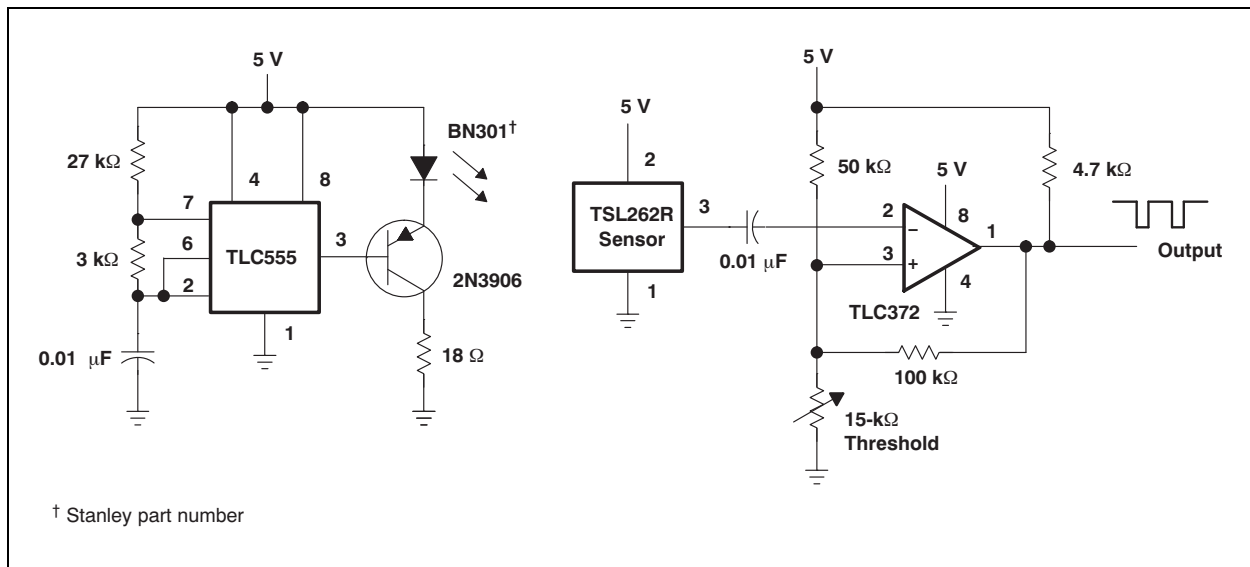

Note(s):

1. Output pulses low until beam is interrupted. Useful range is 1 ft to 20 ft; can be extended with lenses. This configuration is suited for object detection, safety guards, security systems, and automatic doors.

Figure 19:
Proximity Detector

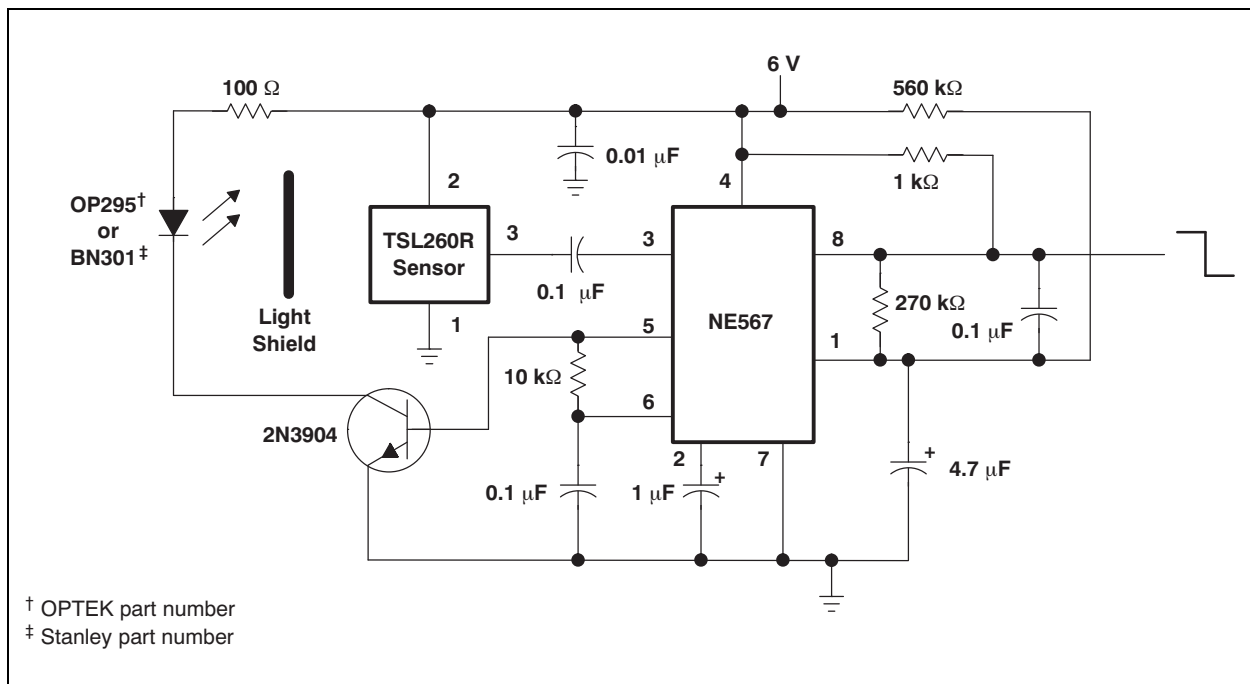

Note(s):

1. Output goes low when light pulses from emitter are reflected back to sensor. Range is 6 in to 18 in depending upon object reflectance. Useful for automatic doors, annunciators, object avoidance in robotics, automatic faucets, and security systems.

Figure 20:
IR Remote Control

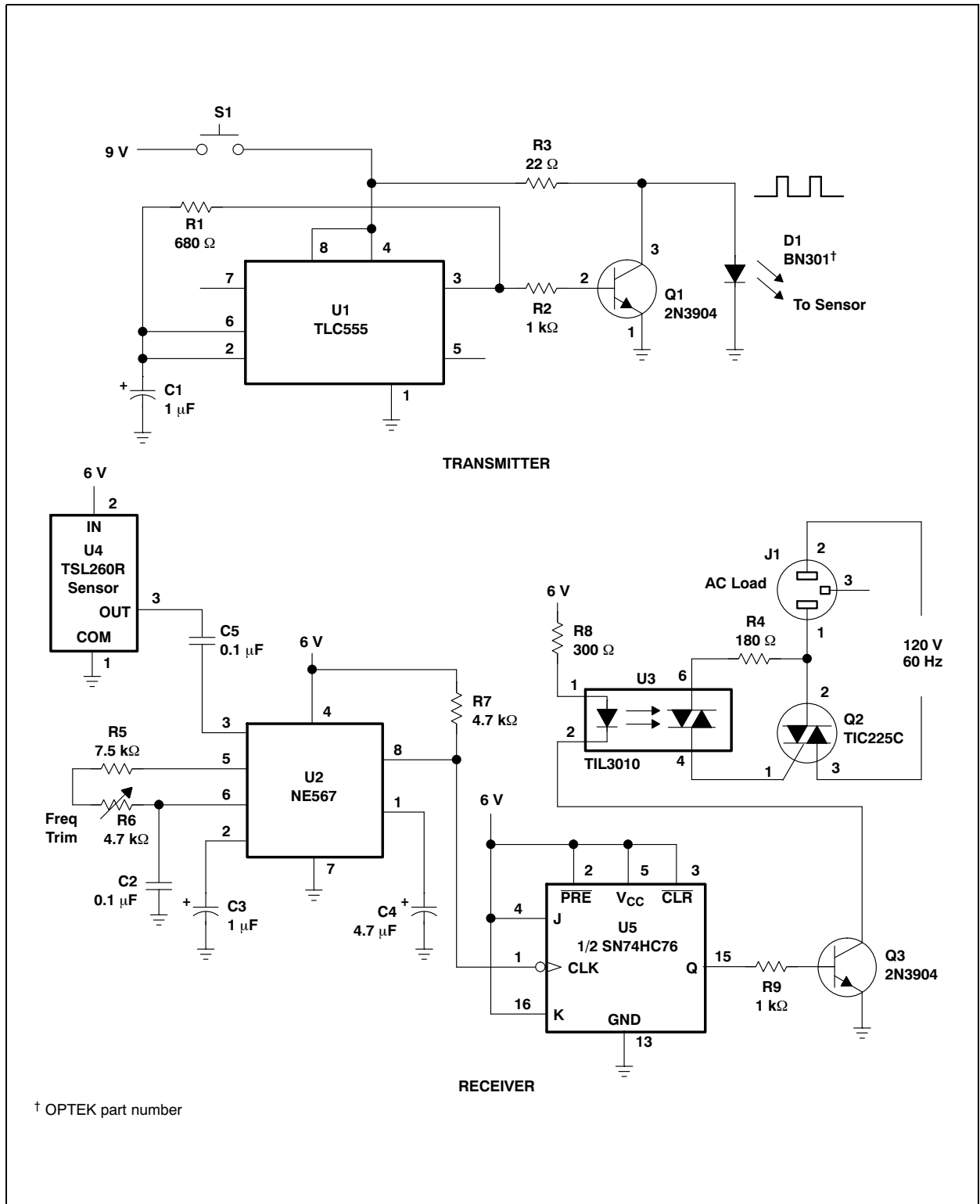

Note(s):

1. Single-channel remote control can be used to switch logic or light dc loads by way of U5 or ac loads by way of the optocoupler and triac as shown. Applications include ceiling fans, lamps, electric heaters, etc.

Figure 21:
IR Voice-Band Audio Link

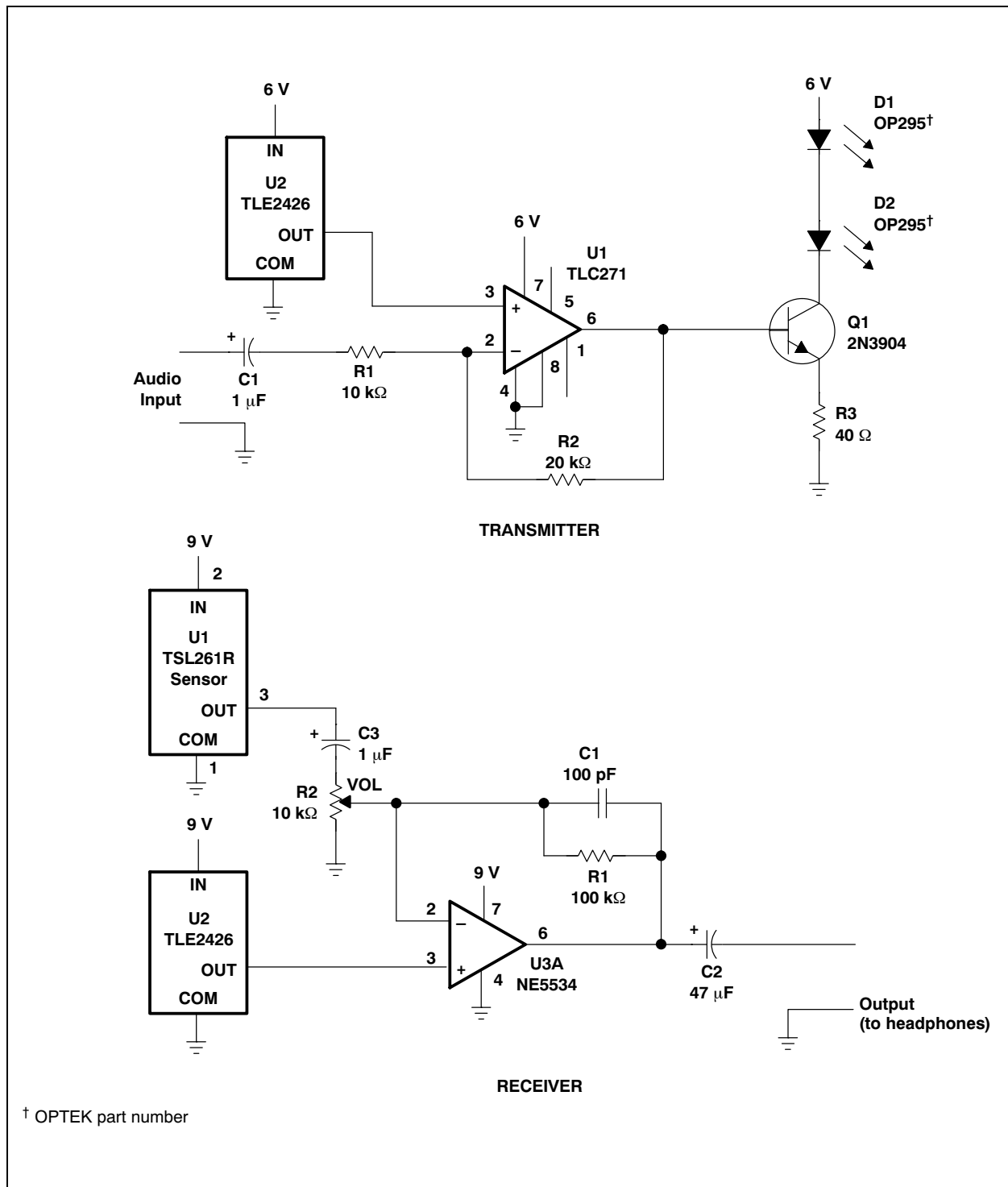

Note(s):

1. Simple transmission of audio signal over short distances (<10 ft). Applications include wireless headphones, wireless-telephone headset, and wireless-headset intercom.

PCB Pad Layout

Suggested PCB pad layout guidelines for the SM surface mount package are shown in [Figure 24](#).

Figure 22:
Suggested SM Package PCB Layout

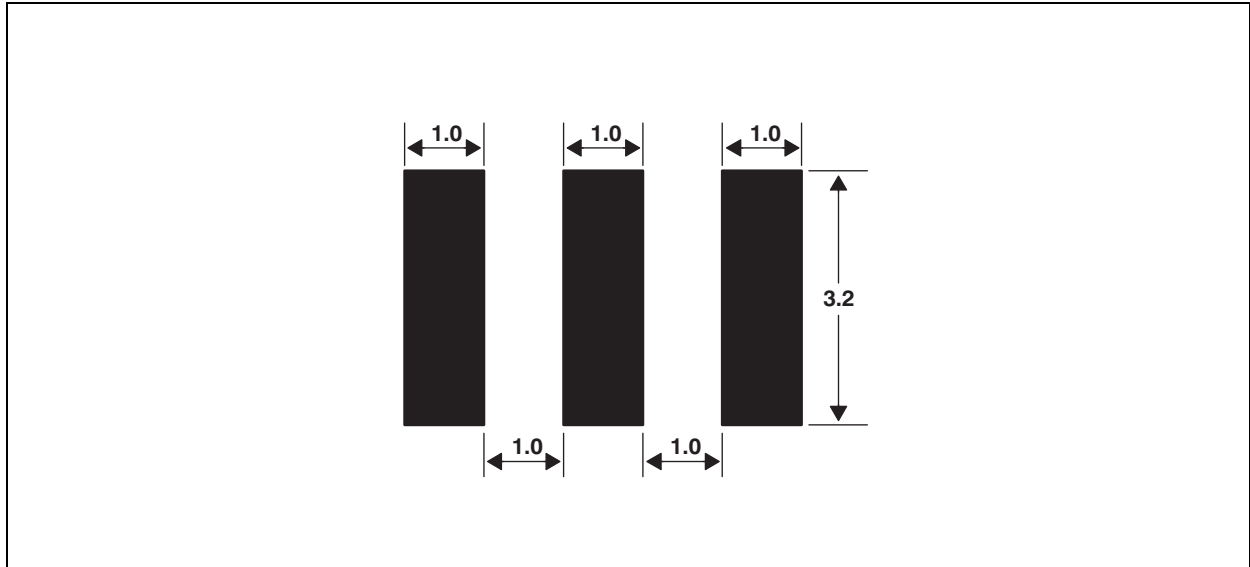

Note(s):

1. All linear dimensions are in millimeters.
2. This drawing is subject to change without notice.

Mechanical Data

The TSL260R, TSL261R, and TSL262R are supplied in a clear 3-lead through-hole package with a molded lens. The integrated photodiode active area is typically 1.0 mm^2 (0.0016 in^2) for TSL260R, 0.5 mm^2 (0.00078 in^2) for the TSL261R, and 0.26 mm^2 (0.0004 in^2) for the TSL262R.

Figure 23:
Package S — Single-In-Line Side-Looker Package Configuration

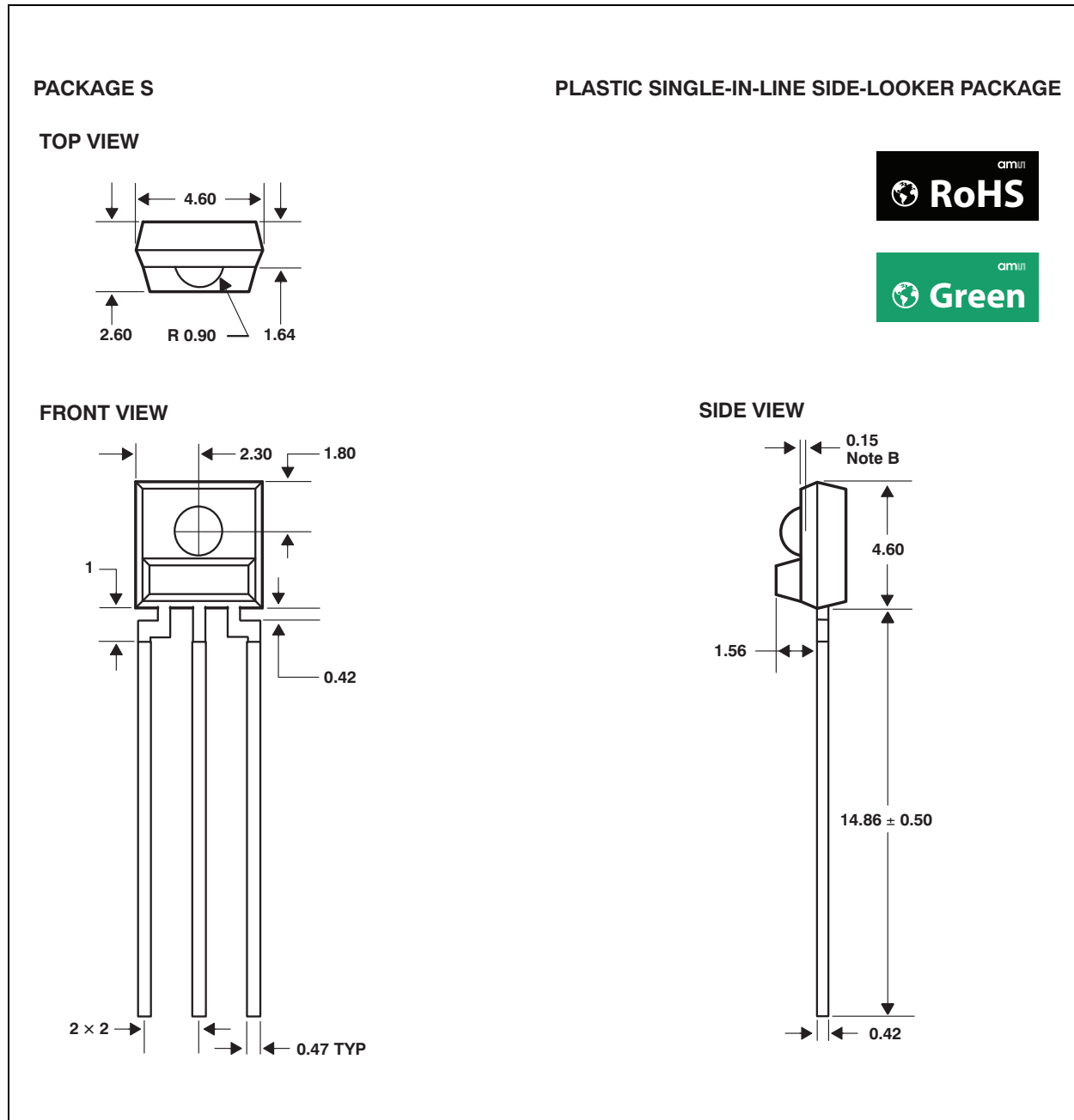

Note(s):

1. All linear dimensions are in millimeters; tolerance is $\pm 0.25 \text{ mm}$ unless otherwise stated.
2. Dimension is to center of lens arc, which is located below the package face.
3. The integrated photodiode active area is typically located in the center of the lens and 0.97 mm below the top of the lens surface.
4. Index of refraction of clear plastic is 1.55.
5. Lead finish for TSL26xR-LF: solder dipped, 100% Sn.
6. This drawing is subject to change without notice.

Figure 24:
Package SM — Surface Mount Side-Looker Package Configuration

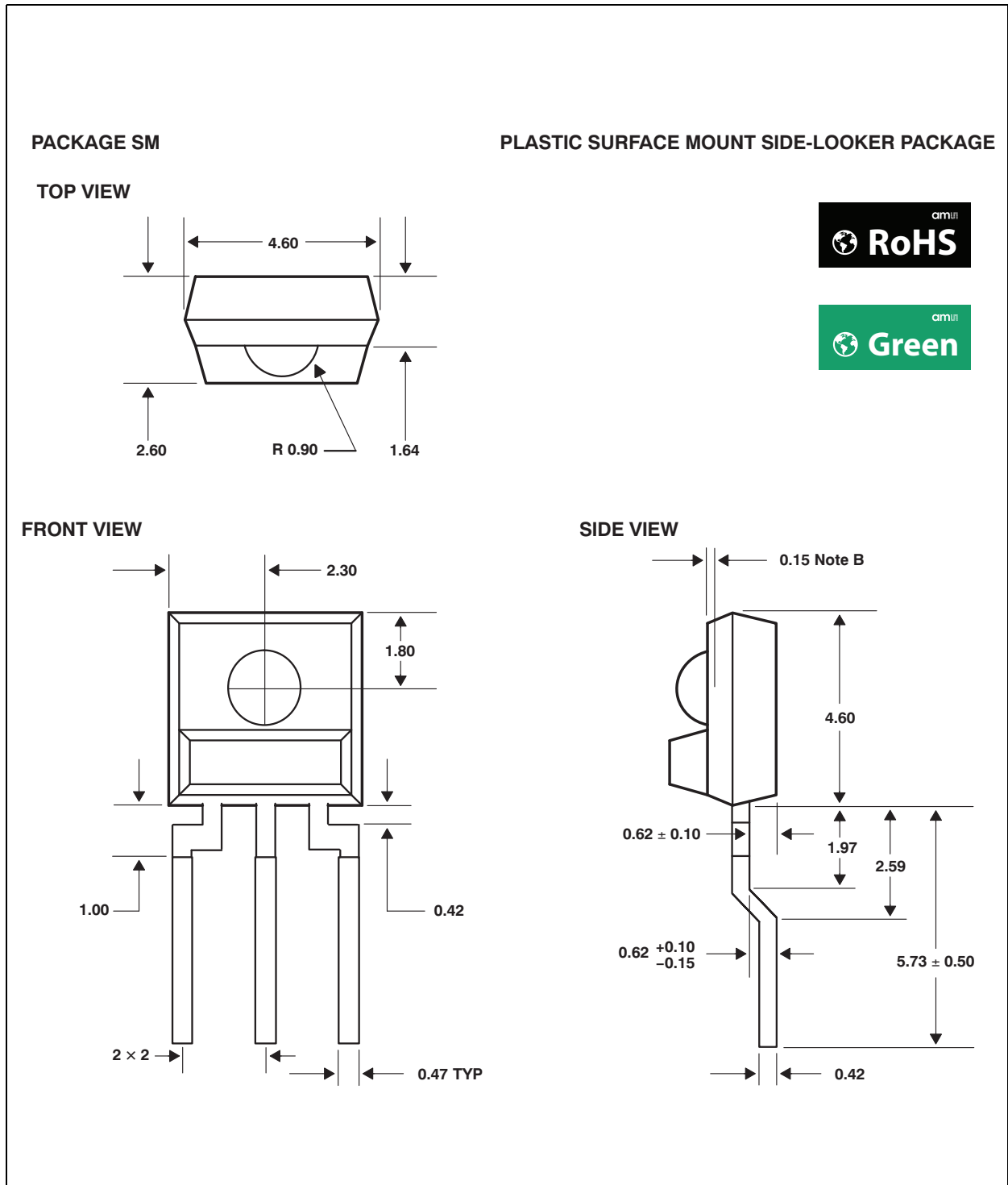

Note(s):

1. All linear dimensions are in millimeters; tolerance is ± 0.25 mm unless otherwise stated.
2. Dimension is to center of lens arc, which is located below the package face.
3. The integrated photodiode active area is typically located in the center of the lens and 0.97 mm below the top of the lens surface.
4. Index of refraction of clear plastic is 1.55.
5. Lead finish for TSL26xRSM-LF: solder dipped, 100% Sn.
6. This drawing is subject to change without notice.

Ordering & Contact Information

Figure 25:
Ordering Information

Ordering Code	Device	T _A	Package – Leads	Package Designator
TSL260R-LF	TSL260R	0°C to 70°C	3-lead Sidelooker — Lead (Pb) Free	S
TSL260RSM-LF	TSL260R	0°C to 70°C	3-lead Surface-Mount Sidelooker — Lead (Pb) Free	SM
TSL261R-LF	TSL261R	0°C to 70°C	3-lead Sidelooker — Lead (Pb) Free	S
TSL261RSM-LF	TSL261R	0°C to 70°C	3-lead Surface-Mount Sidelooker — Lead (Pb) Free	SM
TSL262R-LF	TSL262R	0°C to 70°C	3-lead Sidelooker — Lead (Pb) Free	S
TSL262RSM-LF	TSL262R	0°C to 70°C	3-lead Surface-Mount Sidelooker — Lead (Pb) Free	SM

Buy our products or get free samples online at:
www.ams.com/ICdirect

Technical Support is available at:
www.ams.com/Technical-Support

Provide feedback about this document at:
www.ams.com/Document-Feedback

For further information and requests, e-mail us at:
ams_sales@ams.com

For sales offices, distributors and representatives, please visit:
www.ams.com/contact

Headquarters

ams AG
Tobelbaderstrasse 30
8141 Premstaetten
Austria, Europe

Tel: +43 (0) 3136 500 0

Website: www.ams.com

RoHS Compliant & ams Green Statement

RoHS: The term RoHS compliant means that ams AG products fully comply with current RoHS directives. Our semiconductor products do not contain any chemicals for all 6 substance categories, including the requirement that lead not exceed 0.1% by weight in homogeneous materials. Where designed to be soldered at high temperatures, RoHS compliant products are suitable for use in specified lead-free processes.

ams Green (RoHS compliant and no Sb/Br): ams Green defines that in addition to RoHS compliance, our products are free of Bromine (Br) and Antimony (Sb) based flame retardants (Br or Sb do not exceed 0.1% by weight in homogeneous material).

Important Information: The information provided in this statement represents ams AG knowledge and belief as of the date that it is provided. ams AG bases its knowledge and belief on information provided by third parties, and makes no representation or warranty as to the accuracy of such information. Efforts are underway to better integrate information from third parties. ams AG has taken and continues to take reasonable steps to provide representative and accurate information but may not have conducted destructive testing or chemical analysis on incoming materials and chemicals. ams AG and ams AG suppliers consider certain information to be proprietary, and thus CAS numbers and other limited information may not be available for release.

Copyrights & Disclaimer

Copyright ams AG, Tobelbader Strasse 30, 8141 Premstaetten, Austria-Europe. Trademarks Registered. All rights reserved. The material herein may not be reproduced, adapted, merged, translated, stored, or used without the prior written consent of the copyright owner.

Devices sold by ams AG are covered by the warranty and patent indemnification provisions appearing in its General Terms of Trade. ams AG makes no warranty, express, statutory, implied, or by description regarding the information set forth herein. ams AG reserves the right to change specifications and prices at any time and without notice. Therefore, prior to designing this product into a system, it is necessary to check with ams AG for current information. This product is intended for use in commercial applications. Applications requiring extended temperature range, unusual environmental requirements, or high reliability applications, such as military, medical life-support or life-sustaining equipment are specifically not recommended without additional processing by ams AG for each application. This product is provided by ams AG "AS IS" and any express or implied warranties, including, but not limited to the implied warranties of merchantability and fitness for a particular purpose are disclaimed.

ams AG shall not be liable to recipient or any third party for any damages, including but not limited to personal injury, property damage, loss of profits, loss of use, interruption of business or indirect, special, incidental or consequential damages, of any kind, in connection with or arising out of the furnishing, performance or use of the technical data herein. No obligation or liability to recipient or any third party shall arise or flow out of ams AG rendering of technical or other services.

Document Status

Document Status	Product Status	Definition
Product Preview	Pre-Development	Information in this datasheet is based on product ideas in the planning phase of development. All specifications are design goals without any warranty and are subject to change without notice
Preliminary Datasheet	Pre-Production	Information in this datasheet is based on products in the design, validation or qualification phase of development. The performance and parameters shown in this document are preliminary without any warranty and are subject to change without notice
Datasheet	Production	Information in this datasheet is based on products in ramp-up to full production or full production which conform to specifications in accordance with the terms of ams AG standard warranty as given in the General Terms of Trade
Datasheet (discontinued)	Discontinued	Information in this datasheet is based on products which conform to specifications in accordance with the terms of ams AG standard warranty as given in the General Terms of Trade, but these products have been superseded and should not be used for new designs

Revision Information

Changes from 049E (2007-Sep) to current revision 1-00 (2016-Jul-05)	Page
Content of TAOS datasheet was updated to latest ams design	
Updated Key Benefits & Features section	1
Updated note under Figure 23	17
Updated Figure 25	19

Note(s):

1. Page and figure numbers for the previous version may differ from page and figure numbers in the current revision.
2. Correction of typographical errors is not explicitly mentioned.

Content Guide

1	General Description
1	Key Benefits & Features
2	Functional Block Diagram
3	Pin Assignments
5	Absolute Maximum Ratings
6	Electrical Characteristics
8	Parameter Measurement Information
9	Typical Operating Characteristics
12	Application Information
16	PCB Pad Layout
17	Mechanical Data
19	Ordering & Contact Information
20	RoHS Compliant & ams Green Statement
21	Copyrights & Disclaimer
22	Document Status
23	Revision Information