

Features and Benefits

- Absolute Rotary Position Sensor IC
- Tria \otimes is $\text{\textcircled{R}}$ Hall Technology
- Hi-Speed Operation
- Sine/Cosine Outputs
- Simple & Robust Magnetic Design
- Excellent Thermal Stability
- Very Low Hysteresis
- SOIC-8 Package (RoHS)

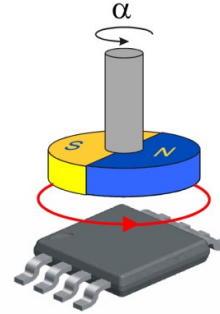

Applications

- Absolute Rotary Position Sensor
- BLDC Motor Position Sensor (for Commutation)
- Contactless potentiometers
- Contactless encoder



Ordering Code

| Part No. | Temperature Code | Package Code | Option code | Packing Form |
|----------|------------------|--------------|-------------|--------------|
| MLX91204 | K | DC | ABA-001 | RE |
| MLX91204 | K | DC | ABA-002 | RE |
| MLX91204 | K | DC | ABA-003 | RE |
| MLX91204 | K | DC | ABA-001 | TU |
| MLX91204 | K | DC | ABA-002 | TU |
| MLX91204 | K | DC | ABA-003 | TU |

Legend:

Temperature Code: K for Temperature Range -40°C to 125°C
 Package Code: DC for SOIC-8 Package
 Option Code: Magnetic Sensitivity - See Section 7: parameter sensitivity=> test conditions;
 parameter Full scale magnetic field range=> test conditions
 Packing Form: RE for Reel
 TU for Tube

Ordering example: MLX91204KDC-ABA-001-RE

1 Functional Diagram

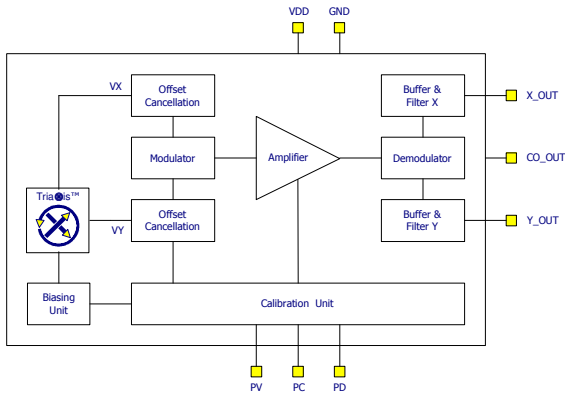

2 General Description

The Tria[®]is[®] rotary position sensor MLX91204 detects the absolute angular position of a small magnet that is positioned above the device surface.

The MLX91204 reports two analog, linear, orthogonal (quadrature) and ratiometric output voltages proportional to the applied magnetic flux density parallel to the chip surface (thanks to the Integrated Magneto Concentrator – IMC[®] – added on the top of the sensitive Hall elements).

The MLX91204 is ideally suited for hi-speed rotary position sensing in harsh automotive and industrial environments.

The angular position is computed off-chip from both sine and cosine signals.



MLX91204

360 Degrees Hi-Speed Rotary Position Sensor (Sine/Cosine)

Table of Contents

| | | |
|------|--|----|
| 1 | Functional Diagram | 2 |
| 2 | General Description | 2 |
| 3 | Glossary of Terms..... | 4 |
| 4 | Absolute Maximum Ratings..... | 4 |
| 5 | Pinout and Function..... | 4 |
| 6 | MLX91204 General Electrical Specification..... | 5 |
| 7 | MLX91204 Sensor Specification | 5 |
| 8 | Application Diagram | 7 |
| 8.1 | Single Ended Mode..... | 7 |
| 8.2 | Differential Mode | 7 |
| 9 | Standard information regarding manufacturability of Melexis products with different soldering processes..... | 8 |
| 10 | ESD Precautions..... | 9 |
| 11 | Package Information | 9 |
| 11.1 | Package Dimensions | 9 |
| 11.2 | Pinout and Marking | 10 |
| 11.3 | Hall Plate Positioning..... | 10 |
| 12 | Disclaimer | 11 |

3 Glossary of Terms

- Gauss (G), Tesla (T): Magnetic flux density units where 1 mT = 10 G.
- Tria@is®: This technology refers to the Melexis Hall technology which allows the realization of Hall effect sensors able to sense the flux density along the 3 axis (i.e. X, Y & Z). In particular, it enables the realization of position sensors able to sense the magnetic flux density parallel to the IC surface and consequently the magnetic vector over 360 degrees.
- IMC: Integrated Magneto Concentrator. It concentrates the magnetic flux lines and bends them at the extremity under the planar Hall plates. Furthermore, it provides some magnetic gain factor.

4 Absolute Maximum Ratings

| Parameter. | Units |
|---|--------------------|
| Supply Voltage, V _{DD} (overvoltage) | + 6 V |
| Reverse Voltage Protection | - 0.5 V |
| Operating Temperature Range TA | -40 to +125 Deg.C. |
| Storage Temperature Range, TS | -40 to +150 Deg.C. |

Exceeding the absolute maximum ratings may cause permanent damage. Exposure to absolute-maximum-rated conditions for extended periods may affect device reliability.

5 Pinout and Function

| Pin # | Pin Name | Function |
|-------|-----------------|---|
| 1 | CO_OUT | Output Common (V _{DD} /2) |
| 2 | PC | Factory programming pin. Connect to V _{DD} |
| 3 | V _{DD} | Supply Voltage (+) |
| 4 | Y_OUT | Analog Output Y |
| 5 | X_OUT | Analog Output X |
| 6 | PD | Factory programming pin. Connect to G _{ND} |
| 7 | PV | Factory programming pin. Connect to V _{DD} |
| 8 | G _{ND} | Ground |

6 MLX91204 General Electrical Specification

DC Operating Parameters $T_A = -40$ Deg.C. to $+125$ Deg.C., $V_{DD} = 5.0$ V (unless otherwise specified)

| Parameter | Symbol | Test Conditions | Min | Typ | Max | Units |
|---|---------------|------------------------------------|-----|------|------|------------|
| Nominal Supply Voltage | V_{DD} | | 4.5 | 5 | 5.5 | V |
| Supply Current | I_{DD} | $I_{OUT} = 0$ mA | | 16.5 | 19 | mA |
| Common Output | CO_{OUT} | Referring to $V_{DD}/2$, unloaded | - 2 | 0 | 2 | % V_{DD} |
| Output Current CO_{OUT} and X_{OUT} and Y_{OUT} | I_{OUT} | Drop is typically 80mV/mA | - 1 | | 1 | mA |
| Output Load Resistance | R_L | | 5 | | | k Ω |
| Output Load Capacitance | C_L | | | | 1000 | pF |
| Start-up cycle | $t_{STARTUP}$ | | | 150 | 200 | μ s |

7 MLX91204 Sensor Specification

DC Operating Parameters $T_A = -40$ Deg.C. to 125 Deg.C., $V_{DD} = 5.0$ V, differential output (unless otherwise specified)

| Parameter | Symbol | Test Conditions | Min | Typ | Max | Units |
|---|---------------------------|--|--------|---------|-------|----------------------|
| Offset Voltage | V_{OQ} | $T_A = 25$ Deg.C. - $B = 0$ mT X_{OUT} & Y_{OUT} | -10 | 0 | 10 | mV |
| Offset Temperature Drift | $\Delta V_{OQ}/\Delta T$ | $B = 0$ mT - X_{OUT} & Y_{OUT} ⁽¹⁾ | -0.10 | 0 | +0.10 | mV/Deg.C. |
| Sensitivity | S | $T = 25$ Deg.C. Option Code : ABA-001 | 16 | 25 | 34 | V/T |
| | | $T = 25$ Deg.C. Option Code : ABA-002 | 32 | 50 | 68 | V/T |
| | | $T = 25$ Deg.C. Option Code : ABA-003 | 64 | 100 | 136 | V/T |
| Sensitivity Temperature Drift | $\Delta S/[\Delta T]$ | ⁽¹⁾ | -0.08 | -0.05 | -0.01 | %/Deg.C. |
| Sensitivity Mismatch | S_{XY} | $S_{XY} = S_X/S_Y$ | -3 | 0 | 3 | % |
| Sensitivity Mismatch Temperature Drift | $\Delta(S_{XY})/\Delta T$ | ⁽¹⁾ | -0.012 | 0 | 0.012 | %/Deg.C. |
| Phase Mismatch | $\angle S_X - \angle S_Y$ | | -1 | 0 | 1 | Degree |
| Hysteresis | HYST | ⁽¹⁾ | -20 | ± 8 | 20 | μ T |
| Full Scale Magnetic Field Range (± 2 V Output Swing) | B_{FS} | Option Code: ABA-001 | | | 58.8 | mT |
| | | Option Code: ABA-002 | | | 29.4 | mT |
| | | Option Code: ABA-003 | | | 14.7 | mT |
| Max. Output Voltage Swing | V_{OUTMAX} | $B > B_{FS}$ - X_{OUT} & Y_{OUT} $I_{OUT} = 0$ mA | 0.25 | | 4.75 | V |
| Angular Speed | ω | 2 poles magnet | | | 100k | RPM |
| Bandwidth (-3dB) DC to | BW | $R_L > 1$ M Ω - $C_L < 10$ pF | | 15 | | kHz |
| Spectral Noise Density | ΔB_{NOISE} | | | | 750 | nT/Hz ^{1/2} |

(1) Characterized

360 Degrees Hi-Speed Rotary Position Sensor (Sine/Cosine)

From the previous table and the ageing data, the intrinsic angular linearity error (in Degree) can be derived from the individual contributions as it follows:

| Test Conditions | Parameters | Output Swing | | Unit |
|--|----------------------|---------------|---------------|---------------|
| | | ± 1 V | ± 2 V | |
| Room Temperature (T _A = 25 Deg.C.) | Offset | ± 0.8 | ± 0.4 | Degree |
| | Sensitivity Mismatch | ± 0.84 | ± 0.84 | Degree |
| | Phase Mismatch | ± 1 | ± 1 | Degree |
| | Total | ± 2.64 | ± 2.24 | Degree |
| Temperature Range (T _A = -40 ... 125 Deg.C.) | Offset | ± 0.8 | ± 0.4 | Degree |
| | Sensitivity Mismatch | ± 0.34 | ± 0.34 | Degree |
| | Phase Mismatch | ± 0.12 | ± 0.12 | Degree |
| | Total | ± 1.26 | ± 0.86 | Degree |
| Lifetime/Ageing (HTOL 1000 hours - 5.0 V - 150 Deg.C.) | Offset | ± 0.8 | ± 0.4 | Degree |
| | Sensitivity Mismatch | ± 0.1 | ± 0.1 | Degree |
| | Phase Mismatch | ± 0.1 | ± 0.1 | Degree |
| | Total | ± 1.00 | ± 0.60 | Degree |
| Overall Linearity Error | Excl. Ageing | ± 3.90 | ± 3.10 | Degree |
| | Incl. Ageing | ± 4.90 | ± 3.70 | Degree |

The intrinsic linearity error refers only to the linearity error associated to the MLX91204. The linearity error associated to the magnetic and mechanical (off-axis, excentricity) design is not included and should be considered as an additional contribution.

For more information, please refer to the application note:

http://www.melexis.com/Assets/Magnet_Application_Note_MLX90316_5221.aspx

The total error can be reduced either statically (room temperature compensation) or dynamically (continuous compensation) through the off-chip signal processing performing the angular computation i.e. $\arctan(Y_{OUT}/X_{OUT})$. The compensation is applied prior to computing the arctangent function: offset, gain and phase correction can be applied.

For more information, please refer to the application note:

http://www.melexis.com/Assets/Front-End_Calibration_of_MLX90316_5252.aspx

8 Application Diagram

8.1 Single Ended Mode

The output voltages $X = (X_OUT - GND)$ and $Y = (Y_OUT - GND)$ are within 0.5V to 4.5V with an offset of 2.5V ($V_{DD}/2$)

For reliable operation within the specifications the sensor must be connected as follows:

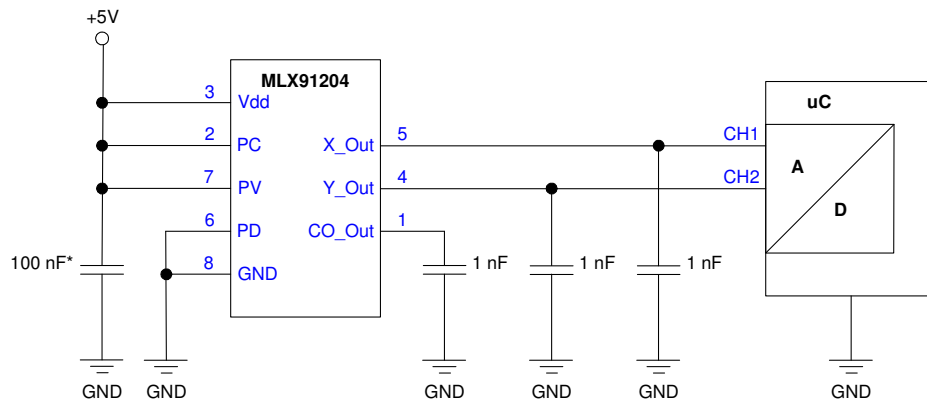

* if the supply voltage is disturbed by EMI it can be useful to place a second capacitor (100 pF ceramic) parallel to the 100nF capacitor.

8.2 Differential Mode

The output voltages $X = (X_OUT - CO_OUT)$ and $Y = (Y_OUT - CO_OUT)$ are within ± 2 V around "virtual ground" (i.e. $CO_OUT = 2.5V = V_{DD}/2$)

For reliable operation within the specifications the sensor must be connected as follows:

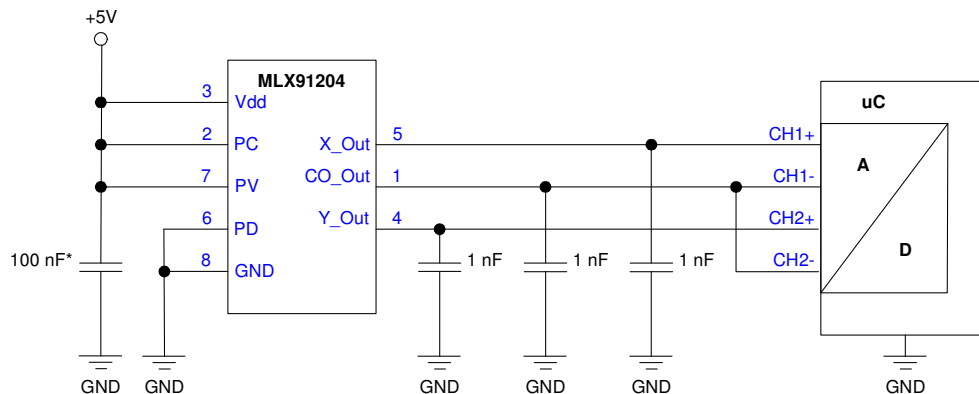

* if the supply voltage is disturbed by EMI it can be useful to place a second capacitor (100pF ceramic) parallel to the 100 nF capacitor.

9 Standard information regarding manufacturability of Melexis products with different soldering processes

Our products are classified and qualified regarding soldering technology, solderability and moisture sensitivity level according to following test methods:

Reflow Soldering SMD's (Surface Mount Devices)

IPC/JEDEC J-STD-020

Moisture/Reflow Sensitivity Classification for Nonhermetic Solid State Surface Mount Devices
(Classification reflow profiles according to table 5-2)

EIA/JEDEC JESD22-A113

Preconditioning of Nonhermetic Surface Mount Devices Prior to Reliability Testing
(Reflow profiles according to table 2)

Melexis Working Instruction 341901308

Wave Soldering SMD's (Surface Mount Devices) and THD's (Through Hole Devices)

- EN60749-20
Resistance of plastic- encapsulated SMD's to combined effect of moisture and soldering heat
- EIA/JEDEC JESD22-B106 and EN60749-15
Resistance to soldering temperature for through-hole mounted devices
- Melexis Working Instruction 341901309

Iron Soldering THD's (Through Hole Devices)

- EN60749-15
Resistance to soldering temperature for through-hole mounted devices
- Melexis Working Instruction 341901309

Solderability SMD's (Surface Mount Devices) and THD's (Through Hole Devices)

- EIA/JEDEC JESD22-B102 and EN60749-21
Solderability
- Melexis Working Instruction 3304312

For all soldering technologies deviating from above mentioned standard conditions (regarding peak temperature, temperature gradient, temperature profile etc) additional classification and qualification tests have to be agreed upon with Melexis.

The application of Wave Soldering for SMD's is allowed only after consulting Melexis regarding assurance of adhesive strength between device and board.

For more information on the lead free topic please see quality page at our website:

<http://www.melexis.com/quality.aspx>

10 ESD Precautions

Electronic semiconductor products are sensitive to Electro Static Discharge (ESD). Always observe Electro Static Discharge control procedures whenever handling semiconductor products.

11 Package Information

11.1 Package Dimensions

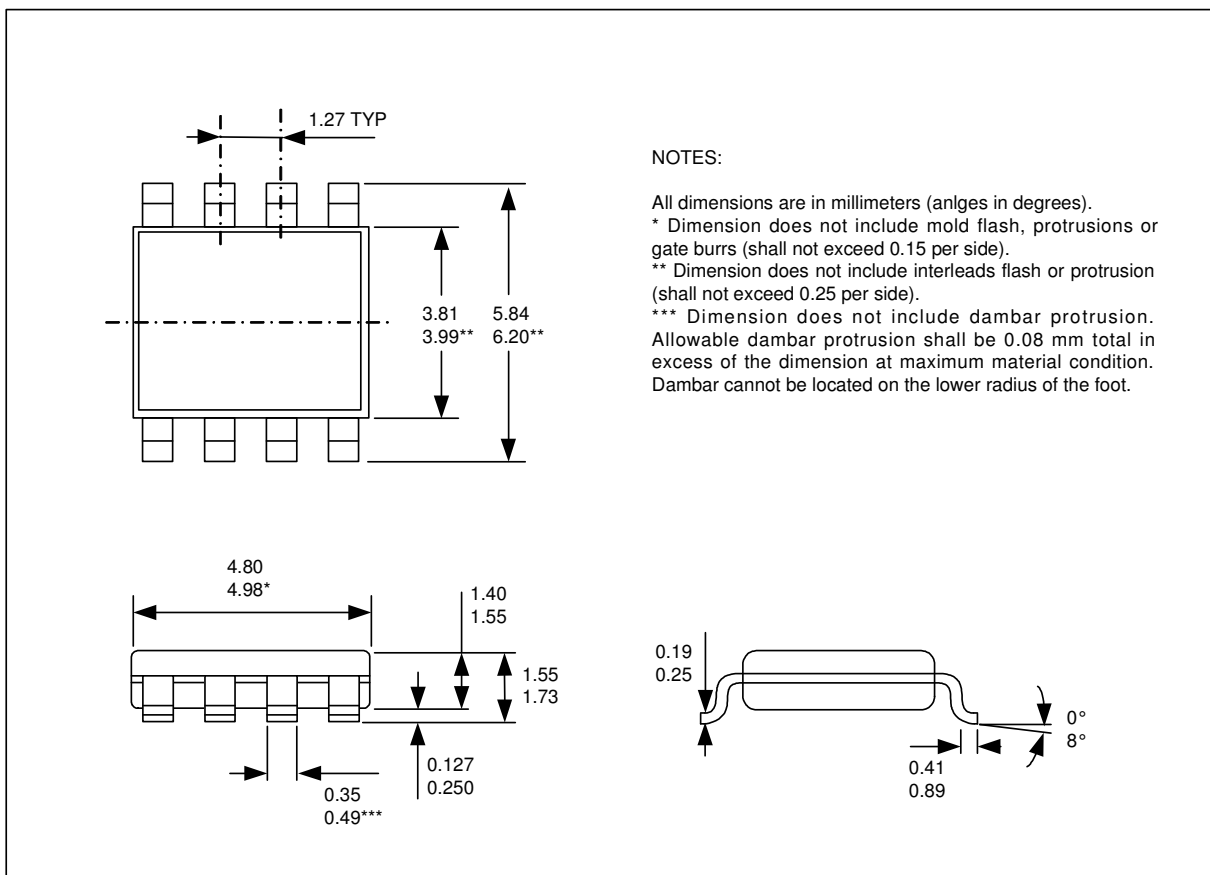

NOTES:

All dimensions are in millimeters (angles in degrees).
 * Dimension does not include mold flash, protrusions or gate burrs (shall not exceed 0.15 per side).
 ** Dimension does not include interleads flash or protrusion (shall not exceed 0.25 per side).
 *** Dimension does not include dambar protrusion. Allowable dambar protrusion shall be 0.08 mm total in excess of the dimension at maximum material condition. Dambar cannot be located on the lower radius of the foot.

11.2 Pinout and Marking

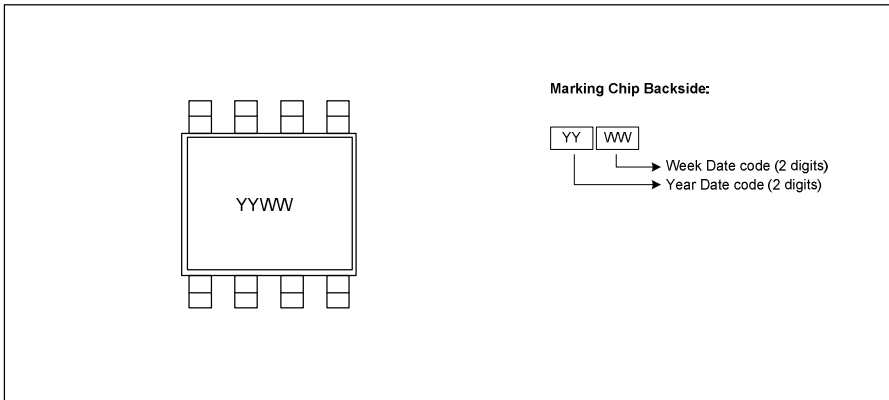
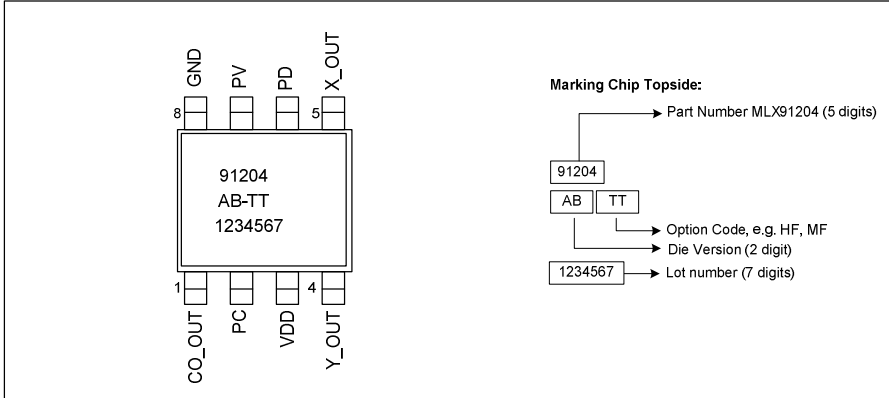

11.3 Hall Plate Positioning

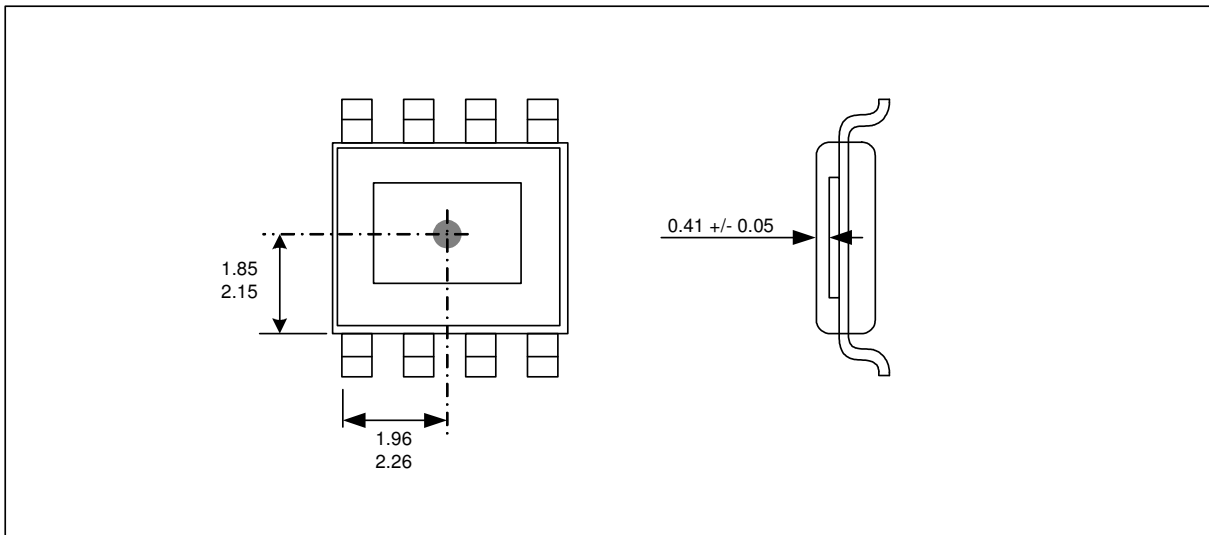



MLX91204

360 Degrees Hi-Speed Rotary Position Sensor (Sine/Cosine)

12 Disclaimer

Devices sold by Melexis are covered by the warranty and patent indemnification provisions appearing in its Term of Sale. Melexis makes no warranty, express, statutory, implied, or by description regarding the information set forth herein or regarding the freedom of the described devices from patent infringement. Melexis reserves the right to change specifications and prices at any time and without notice. Therefore, prior to designing this product into a system, it is necessary to check with Melexis for current information. This product is intended for use in normal commercial applications. Applications requiring extended temperature range, unusual environmental requirements, or high reliability applications, such as military, medical life-support or life-sustaining equipment are specifically not recommended without additional processing by Melexis for each application.

The information furnished by Melexis is believed to be correct and accurate. However, Melexis shall not be liable to recipient or any third party for any damages, including but not limited to personal injury, property damage, loss of profits, loss of use, interrupt of business or indirect, special incidental or consequential damages, of any kind, in connection with or arising out of the furnishing, performance or use of the technical data herein. No obligation or liability to recipient or any third party shall arise or flow out of Melexis' rendering of technical or other services.

© 2012 Melexis NV. All rights reserved.

For the latest version of this document, go to our website at
www.melexis.com

Or for additional information contact Melexis Direct:

Europe, Africa, Asia:
Phone: +32 1367 0495
E-mail: sales_europe@melexis.com

America:
Phone: +1 248 306 5400
E-mail: sales_usa@melexis.com

ISO/TS 16949 and ISO14001 Certified