



Intelligent Infrared CO2 Module (Model: MH-Z19B)

User's Manual

(Version: 1.0)

Valid from: 2016.01.21

Zhengzhou Winsen Electronics Technology Co., Ltd

ISO9001 certificated company

Statement

This manual's copyright belongs to Zhengzhou Winsen Electronics Technology Co., LTD. Without the written permission, any part of this manual shall not be copied, translated, stored in database or retrieval system, also can't spread through electronic, copying, record ways.

Thanks for purchasing our product. In order to let customers use it better and reduce the faults caused by misuse, please read the manual carefully and operate it correctly in accordance with the instructions. If users disobey the terms or remove, disassemble, change the components inside of the sensor, we shall not be responsible for the loss.

The specific such as color, appearance, sizes &etc., please in kind prevail.

We are devoting ourselves to products development and technical innovation, so we reserve the right to improve the products without notice. Please confirm it is the valid version before using this manual. At the same time, users' comments on optimized using way are welcome.

Please keep the manual properly, in order to get help if you have questions during the usage in the future.

Zhengzhou Winsen Electronics Technology CO., LTD.

MH-Z19B NDIR CO2 Module

1. Profile

MH-Z19B NDIR infrared gas module is a common type, small size sensor, using non-dispersive infrared (NDIR) principle to detect the existence of CO₂ in the air, with good selectivity, non-oxygen dependent and long life. Built-in temperature compensation; and it has UART output and PWM output. It is developed by the tight integration of mature infrared absorbing gas detection technology, precision optical circuit design and superior circuit design.

2. Applications

MH-Z19B NDIR infrared gas module is widely used in

- * HVAC refrigeration
- * Indoor air quality monitoring.
- * Smart home appliances
- * School
- * Air cleaner

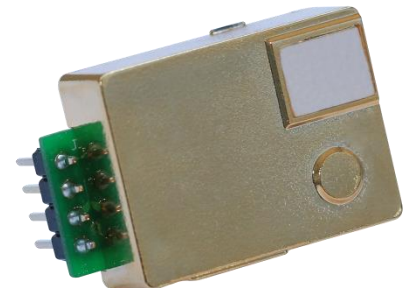

3. Main Functions and Features

High sensitivity, high resolution

Low power consumption

Output modes: UART and PWM wave

Temperature compensation, excellent linear output

Good stability

Long lifespan

Anti-water vapor interference

No poisoning

4. Technical Parameters and Structure

Product Model	MH-Z19B
Target Gas	CO ₂
Working voltage	4.5 ~ 5.5 V DC
Average current	< 60mA (@5V)
Peak current	150mA (@5V)
Interface level	3.3 V(Compatible with 5V)
Measuring range	refer to Table 2
Output signal	UART(TTL interface level 3.3V)
	PWM
	DAC(default 0.4-2V)
Preheat time	3 min
Response Time	T ₉₀ < 120 s
Working temperature	0 ~ 50 °C
Working humidity	0 ~ 90% RH (No condensation)
Dimension	33 mm×20 mm×9 mm (L×W×H)
Weight	5 g
Lifespan	> 5 years

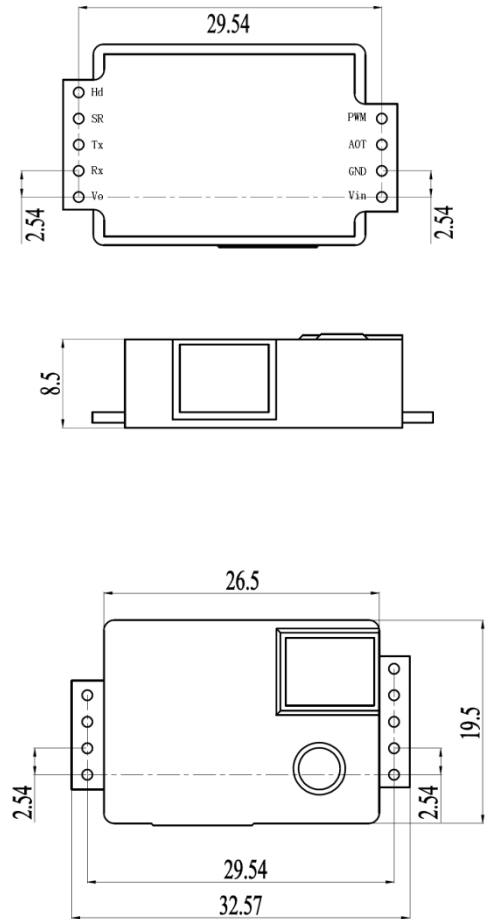

Table 1 Main Technical Parameters

Figure 1 Structure

Target Gas	Formula	Measuring Range	Accuracy	Remark
Carbon Dioxide (CO ₂)	CO ₂	0~2000 ppm	± (50ppm+3% reading value)	Temperature compensation
		0~5000 ppm		Temperature compensation

Table 2 Measuring Range and Accuracy

5. Product Dimensions

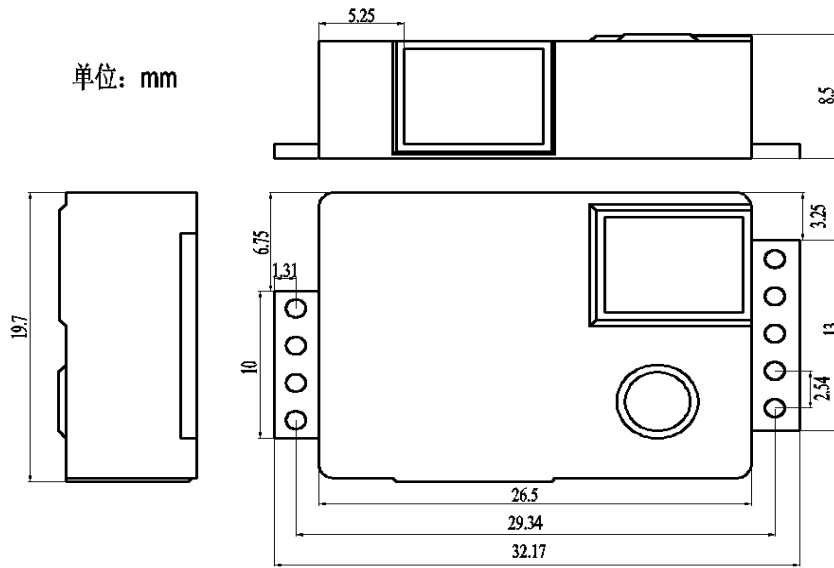

6. Pins

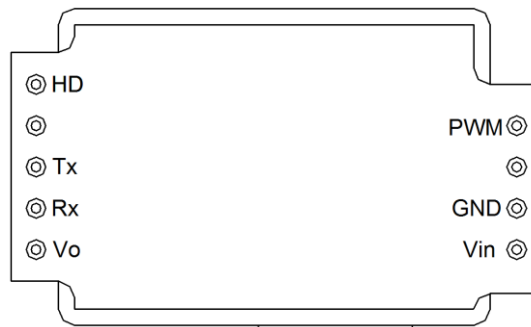

Pin	Definition
Vin	Vin
GND	GND
Vo	Analog output(0.4~2 V)or (0~2.5V)
PWM	PWM
HD	HD(zero calibration, low level lasting for over 7s under low level is effective)
Rx	UART(RXD)TTL Level data input
Tx	UART(TXD)TTL Level data output

7. Output

PWM output	
Take 0~2000ppm for e.g	
CO ₂ range	0~2000ppm
cycle	1004ms±5%
Cycle start high level output	2ms(theoretical value)
The middle cycle	1000ms±5%
cycle end low level output	2ms(theoretical value)
CO ₂ level: $C_{ppm} = 2000 \times (T_H - 2ms) / (T_H + T_L - 4ms)$	
C _{ppm} : CO ₂ level which calculated by PWM output	
T _H : high level output time during cycle	
T _L low level output time during cycle	

UART OUTPUT

Hardware

Connect sensor pin Vin-GND-RXD-TXD with 5V-GND-TXD-RXD. (Customers must use TTL level. RS232 level needs **conversion**) .

Software

General Settings

Baud Rate	9600
Data Bits	8
Stop Bits:	1
Parity(check bits):	0(NO)

Commands	
0x86	Read CO ₂ concentration
0x87	Calibrate Zero Point (ZERO)
0x88	Calibrate Span Point (SPAN)
0x79	ON/OFF Auto Calibration
0x99	Detection range setting

0x86- Read CO ₂ concentration								
Request								
Byte0	Byte1	Byte2	Byte3	Byte4	Byte5	Byte6	Byte7	Byte8
Start Byte	Sensor #	Command	-	-	-	-	-	Checksum
0xFF	0x01	0x86	0x00	0x00	0x00	0x00	0x00	0x79
Response								
Byte0	Byte1	Byte2	Byte3	Byte4	Byte5	Byte6	Byte7	Byte8
Start Byte	Sensor #	Concentration (High Byte)	Concentration (Low Byte)	-	-	-	-	Checksum
0xFF	0x86	HIGH	LOW	-	-	-	-	Checksum
CO₂ concentration = HIGH * 256 + LOW								

0x87-ZERO POINT CALIBRATION								
Request								
Byte0	Byte1	Byte2	Byte3	Byte4	Byte5	Byte6	Byte7	Byte8
Start Byte	Sensor #	Command	-	-	-	-	-	Checksum
0xFF	0x01	0x87	0x00	0x00	0x00	0x00	0x00	校验和
NO RESPONSE								
NOTE: ZERO POINT is 400PPM, PLS MAKE SURE THE SENSOR HAD BEEN WORKED UNDER 400PPM FOR OVER 20MINUTES								

0x88- SPAN POINT CALIBRATION								
Request								
Byte0	Byte1	Byte2	Byte3	Byte4	Byte5	Byte6	Byte7	Byte8
Start Byte	Sensor #	Command	Span (High Byte)	Span (low Byte)	-	-	-	Checksum
0xFF	0x01	0x88	HIGH	LOW	0x00	0x00	0x00	Checksum

No response

E.g.: SPAN is 2000ppm, HIGH = 2000 / 256; LOW = 2000 % 256

Note: Pls do ZERO calibration before span calibration

Please make sure the sensor worked under a certain level co2 for over 20 minutes.

Suggest using 2000ppm as span, at least 1000ppm

0x79- ABC logic on/off								
Request								
Byte0	Byte1	Byte2	Byte3	Byte4	Byte5	Byte6	Byte7	Byte8
Start Byte	Sensor #	Command	-	-	-	-	-	Checksum
0xFF	0x01	0x79	0xA0/0x00	0x00	0x00	0x00	0x00	Checksum

No response

Note: Byte3 is **0xA0,ABC on**; Byte3 is **0x00, ABC off**

All Winsen sensor with ABC logic on before delivery if no special request.

0x99- Sensor detection range setting								
Request								
Byte0	Byte1	Byte2	Byte3	Byte4	Byte5	Byte6	Byte7	Byte8
Start Byte	Sensor #	Command	Detect range (high Byte)	Detect range (low Byte)	-	-	-	Checksum
0xFF	0x01	0x99	HIGH	LOW	0x00	0x00	0x00	Checksum

No response

Note: Detection range is 2000 or 5000ppm

Detection range high byte=detection range/256

Detection range low byte=detection range/% 256

Checksum								
Checksum = (NOT (Byte1+Byte2+Byte3+Byte4+Byte5+Byte6+Byte7))+1								
Byte0	Byte1	Byte2	Byte3	Byte4	Byte5	Byte6	Byte7	Byte8
Start Byte	Sensor #	Command	-	-	-	-	-	Checksum
0xFF	0x01	0x86	0x00	0x00	0x00	0x00	0x00	Checksum

Calculating Checksum

:

- 0x01 + 0x86 + 0x00 + 0x00 + 0x00 + 0x00 + 0x00 = 0x87
- NOT: 0xFF - 0x87 = 0x78

3、NOT+1: 0x78 + 0x01 = 0x79

C language

```
char getChecksum(char *packet)
{
    char i, checksum;
    for( i = 1; i < 8; i++)
    {
        checksum += packet[i];
    }
    checksum = 0xff - checksum;
    checksum += 1;
    return checksum;
}
```

8.ZERO point calibration

Three methods:

A: Manual calibration

Sensor HD pin with low level(0V) and lasting for over 7s(under 400ppm for at least 20 minutes)

B:Command calibration(see above)

C: ABC logic function

Automatic Baseline Correction (ABC logic function)

ABC logic function refers to that sensor itself do zero point judgment and automatic calibration procedure intelligently after a continuous operation period. The automatic calibration cycle is every 24 hours after powered on. The zero point of automatic calibration is 400ppm. From July 2015, the default setting is with built-in automatic calibration function if no special request.

This function is usually suitable for indoor air quality monitor such as offices, schools and homes, not suitable for greenhouse, farm and refrigeratory where this function should be off. Please do zero calibration timely, such as manual or commend calibration.

9. Notes

9.1 Please avoid the pressure of its gilded plastic chamber from any direction, during welding, installation, and use.

9.2 When placed in small space, the space should be well ventilated, especially for diffusion window.

9.3 The sensor should be away from heat, and avoid direct sunlight or other heat radiation.

9.4 Do not use the sensor in the high dusty environment for long time.

9.5 To ensure the normal work, the power supply must be among 4.5V~5.5V DC rang, the power current must be not less than 150mA. Out of this range, it will result in the failure of the sensor. (The concentration output is low, or the sensor can not work normally.)

8.6 During the zero point calibration procedure by manual, the sensor must work in stable gas environment (400ppm) for over 20 minutes.

Connect the HD pin to low level (0V) for over 7 seconds.

Zhengzhou Winsen Electronics Technology Co., Ltd

Add: No.299, Jinsuo Road, National Hi-Tech Zone,
Zhengzhou 450001 China

Tel: +86-371-67169097/67169670

Fax: +86-371-60932988

E-mail: sales@winsensor.com

Website: www.winsen-sensor.com