

## 300mA High PSRR LDO Regulators

### Features

- Low, 90 $\mu$ A No-Load Supply Current
- Guaranteed 300mA Output Current
- Dropout Voltage is 200mV @ 150mA Load
- PSRR=65dB @ 120Hz
- Over-Temperature Protection and Short-Circuit Protection
- Two Modes of Operation ----  
 Fixed Mode: 1.50V~5.00V  
 Adjustable Mode: from 1.25V to 5.50V
- Max. Supply Current in Shutdown Mode < 1 $\mu$ A
- Low Output Noise at 238 $\mu$ V<sub>RMS</sub>
- Stable with low cost ceramic capacitors

### Applications

- Notebook Computers
- Cellular Phones
- PDAs
- Digital still Camera and Video Recorders
- Hand-Held Devices
- Audio Codec

### General Description

The G923 is a low supply current, high PSRR, and low dropout linear regulator that comes in a space saving SOT-23-5 package. The supply current at no-load is 90 $\mu$ A. In the shutdown mode, the maximum supply current is less than 1 $\mu$ A. Operating voltage range of the G923 is from 2.50V to 5.50V. The over-current protection limit is set at 550mA typical. An over-temperature protection circuit is built-in in the G923 to prevent thermal overload. These power saving features make the G923 ideal for use in the battery-powered applications such as notebook computers, cellular phones, and PDA's.

The G923 has two modes of operation. When the SET pin is connected to ground, its output is a pre-set value: 1.50V~5.00V. There is no external component needed to decide the output voltage. When an output other than the preset value is needed, two external resistors should be used as a voltage divider. The output voltage is then decided by the resistor ratio. The G923 comes in a space saving SOT-23-5 package.

### Pin Configuration

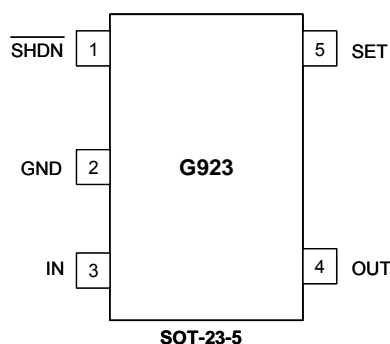

### Typical Application Circuit

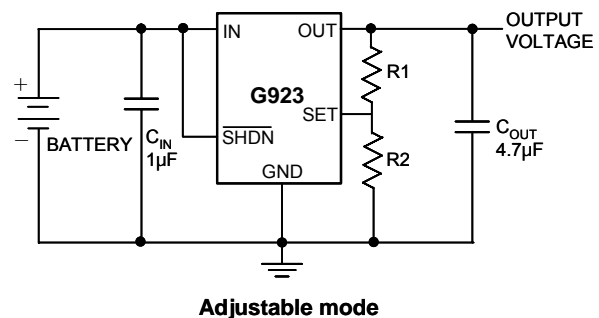
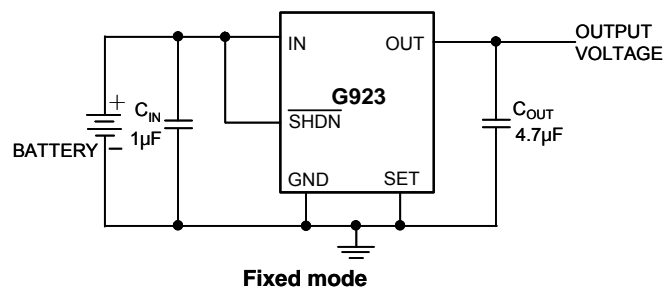

**Ordering Information**

ORDER NUMBER	ORDER NUMBER (Pb free)	MARKING	VOLTAGE	TEMP. RANGE	PACKAGE
G923-330T1U	G923-330T1Uf	92AUx	3.30V	-40°C~ +85°C	SOT-23-5

For other output voltage, please contact us at sales@gmt.com.tw

Note: T1: SOT-23-5

U: Tape & Reel

**Selector Guide**

ORDER NUMBER	ORDER NUMBER (Pb free)	OUTPUT VOLTAGE (V)	MARKING
G923-150T1U	G923-150T1Uf	1.50	92AAx
G923-160T1U	G923-160T1Uf	1.60	92ABx
G923-170T1U	G923-170T1Uf	1.70	92ACx
G923-180T1U	G923-180T1Uf	1.80	92ADx
G923-190T1U	G923-190T1Uf	1.90	92AEx
G923-200T1U	G923-200T1Uf	2.00	92AFx
G923-210T1U	G923-210T1Uf	2.10	92AGx
G923-220T1U	G923-220T1Uf	2.20	92AHx
G923-230T1U	G923-230T1Uf	2.30	92Aix
G923-240T1U	G923-240T1Uf	2.40	92AJx
G923-250T1U	G923-250T1Uf	2.50	92AKx
G923-260T1U	G923-260T1Uf	2.60	92ALx
G923-270T1U	G923-270T1Uf	2.70	92AMx
G923-280T1U	G923-280T1Uf	2.80	92ANx
G923-285T1U	G923-285T1Uf	2.85	92AOx
G923-290T1U	G923-290T1Uf	2.90	92APx
G923-300T1U	G923-300T1Uf	3.00	92AQx
G923-310T1U	G923-310T1Uf	3.10	92ARx
G923-315T1U	G923-315T1Uf	3.15	92ASx
G923-320T1U	G923-320T1Uf	3.20	92ATx
G923-330T1U	G923-330T1Uf	3.30	92AUx
G923-340T1U	G923-340T1Uf	3.40	92AVx
G923-350T1U	G923-350T1Uf	3.50	92AWx
G923-360T1U	G923-360T1Uf	3.60	92AXx
G923-370T1U	G923-370T1Uf	3.70	92AYx
G923-380T1U	G923-380T1Uf	3.80	92AZx
G923-390T1U	G923-390T1Uf	3.90	92BAx
G923-400T1U	G923-400T1Uf	4.00	92BBx
G923-410T1U	G923-410T1Uf	4.10	92BCx
G923-420T1U	G923-420T1Uf	4.20	92BDx
G923-430T1U	G923-430T1Uf	4.30	92BEx
G923-440T1U	G923-440T1Uf	4.40	92BFx
G923-450T1U	G923-450T1Uf	4.50	92BGx
G923-460T1U	G923-460T1Uf	4.60	92BHx
G923-470T1U	G923-470T1Uf	4.70	92Bix
G923-475T1U	G923-475T1Uf	4.75	92BJx
G923-480T1U	G923-480T1Uf	4.80	92BKx
G923-490T1U	G923-490T1Uf	4.90	92BLx
G923-500T1U	G923-500T1Uf	5.00	92BMx

**Absolute Maximum Ratings**

$V_{IN}$ to GND	-0.3V to 7V
Output Short-Circuit Duration	Infinite
SET to GND	-0.3V to 7V
SHDN to GND	-0.3V to 7V
SHDN to IN	-7V to 0.3V
OUT to GND	-0.3V to ( $V_{IN} + 0.3V$ )

Continuous Power Dissipation ( $T_A = 25^\circ\text{C}$ )	
SOT-23-5	520mW
Operating Temperature Range	$-40^\circ\text{C}$ to $85^\circ\text{C}$
Junction Temperature	$150^\circ\text{C}$
Thermal Resistance Junction to Ambient, ( $\theta_{JA}$ )	
SOT-23-5	$240^\circ\text{C}/\text{Watt}^{(1)}$
Storage Temperature Range	$-65^\circ\text{C}$ to $160^\circ\text{C}$
Reflow Temperature (soldering, 10sec)	$260^\circ\text{C}$

Note <sup>(1)</sup>: See Recommended Minimum Footprint (P.8 Figure 3)

Stresses beyond those listed under "Absolute Maximum Ratings" may cause permanent damage to the device. These are stress ratings only, and functional operation of the device at these or any other conditions beyond those indicated in the operational sections of the specifications is not implied. Exposure to absolute maximum rating conditions for extended periods may affect device reliability.

**Electrical Characteristics**

( $V_{IN} = +3.6V$ ,  $V_{SHDN} = V_{IN}$ ,  $T_A = T_J = +25^\circ\text{C}$ , unless otherwise noted.) (Note 1)

PARAMETER	SYMBOL	CONDITION	MIN	TYP	MAX	UNIT	
Input Voltage (Note 2)	$V_{IN}$		2.5	---	5.5	V	
Output Voltage Accuracy	$V_{OUT}$	Variation from specified $V_{OUT}$ , $I_{OUT} = 1\text{mA}$	-2	---	2	%	
Adjustable Output Voltage Range (Note 3)	$V_{OUT}$		$V_{SET}$	---	5.5	V	
Maximum Output Current			300	---	---	mA	
Current Limit (Note 4)	$I_{LIM}$		400	550	---	mA	
Short Circuit Current	$I_{SC}$		---	280	---	mA	
Ground Pin Current	$I_Q$		---	90	120	$\mu\text{A}$	
Dropout Voltage (Note 5)	$V_{DROP}$	$I_{OUT} = 150\text{mA}$	---	200	---	mV	
		$I_{OUT} = 300\text{mA}$ , $V_{OUT} = 2.7V$	---	500	700		
		$I_{OUT} = 300\text{mA}$ , $V_{OUT} > 3.0V$	---	400	500		
Line Regulation	$\Delta V_{LNR}$	SET=GND, $V_{IN} = V_{(STD)} + 0.1V$ to $5.5V$ , $I_{OUT} = 10\text{mA}$	---	0.06	0.12	%/V	
Load Regulation	$\Delta V_{LDR}$	$I_{OUT} = 10\text{mA}$ to $300\text{mA}$	---	0.1	1	%	
Ripple Rejection	PSRR	$F = 100\text{Hz}$ , $0.45V_{P-P}$ , $I_{OUT} = 10\text{mA}$	---	65	---	dB	
Output Noise	Noise	$F \leq 100\text{kHz}$ , $I_o = 0A$	---	136	---	$\mu\text{V}$ (RMS)	
		$F \leq 100\text{kHz}$ , $I_o = 150\text{mA}$	---	238	---		
		$F \leq 100\text{kHz}$ , $I_o = 300\text{mA}$	---	253	---		
<b>SHUTDOWN</b>							
SHDN Input Threshold	$V_{IH}$	Regulator enabled	1.5	---	---	V	
	$V_{IL}$	Regulator shutdown	---	---	0.4		
SHDN Input Bias Current	$I_{SHDN}$	$V_{SHDN} = V_{IN}$ , $T_A = +25^\circ\text{C}$	---	0.003	0.1	$\mu\text{A}$	
Shutdown Supply Current	$I_{QSHDN}$	$V_{OUT} = 0V$ , $T_A = +25^\circ\text{C}$	---	0.2	1	$\mu\text{A}$	
<b>SET INPUT</b>							
SET Reference Voltage (Note 3)	$V_{SET}$	$V_{IN} = 2.5V$ to $5.5V$ , $I_{OUT} = 1\text{mA}$	$T_A = +25^\circ\text{C}$	1.225	1.25	1.275	V
			$T_A = T_{MIN}$ to $T_{MAX}$	---	1.25	---	
SET Input Leakage Current (Note 3)	$I_{SET}$	$V_{SET} = 1.3V$ , $T_A = +25^\circ\text{C}$	---	5	30	nA	
<b>THERMAL PROTECTION</b>							
Thermal Shutdown Temperature	$T_{SHDN}$		---	145	---	$^\circ\text{C}$	
Thermal Shutdown Hysteresis	$\Delta T_{SHDN}$		---	25	---	$^\circ\text{C}$	

Note 1: Limits is 100% production tested at  $T_A = +25^\circ\text{C}$ . Low duty pulse techniques are used during test to maintain junction temperature as close to ambient as possible.

Note 2: Guaranteed by line regulation test.

Note 3: Adjustable mode only.

Note 4: Not tested. For design purposes, the current limit should be considered 400mA minimum to 650mA maximum.

Note 5: The dropout voltage is defined as ( $V_{IN} - V_{OUT}$ ) when  $V_{OUT}$  is 100mV below the target value of  $V_{OUT}$ . The performance of every G923 part, see "Typical Performance Characteristics".

**Typical Performance Characteristics**

( $V_{IN}=5V$ ,  $V_{OUT}=3.3V$ ,  $C_{IN}=1\mu F$ ,  $C_{OUT}=1\mu F$ ,  $T_A=25^\circ C$ , unless otherwise noted.)

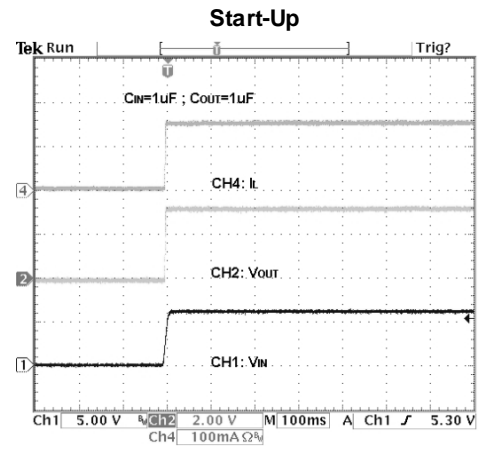
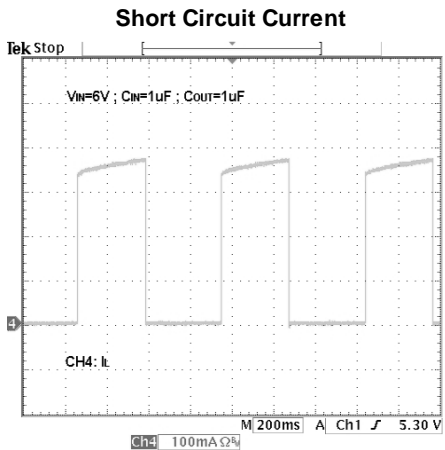
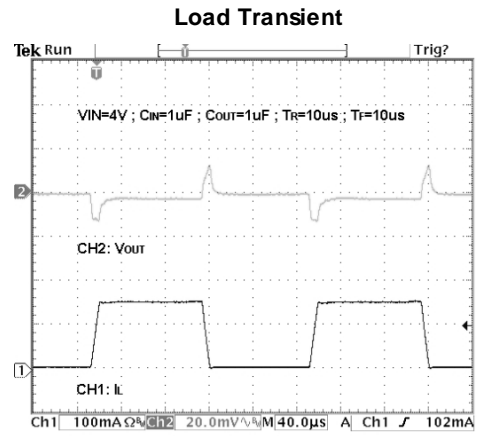
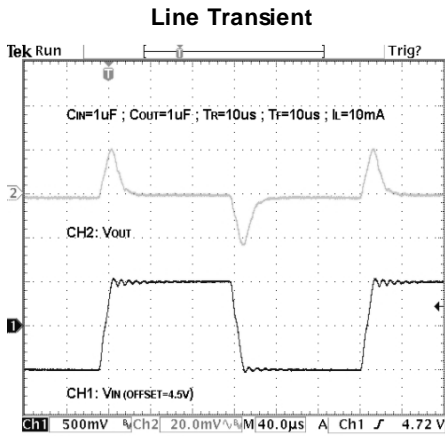

**Overcurrent Protection Characteristics**

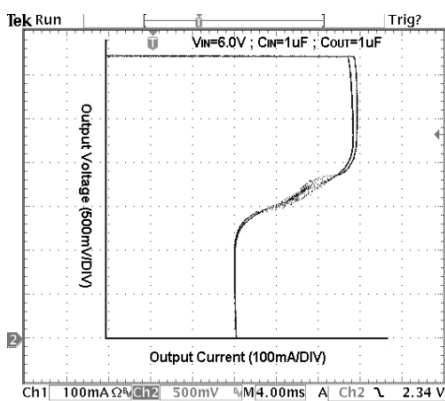

**Ripple Rejection**

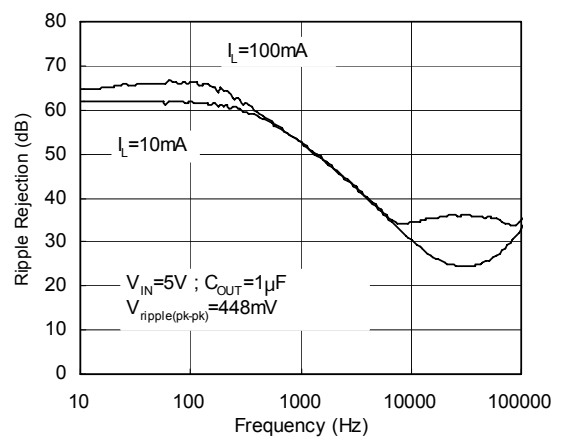

Typical Performance Characteristics (continued)

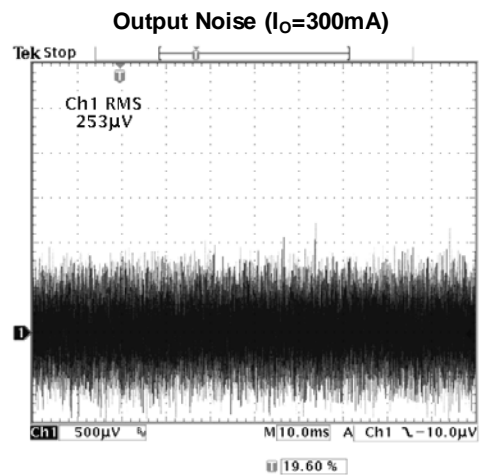
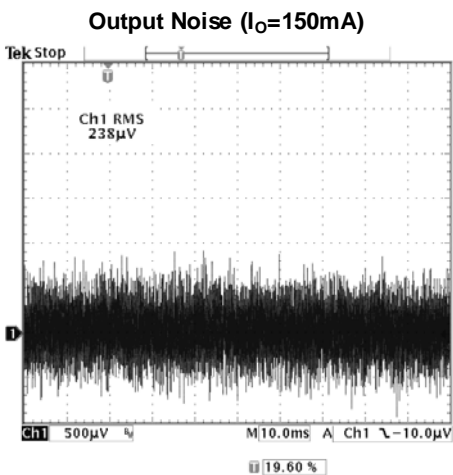
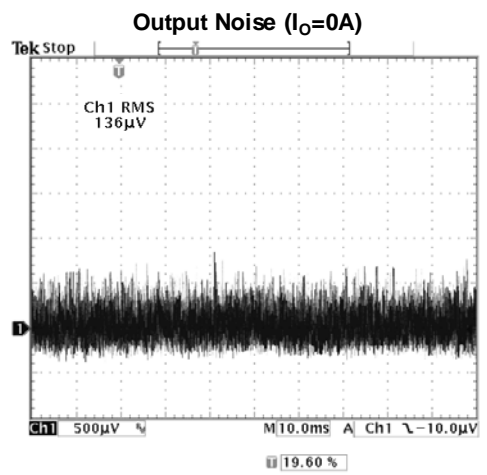
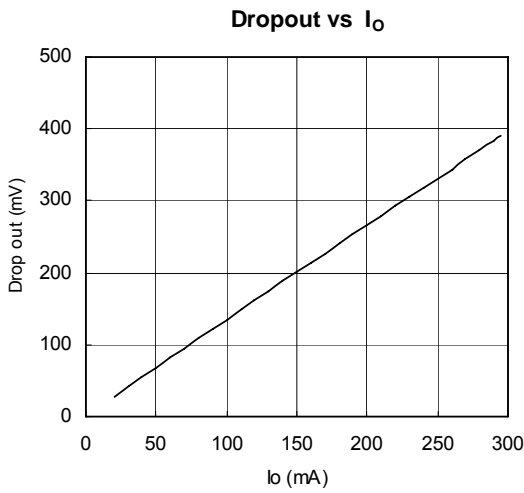
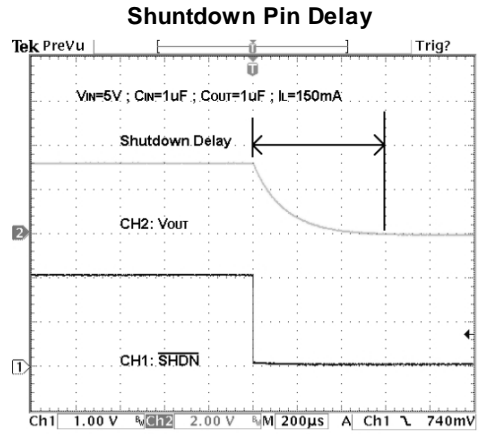
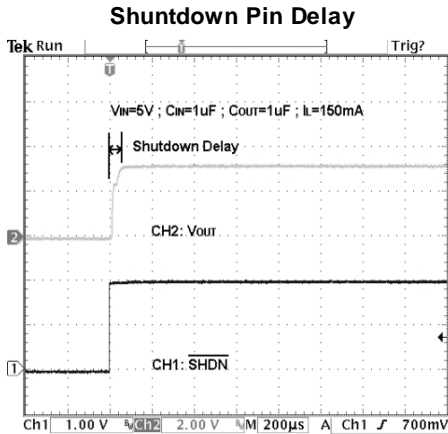

## Pin Description

PIN	NAME	FUNCTION
1	$\overline{\text{SHDN}}$	Active-Low Shutdown Input. A logic low reduces the supply current to less than 1 $\mu$ A. Connect to IN for normal operation.
2	GND	Ground. This pin also functions as a heatsink. Solder to large pads or the circuit board ground plane to maximize thermal dissipation.
3	IN	Regulator Input. Supply voltage can range from +2.5V to +5.5V. Bypass with 1 $\mu$ F to GND
4	OUT	Regulator Output. Fixed or adjustable from 1.25V to +5.5V. Sources up to 300mA. Bypass with a 4.7 $\mu$ F, < 0.2 $\Omega$ typical ESR capacitor to GND.
5	SET	Feedback Input for Setting the Output Voltage. Connect to GND to set the output voltage to the preset output voltage. Connect to an external resistor divider for adjustable-output operation.

## Detailed Description

The block diagram of the G923 is shown in Figure 1. It consists of an error amplifier, 1.25V bandgap reference, PMOS output transistor, internal feedback voltage divider, mode comparator, shutdown logic, over current protection circuit, and over temperature protection circuit.

The mode comparator compares the SET pin voltage with an internal 350mV reference. If the SET pin voltage is less than 350mV, the internal feedback voltage divider's central tap is connected to the non-inverting input of the error amplifier. The error amplifier compares non-inverting input with the 1.25V bandgap reference. If the feedback voltage is higher than 1.25V, the error amplifier's output becomes higher so that the PMOS output transistor has a smaller gate-to-source voltage ( $V_{GS}$ ). This reduces the current carrying capability of the PMOS output transistor, as a result the output voltage decreases until the feedback voltage is equal to 1.25V. Similarly, when the feedback voltage is less than 1.25V, the error amplifier causes the output PMOS to source more current to pull the feedback

voltage up to 1.25V. Thus, through this feedback action, the error amplifier, output PMOS, and the voltage dividers effectively form a unity-gain amplifier with the feedback voltage force to be the same as the 1.25V bandgap reference. The output voltage,  $V_{OUT}$ , is then given by the following equation:

$$V_{OUT} = 1.25 (1 + R1/R2). \quad (1)$$

Alternatively, the relationship between R1 and R2 is given by:

$$R1 = R2 (V_{OUT} / 1.25 - 1). \quad (2)$$

For the reasons of reducing power dissipation and loop stability, R2 is chosen to be 100K $\Omega$ . For G923-330, R1 is 164K, and the pre-set VOUT is 3.30V.

When external voltage divider is used, as shown in Figure 2, the SET pin voltage will be larger than 350mV. The non-inverting input of the amplifier will be connected to the external voltage divider. However, the operation of the feedback loop is the same, so that the conditions of Equations 1 and 2 are still true. The output voltage is still given by Equation 1.

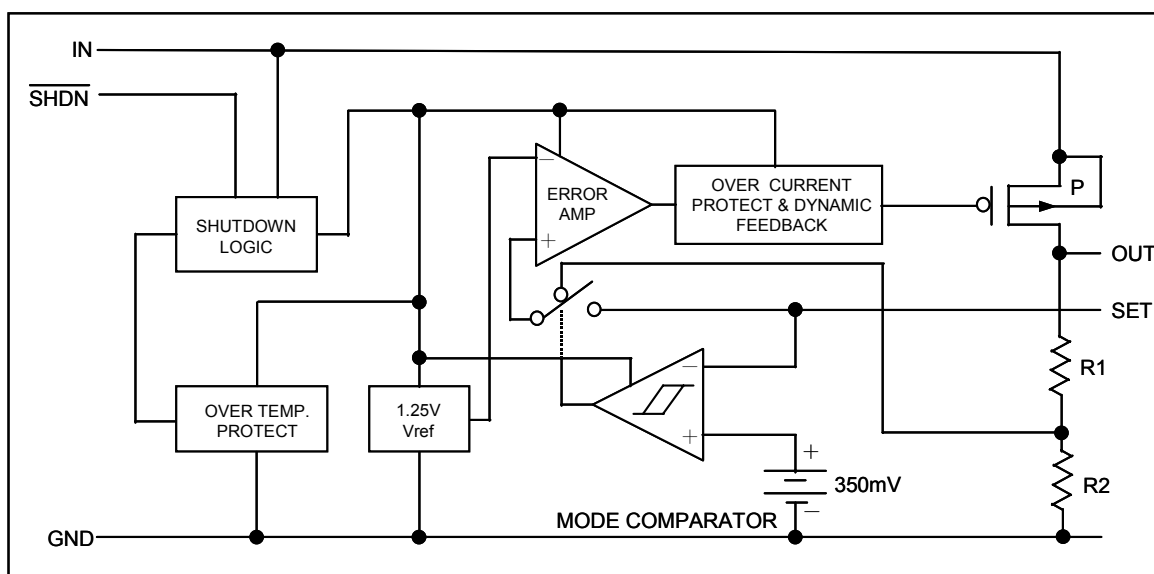
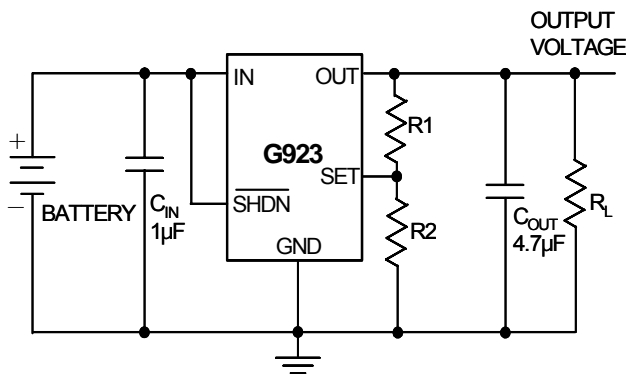

Figure 1. Functional Diagram





**Figure 2. Adjustable Output Using External Feedback Resistors**

### Over Current Protection

The G923 uses a current sense-resistor to monitor the output current. A portion of the PMOS output transistor's current is mirrored to a resistor such that the voltage across this resistor is proportional to the output current. Once the output current exceeds limit threshold, G923 would be protected with a limited output current. Further more, when the output is short to ground, the output current would be folded-back to a less limit.

### Over Temperature Protection

To prevent abnormal temperature from occurring, the G923 has a built-in temperature monitoring circuit. When it detects the temperature is above 145°C, the output transistor is turned off. When the IC is cooled down to below 120°C, the output is turned on again. In this way, the G923 will be protected against abnormal junction temperature during operation.

### Shutdown Mode

When the  $\overline{\text{SHDN}}$  pin is connected a logic low voltage, the G923 enters shutdown mode. All the analog circuits are turned off completely, which reduces the current consumption to only the leakage current. The G923 output pass transistor would get into high impedance level. There is an internal discharge path to help to shorten discharge delay time.

### Operating Region and Power Dissipation

Since the G923 is a linear regulator, its power dissipation is always given by  $P = I_{\text{OUT}} (V_{\text{IN}} - V_{\text{OUT}})$ . The maximum power dissipation is given by:

$$P_{\text{D(MAX)}} = (T_{\text{J}} - T_{\text{A}}) / \theta_{\text{JA}} = (150^{\circ}\text{C} - 25^{\circ}\text{C}) / 240^{\circ}\text{C/W} = 520\text{mW}$$

Where  $(T_{\text{J}} - T_{\text{A}})$  is the temperature difference the G923 die and the ambient air,  $\theta_{\text{JA}}$ , is the thermal resistance of the chosen package to the ambient air. For surface

mount device, heat sinking is accomplished by using the heat spreading capabilities of the PC board and its copper traces. In the case of a SOT-23-5 package, the thermal resistance is typically 240°C/Watt. (See Recommended Minimum Footprint) [Figure 3] Refer to Figure 4 is the G923 valid operating region (Safe Operating Area) & refer to Figure 5 is maximum power dissipation of SOT-23-5.

The die attachment area of the G923's lead frame is connected to pin 2, which is the GND pin. Therefore, the GND pin of G923 can carry away the heat of the G923 die very effectively. To improve the maximum power providing capability, connect the GND pin to ground using a large ground plane near the GND pin.

## Applications Information

### Capacitor Selection and Regulator Stability

Normally, use a 1µF capacitor on the input and a 4.7µF capacitor on the output of the G923. Larger input capacitor values and lower ESR provide better supply-noise rejection and transient response. A higher-value input capacitor (10µF) may be necessary if large, fast transients are anticipated and the device is located several inches from the power source.

### Power-Supply Rejection and Operation from Sources Other than Batteries

The G923 is designed to deliver low dropout voltages and low quiescent currents in battery powered systems. Power-supply rejection is 65dB at low frequencies. As the frequency increases above 20kHz, the output capacitor is the major contributor to the rejection of power-supply noise.

When operating from sources other than batteries, improve supply-noise rejection and transient response by increasing the values of the input and output capacitors, and using passive filtering techniques.

### Load Transient Considerations

The G923 load-transient response graphs show two components of the output response: a DC shift of the output voltage due to the different load currents, and the transient response. Typical overshoot for step changes in the load current from 10mA to 300mA is 8mV. Increasing the output capacitor's value and decreasing its ESR attenuates transient spikes.

### Input-Output (Dropout) Voltage

A regulator's minimum input-output voltage differential (or dropout voltage) determines the lowest usable supply voltage. In battery-powered systems, this will determine the useful end-of-life battery voltage. Because the G923 use a P-channel MOSFET pass transistor, their dropout voltage is a function of  $R_{\text{DS(ON)}}$  multiplied by the load current.

**Layout Guide**

An input capacitance of  $\cong 1\mu\text{F}$  is required between the G923 input pin and ground (the amount of the capacitance may be increased without limit), This capacitor must be located a distance of not more than 1cm from the input and return to a clean analog ground.

Input capacitor can filter out the input voltage spike caused by the surge current due to the inductive effect of the package pin and the printed circuit board's routing wire. Otherwise, the actual voltage at the IN pin may exceed the absolute maximum rating.

The output capacitor also must be located a distance of not more than 1cm from output to a clean analog ground. Because it can filter out the output spike caused by the surge current due to the inductive effect of the package pin and the printed circuit board's routing pin and wire. Figure 6 is adjustable mode of G923 PCB layout. Figure 7 is a PCB layout of G923 fixed mode.

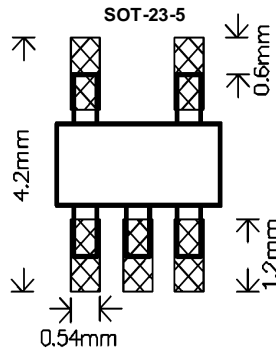

Figure 3. Recommended Minimum Footprint

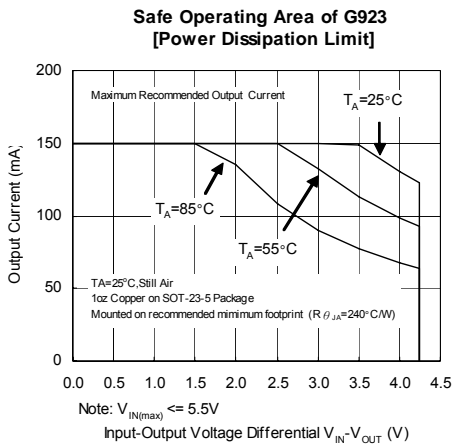

Figure 4. Safe Operating Area

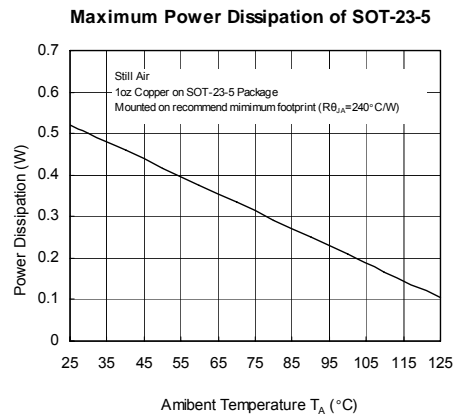
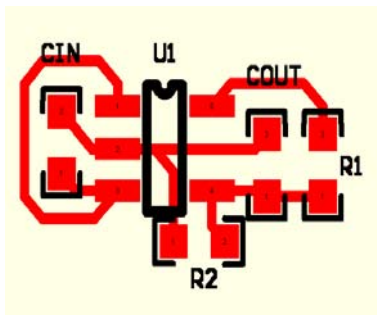
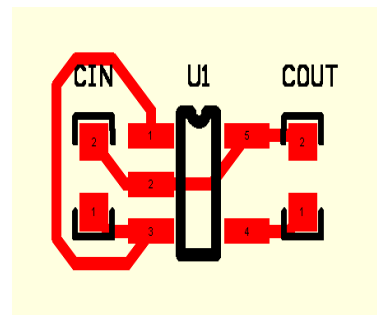

Figure 5. Power Dissipation vs. Temperature



\*Distance between pin & capacitor must no more than 1cm

Figure 6. Adjustable Mode



\*Distance between pin & capacitor must no more than 1cm

Figure 7. Fixed Mode



## Package Information

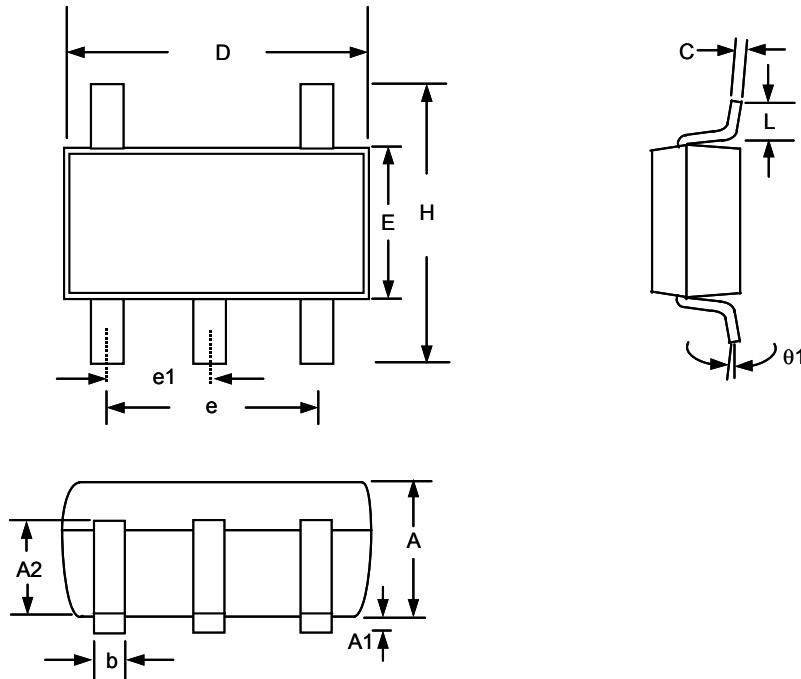

**Note:**

1. Package body sizes exclude mold flash protrusions or gate burrs
2. Tolerance  $\pm 0.1000$  mm (4mil) unless otherwise specified
3. Coplanarity: 0.1000mm
4. Dimension L is measured in gage plane

SYMBOL	DIMENSION IN MM			DIMENSION IN INCH		
	MIN.	NOM.	MAX.	MIN.	NOM.	MAX.
A	1.00	1.10	1.30	0.039	0.043	0.051
A1	0.00	----	0.10	0.000	----	0.004
A2	0.70	0.80	0.90	0.028	0.031	0.035
b	0.35	0.40	0.50	0.014	0.016	0.020
C	0.10	0.15	0.25	0.004	0.006	0.010
D	2.70	2.90	3.10	0.106	0.114	0.122
E	1.40	1.60	1.80	0.055	0.063	0.071
e	----	1.90(TYP)	----	----	0.075(TYP)	----
e1	----	0.95	----	----	0.037	----
H	2.60	2.80	3.00	0.102	0.110	0.118
L	0.37	----	----	0.015	----	----
$\theta 1$	1°	5°	9°	1°	5°	9°

## Taping Specification

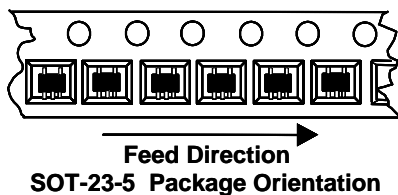

PACKAGE	Q'TY/REEL
SOT-23-5	3,000 ea

GMT Inc. does not assume any responsibility for use of any circuitry described, no circuit patent licenses are implied and GMT Inc. reserves the right at any time without notice to change said circuitry and specifications.