



# AS431L

## Low Voltage Precision Adjustable Shunt Regulator

### FEATURES

- **Tight Tolerance**..... **0.5% @ 10mA**
- **Wide Operating Range**..... **1mA to 100mA**
- **Low Extended Temperature Range**..... **0°C to 105°C**
- **Low Temperature Coefficient** ..... **30 ppm/°C**
- **Offered in TO-92, SOT-89, SOT-23-3 and SO-8**
- **Improved replacement in performance of AS431 & TL431**
- **Low Cost Solution**

### APPLICATIONS

- Battery Operating Equipment
- Adjustable Supplies
- Switching Power Supplies
- Error Amplifiers
- Single Supply Amplifier
- Monitors/ VCR/ TV
- Personal Computers

### PRODUCT DESCRIPTION

The AS431L is a 3-terminal Adjustable Shunt Voltage Regulator providing a highly accurate bandgap reference. AS431L acts as an open-loop error amplifier with a 2.5V temperature compensation reference. The AS431L thermal stability, wide operating current (100mA) and temperature range (0°C to 105°C) makes it suitable for all variety of applications that are looking for a low cost solution with high performance.

The output voltage may be adjusted to any value between  $V_{REF}$  and 20V with 2 external resistors. The AS431L is operating in full industrial temperature range of 0°C to 105°C. The AS431L is available in TO-92, SOT-89, SOT-23-3 and SO-8 packages.

### ORDERING INFORMATION

Part Number	Temperature Range	Package Type
AS431LXN	0°C to 105°C	TO-92
AS431LXM1	0°C to 105°C	SOT-89
AS431LXS	0°C to 105°C	SO-8
AS431LXM	0°C to 105°C	SOT-23-3

X= Tolerance (A = 0.5%; Blank = 1%; C = 2%)

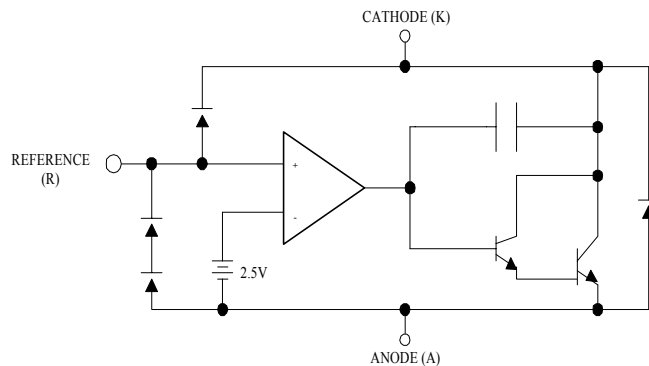

### PIN CONNECTIONS

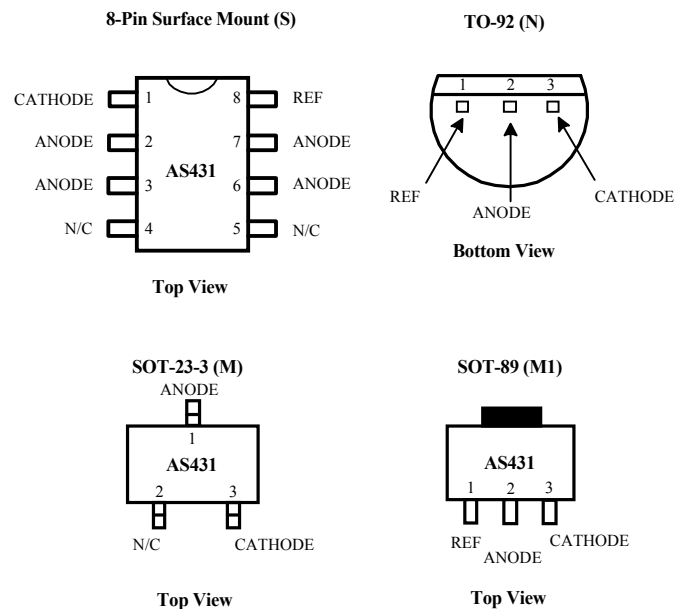

**ABSOLUTE MAXIMUM RATINGS**

Parameter	Symbol	Rating	Units
Cathode-Anode Reverse Breakdown	$V_{KA}$	30	V
Anode-Cathode Forward Current	$I_{AK}$	1	A
Operating Cathode Current	$I_{KA}$	150	mA
Reference Input Current	$I_{REF}$	10	mA
Continuous Power Dissipation at 25°C	$P_D$		
TO-92		775	mW
SOT-23		200	mW
SOIC-8		750	mW
SOT-89		1000	mW
Junction Temperature	$T_J$	150	°C
Storage Temperature	$T_{STG}$	-65 to +150	°C
Lead Temperature (Soldering 10 sec.)	$T_L$	300	°C

Stresses greater than those listed under ABSOLUTE MAXIMUM RATINGS may cause permanent damage to the device. This is a stress rating only and functional operation of the device at these or any other conditions above those indicated in the operational sections of this specification is not implied. Exposure to absolute maximum rating conditions for extended periods may affect reliability.

**RECOMMENDED CONDITIONS**

Parameter	Symbol	Rating	Unit
Cathode Voltage	$V_{KA}$	$V_{REF}$ to 20	V
Cathode Current	$I_K$	10	mA

**TYPICAL THERMAL RESISTANCE**

Package Type	$\theta_{JA}$	$\theta_{JC}$	Typical Derating
TO-92	160°C/W	80°C/W	6.3 mW/°C
SOT-23	575°C/W	150°C/W	1.7 mW/°C
SOIC-8	175°C/W	45°C/W	5.7 mW/°C
SOT-89	110°C/W	8°C/W	9.1 mW/°C

**ELECTRICAL CHARACTERISTICS** at 25°C  $I_K @ 10mA$   $V_K = V_{ref}$ , unless otherwise specified.

Parameter	Symbol	Test Conditions	AS431LA			AS431L			AS431LC			Unit
			Min	Typ	Max	Min	Typ	Max	Min	Typ	Max	
Reference Voltage	$V_{REF}$	$T_A = 25^\circ C$ TC = 1	2.490	2.503	2.515	2.470	2.495	2.520	2.445	2.495	2.545	V
Ratio of Change in $V_{REF}$ to Cathode Voltage	$\frac{\Delta V_{REF}}{\Delta V_K}$	$V_{REF}$ to 10V 10V to 20V TC = 2	-2.7 -2	-1.0 -0.4	0.3	-2.7 -2	-1.0 -0.4	0.3	-2.7 -2	-1.0 -0.4	0.3	mV/V
Reference Input Current	$I_{REF}$	TC = 2		0.7	4		0.7	4		0.7	4	$\mu A$
$I_{REF}$ Temp Deviation	$\Delta I_{REF}$	Over Temp. TC = 2		0.4	1.2		0.4	1.2		0.4	1.2	$\mu A$
Min $I_K$ for Regulation	$I_{K(MIN)}$	TC = 1		0.4	1		0.4	1		0.4	1	mA
Off State Leakage	$I_{K(OFF)}$	$V_{REF} = 0V$ , $V_{KA} = 20V$ TC = 3		0.04	1		0.04	1		0.04	1	$\mu A$
Dynamic Output Impedance	$Z_{KA}$	TC = 1		0.15	0.5		0.15	0.5		0.15	0.5	$\Omega$

TC = Test Circuit

## \*CALCULATING AVERAGE TEMPERATURE COEFFICIENT (TC)

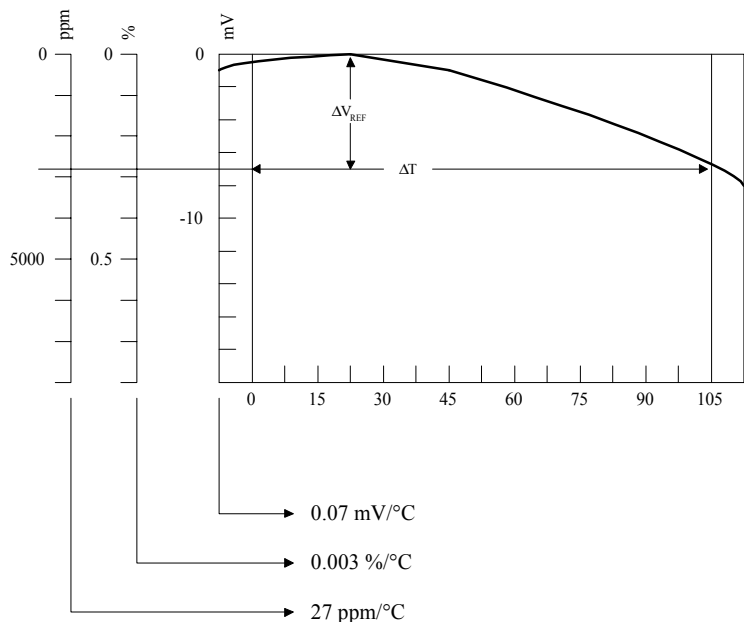

$$\bullet \text{ TC in mV/}^\circ\text{C} = \frac{\Delta V_{\text{REF}} (\text{mV})}{\Delta T_A}$$

$$\bullet \text{ TC in mV/}^\circ\text{C} = \frac{\left( \frac{\Delta V_{\text{REF}}}{\Delta V_{\text{REF}} \text{ at } 25^\circ\text{C}} \right) \times 100}{\Delta T_A}$$

$$\bullet \text{ TC in ppm/}^\circ\text{C} = \frac{\left( \frac{\Delta V_{\text{REF}}}{\Delta V_{\text{REF}} \text{ at } 25^\circ\text{C}} \right) \times 10^6}{\Delta T_A}$$

## TEST CIRCUITS

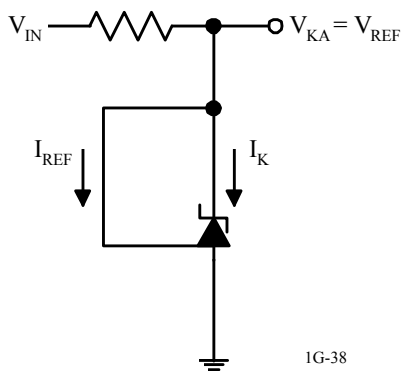

TEST CIRCUIT 1

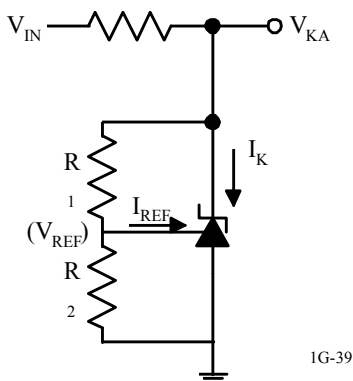

TEST CIRCUIT 2

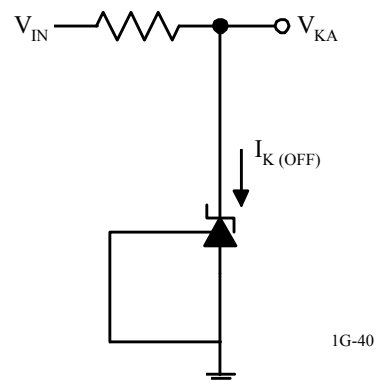

TEST CIRCUIT 3

TYPICAL PERFORMANCE CURVES

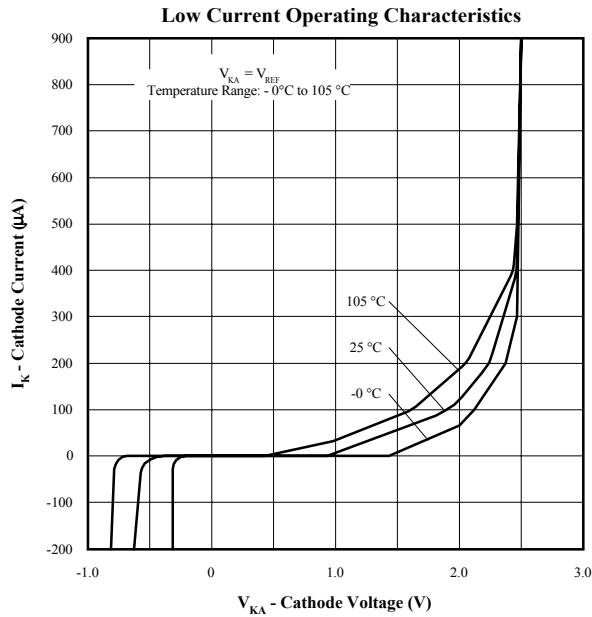

Figure 2

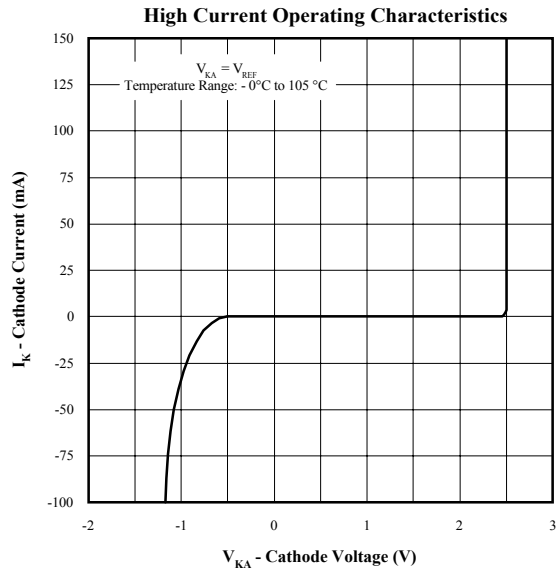

Figure 3

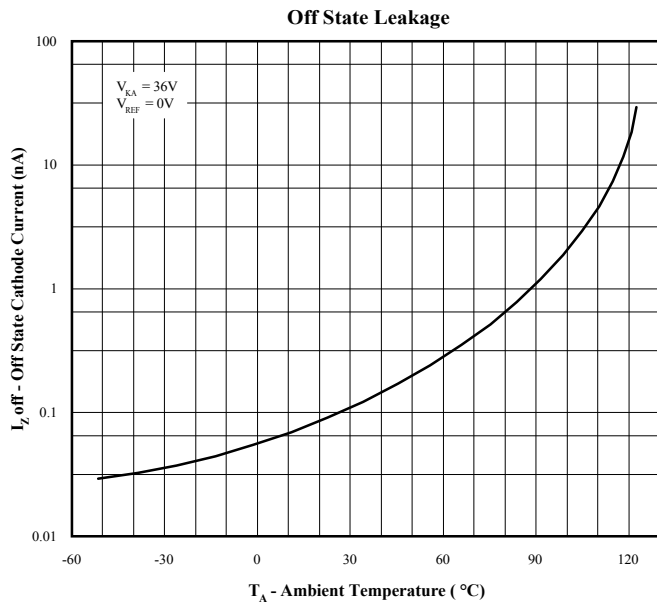

Figure 4

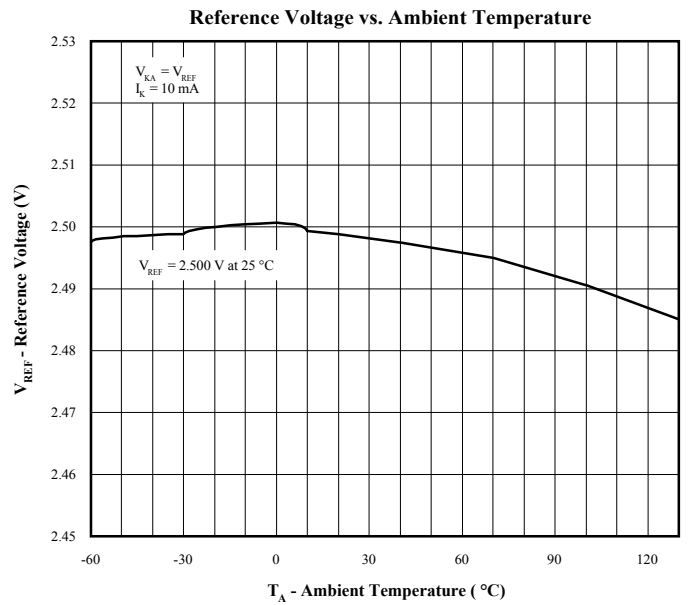

Figure 5

TYPICAL PERFORMANCE CURVES

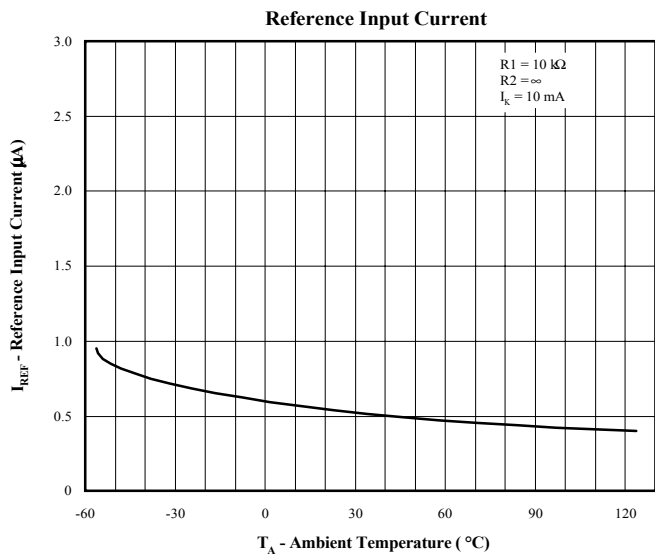

Figure 6

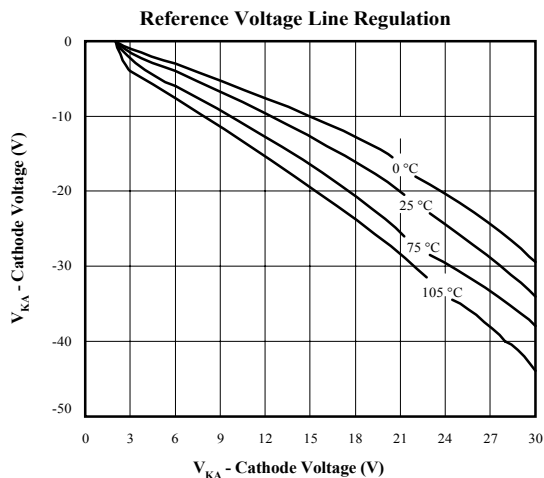

Figure 7

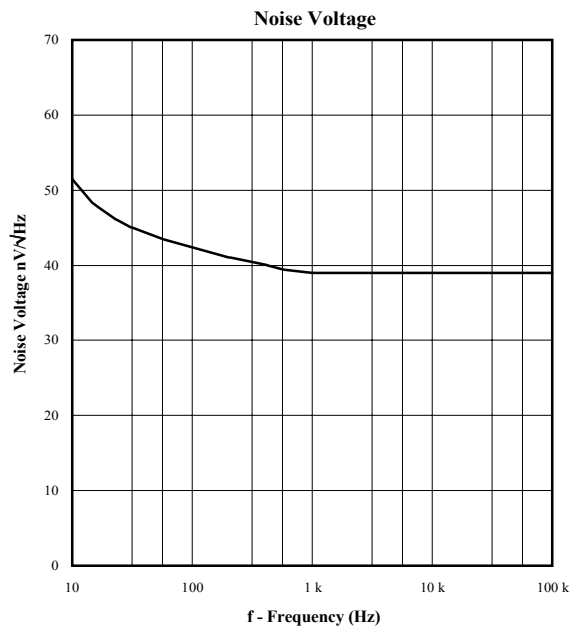

Figure 8

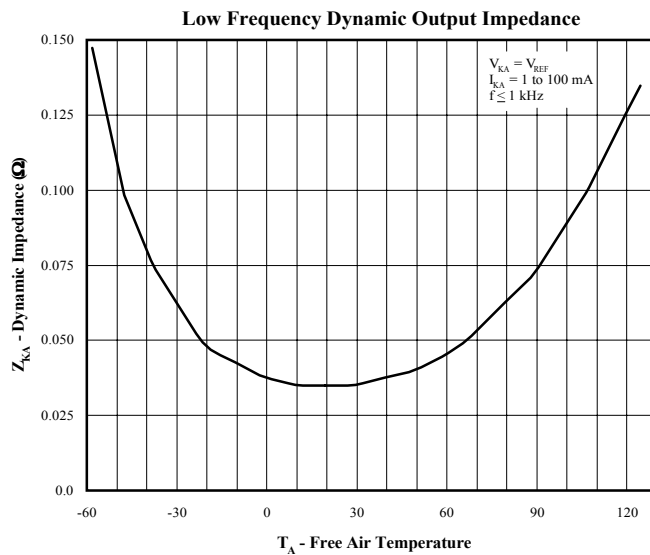
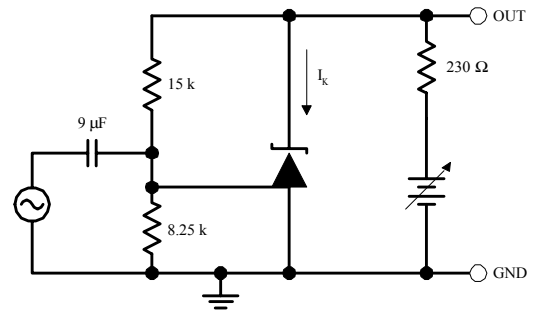
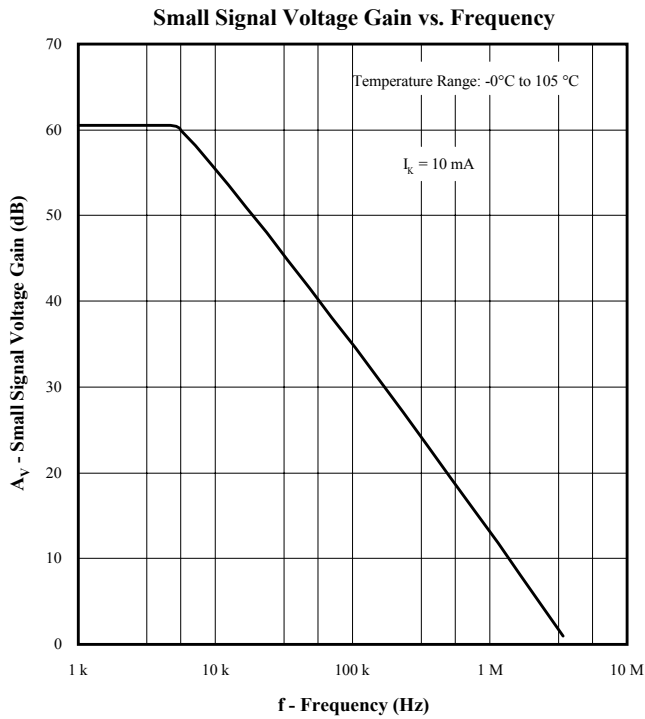
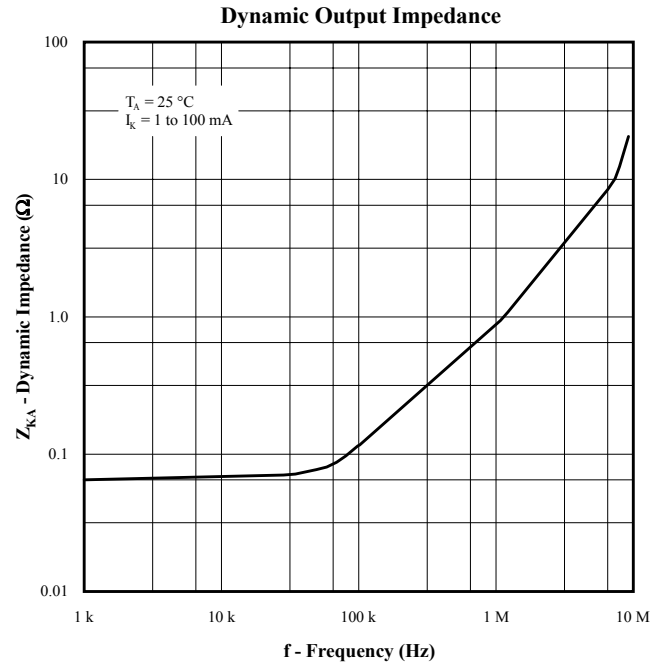

Figure 9

## TYPICAL PERFORMANCE CURVES



## TYPICAL PERFORMANCE CURVES

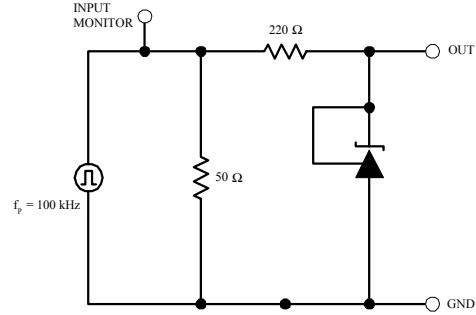
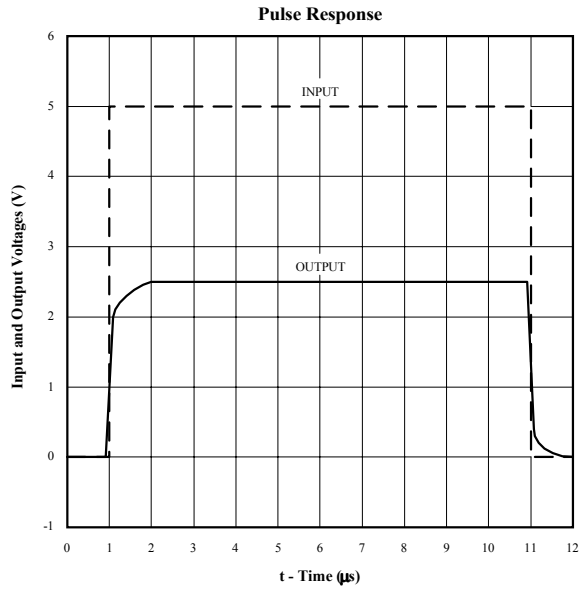

Figure 12

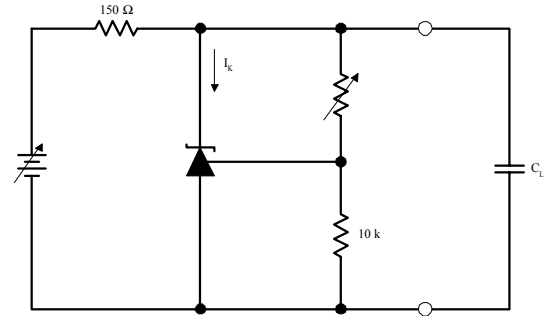
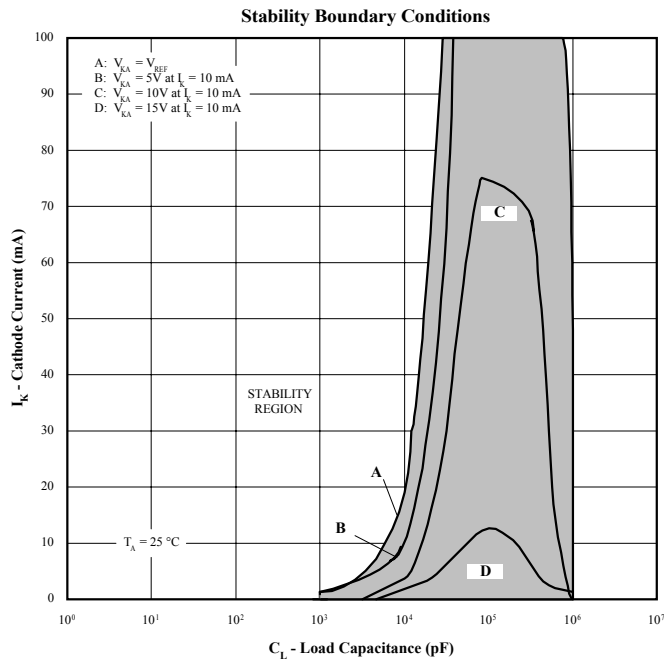

Figure 13