

AN7800R/AN78M00R Series

Positive Output Voltage Regulators with Reset pin (1A/500mA Type)

■ Overview

The AN7800R and the AN78M00R series are the fixed positive output voltage regulators with reset pin. Stabilized fixed output voltage is obtained from unstable DC input voltage without using any external components. Three types of output voltage, 5V, 9V and 12V, are available for the AN7800R series, and four types, 5V, 8V, 9V and 12V, are available for the AN78M00R series. They can be used in power circuits with current capacitance 1A/500mA. ON/OFF of output voltage can be controlled by the reset pin.

■ Features

- No external components
- Maximum output current :1A (AN7800R)
500mA (AN78M00R)
- Output voltage :5V, 9V, 12V (AN7800R)
:8V (AN78M08R)
- Short-circuit current limiting built-in
- Thermal overload protection built-in
- Output transistor safe area compensation
- ON/OFF of output voltage can be controlled by reset pin.

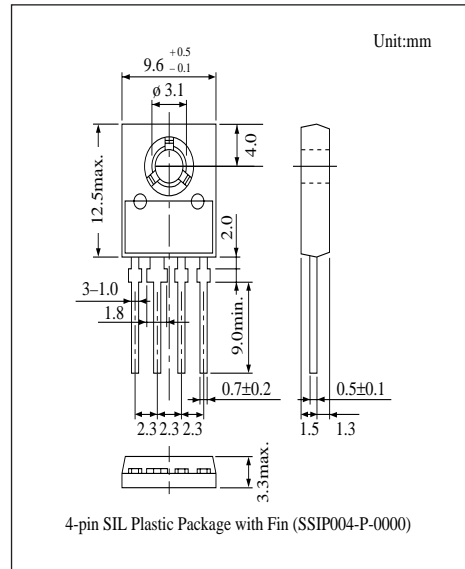

■ Block Diagram

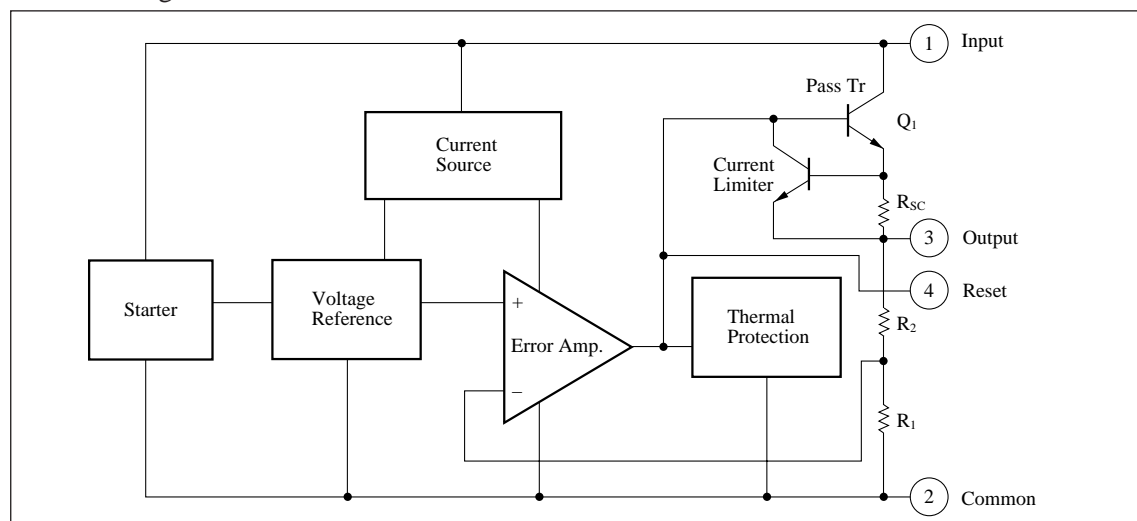

■ Absolute Maximum Ratings (Ta=25°C)

Parameter	Symbol	Rating	Unit
Input voltage	V_I	35	V
Power dissipation	P_D	10 *1	W
Operating ambient temperature	T_{opr}	-20 to + 80	°C
Storage temperature	T_{stg}	-55 to + 150	°C

*1 Follow the derating curve. When T_j exceeds 150°C, the internal circuit cuts off the output.

■ Electrical Characteristics (Ta=25°C)

AN7800R Series

- AN7805R (1A, 5V Type)

Parameter	Symbol	Condition	min	typ	max	Unit
Output voltage	V_O	$T_j=25^\circ\text{C}$	4.8	5	5.2	V
Output voltage tolerance	V_O	$V_I=8$ to 20V, $I_O=5\text{mA}$ to 1A, $T_j=0$ to 125°C, $P_D \leq 15\text{W}$	4.75	—	5.25	V
Line regulation	REG_{IN}	$V_I=7.5$ to 25V, $T_j=25^\circ\text{C}$	—	3	100	mV
		$V_I=8$ to 12V, $T_j=25^\circ\text{C}$	—	1	50	mV
Load regulation	REG_L	$I_O=5\text{mA}$ to 1.5A, $T_j=25^\circ\text{C}$	—	15	100	mV
		$I_O=250$ to 750mA, $T_j=25^\circ\text{C}$	—	5	50	mV
Bias current	I_{bias}	$T_j=25^\circ\text{C}$	—	3.9	8	mA
Input bias current fluctuation	$\Delta I_{bias (IN)}$	$V_I=7.5$ to 25V, $T_j=25^\circ\text{C}$	—	—	1.3	mA
Load bias current fluctuation	$\Delta I_{bias (L)}$	$I_O=5\text{mA}$ to 1A, $T_j=25^\circ\text{C}$	—	—	0.5	mA
Output noise voltage	V_{no}	$f=10\text{Hz}$ to 100kHz	—	40	—	μV
Ripple rejection ratio	RR	$V_I=8$ to 18V, $I_O=100\text{mA}$, $f=120\text{Hz}$	62	—	—	dB
Minimum input/output voltage difference	$V_{DIF (min.)}$	$I_O=1\text{A}$, $T_j=25^\circ\text{C}$	—	2	—	V
Output impedance	Z_O	$f=1\text{kHz}$	—	17	—	mΩ
Output short circuit current	$I_{O (Short)}$	$V_I=35\text{V}$, $T_j=25^\circ\text{C}$	—	700	—	mA
Peak output current	$I_{O (Peak)}$	$T_j=25^\circ\text{C}$	—	2	—	A
Output voltage temperature coefficient	$\Delta V_O/T_a$	$I_O=5\text{mA}$, $T_j=0$ to 125°C	—	-0.3	—	mV/°C
Output voltage at reset	$V_{O (Reset)}$	$T_j=25^\circ\text{C}$, $I_{I (Reset)}=1\text{mA}$	—	—	1	V
Reset input current	$I_{I (Reset)}$	$T_j=25^\circ\text{C}$	—	—	1	mA

Note 1) The specified condition $T_j=25^\circ\text{C}$ means that the test should be carried out with the test time so short (within 10ms) that the drift in characteristic value due to the rise in chip junction temperature can be ignored.

Note 2) When not specified, $V_I=10\text{V}$, $I_O=100\text{mA}$, $C_I=0.33\mu\text{F}$, $C_O=0.1\mu\text{F}$, $T_j=0$ to 125°C

■ Electrical Characteristics (Ta=25°C)

• AN7809R (1A, 9V Type)

Parameter	Symbol	Condition	min	typ	max	Unit
Output voltage	V_O	$T_j=25^\circ\text{C}$	8.65	9	9.35	V
Output voltage tolerance	V_O	$V_I=12$ to 24V , $I_O=5\text{mA}$ to 1A , $T_j=0$ to 125°C , $P_D \leq 15\text{W}$	8.55	—	9.45	V
Line regulation	REG _{IN}	$V_I=11.5$ to 26V , $T_j=25^\circ\text{C}$	—	7	180	mV
		$V_I=12$ to 18V , $T_j=25^\circ\text{C}$	—	2	90	mV
Load regulation	REG _L	$I_O=5\text{mA}$ to 1.5A , $T_j=25^\circ\text{C}$	—	12	180	mV
		$I_O=250$ to 750mA , $T_j=25^\circ\text{C}$	—	4	90	mV
Bias current	I_{bias}	$T_j=25^\circ\text{C}$	—	3.9	8	mA
Input bias current fluctuation	$\Delta I_{\text{bias (IN)}}$	$V_I=11.5$ to 26V , $T_j=25^\circ\text{C}$	—	—	1	mA
Load bias current fluctuation	$\Delta I_{\text{bias (L)}}$	$I_O=5\text{mA}$ to 1A , $T_j=25^\circ\text{C}$	—	—	0.5	mA
Output noise voltage	V_{no}	$f=10\text{Hz}$ to 100kHz	—	57	—	μV
Ripple rejection ratio	RR	$V_I=12$ to 22V , $I_O=100\text{mA}$, $f=120\text{Hz}$	56	—	—	dB
Minimum input/output voltage difference	$V_{\text{DIF (min.)}}$	$I_O=1\text{A}$, $T_j=25^\circ\text{C}$	—	2	—	V
Output impedance	Z_O	$f=1\text{kHz}$	—	16	—	$\text{m}\Omega$
Output short circuit current	$I_{O(\text{Short})}$	$V_I=26\text{V}$, $T_j=25^\circ\text{C}$	—	700	—	mA
Peak output current	$I_{O(\text{Peak})}$	$T_j=25^\circ\text{C}$	—	2	—	A
Output voltage temperature coefficient	$\Delta V_O/T_a$	$I_O=5\text{mA}$, $T_j=0$ to 125°C	—	-0.5	—	$\text{mV}/^\circ\text{C}$
Output voltage at reset	$V_{O(\text{Reset})}$	$T_j=25^\circ\text{C}$, $I_{I(\text{Reset})}=1\text{mA}$	—	—	1	V
Reset input current	$I_{I(\text{Reset})}$	$T_j=25^\circ\text{C}$	—	—	1	mA

Note 1) The specified condition $T_j=25^\circ\text{C}$ means that the test should be carried out with the test time so short (within 10ms) that the drift in characteristic value due to the rise in chip junction temperature can be ignored.

Note 2) When not specified, $V_I=15\text{V}$, $I_O=100\text{mA}$, $C_I=0.33\mu\text{F}$, $C_O=0.1\mu\text{F}$, $T_j=0$ to 125°C

• AN7812R (1A, 12V Type)

Parameter	Symbol	Condition	min	typ	max	Unit
Output voltage	V_O	$T_j=25^\circ\text{C}$	11.5	12	12.5	V
Output voltage tolerance	V_O	$V_I=15$ to 27V , $I_O=5\text{mA}$ to 1A , $T_j=0$ to 125°C , $P_D \leq 15\text{W}$	11.4	—	12.6	V
Line regulation	REG _{IN}	$V_I=14.5$ to 30V , $T_j=25^\circ\text{C}$	—	10	240	mV
		$V_I=16$ to 22V , $T_j=25^\circ\text{C}$	—	3	120	mV
Load regulation	REG _L	$I_O=5\text{mA}$ to 1.5A , $T_j=25^\circ\text{C}$	—	12	240	mV
		$I_O=250$ to 750mA , $T_j=25^\circ\text{C}$	—	4	120	mV
Bias current	I_{bias}	$T_j=25^\circ\text{C}$	—	4	8	mA
Input bias current fluctuation	$\Delta I_{\text{bias (IN)}}$	$V_I=14.5$ to 30V , $T_j=25^\circ\text{C}$	—	—	1	mA
Load bias current fluctuation	$\Delta I_{\text{bias (L)}}$	$I_O=5\text{mA}$ to 1A , $T_j=25^\circ\text{C}$	—	—	0.5	mA
Output noise voltage	V_{no}	$f=10\text{Hz}$ to 100kHz	—	75	—	μV
Ripple rejection ratio	RR	$V_I=15$ to 25V , $I_O=100\text{mA}$, $f=120\text{Hz}$	55	—	—	dB
Minimum input/output voltage difference	$V_{\text{DIF (min.)}}$	$I_O=1\text{A}$, $T_j=25^\circ\text{C}$	—	2	—	V
Output impedance	Z_O	$f=1\text{kHz}$	—	18	—	$\text{m}\Omega$
Output short circuit current	$I_{O(\text{Short})}$	$V_I=35\text{V}$, $T_j=25^\circ\text{C}$	—	700	—	mA
Peak output current	$I_{O(\text{Peak})}$	$T_j=25^\circ\text{C}$	—	2	—	A
Output voltage temperature coefficient	$\Delta V_O/T_a$	$I_O=5\text{mA}$, $T_j=0$ to 125°C	—	-0.8	—	$\text{mV}/^\circ\text{C}$
Output voltage at reset	$V_{O(\text{Reset})}$	$T_j=25^\circ\text{C}$, $I_{I(\text{Reset})}=1\text{mA}$	—	—	1	V
Reset input current	$I_{I(\text{Reset})}$	$T_j=25^\circ\text{C}$	—	—	1	mA

Note 1) The specified condition $T_j=25^\circ\text{C}$ means that the test should be carried out with the test time so short (within 10ms) that the drift in characteristic value due to the rise in chip junction temperature can be ignored.

Note 2) When not specified, $V_I=19\text{V}$, $I_O=100\text{mA}$, $C_I=0.33\mu\text{F}$, $C_O=0.1\mu\text{F}$, $T_j=0$ to 125°C

■ Electrical Characteristics (Ta=25°C)

AN78M00R Series

• AN78M05R (500mA, 5V Type)

Parameter	Symbol	Condition	min	typ	max	Unit
Output voltage	V_O	$T_j=25^\circ\text{C}$	4.8	5	5.2	V
Output voltage tolerance	V_O	$V_I=7.5$ to 20V, $I_O=5$ to 350mA, $T_j=0$ to 125°C, $P_D \leq 15\text{W}$	4.75	—	5.25	V
Line regulation	REG _{IN}	$V_I=7.5$ to 25V, $T_j=25^\circ\text{C}$	—	3	100	mV
		$V_I=8$ to 25V, $T_j=25^\circ\text{C}$	—	1	50	mV
Load regulation	REG _L	$I_O=5$ to 500mA, $T_j=25^\circ\text{C}$	—	20	100	mV
		$I_O=5$ to 200mA, $T_j=25^\circ\text{C}$	—	10	50	mV
Bias current	I_{bias}	$T_j=25^\circ\text{C}$	—	4.6	6	mA
Input bias current fluctuation	$\Delta I_{\text{bias (IN)}}$	$V_I=8$ to 25V, $T_j=25^\circ\text{C}$	—	—	0.8	mA
Load bias current fluctuation	$\Delta I_{\text{bias (L)}}$	$I_O=5$ to 350mA, $T_j=25^\circ\text{C}$	—	—	0.5	mA
Output noise voltage	V_{no}	$f=10\text{Hz}$ to 100kHz	—	40	—	μV
Ripple rejection ratio	RR	$V_I=8$ to 18V, $I_O=100\text{mA}$, $f=120\text{Hz}$	62	—	—	dB
Minimum input/output voltage difference	$V_{\text{DIF (min.)}}$	$I_O=500\text{mA}$, $T_j=25^\circ\text{C}$	—	2	—	V
Output short circuit current	$I_{O(\text{Short})}$	$V_I=35\text{V}$, $T_j=25^\circ\text{C}$	—	300	—	mA
Peak output current	$I_{O(\text{Peak})}$	$T_j=25^\circ\text{C}$	—	700	—	mA
Output voltage temperature coefficient	$\Delta V_O/T_a$	$I_O=5\text{mA}$, $T_j=0$ to 125°C	—	-0.5	—	mV/°C
Output voltage at reset	$V_{O(\text{Reset})}$	$T_j=25^\circ\text{C}$, $I_{I(\text{Reset})}=1\text{mA}$	—	—	1	V
Reset input current	$I_{I(\text{Reset})}$	$T_j=25^\circ\text{C}$	—	—	1	mA

Note 1) The specified condition $T_j=25^\circ\text{C}$ means that the test should be carried out with the test time so short (within 10ms) that the drift in characteristic value due to the rise in chip junction temperature can be ignored.

Note 2) When not specified, $V_I=10\text{V}$, $I_O=350\text{mA}$, $C_I=0.33\mu\text{F}$, $C_O=0.1\mu\text{F}$, $T_j=0$ to 125°C

• AN78M08R (500mA, 8V Type)

Parameter	Symbol	Condition	min	typ	max	Unit
Output voltage	V_O	$T_j=25^\circ\text{C}$	7.7	8	8.3	V
Output voltage tolerance	V_O	$V_I=10.5$ to 23V, $I_O=5$ to 350mA, $T_j=0$ to 125°C, $P_D \leq 15\text{W}$	7.6	—	8.4	V
Line regulation	REG _{IN}	$V_I=10.5$ to 25V, $T_j=25^\circ\text{C}$	—	6	100	mV
		$V_I=11$ to 25V, $T_j=25^\circ\text{C}$	—	2	50	mV
Load regulation	REG _L	$I_O=5$ to 500mA, $T_j=25^\circ\text{C}$	—	25	160	mV
		$I_O=5$ to 200mA, $T_j=25^\circ\text{C}$	—	10	80	mV
Bias current	I_{bias}	$T_j=25^\circ\text{C}$	—	4.1	6	mA
Input bias current fluctuation	$\Delta I_{\text{bias (IN)}}$	$V_I=10.5$ to 25V, $T_j=25^\circ\text{C}$	—	—	0.8	mA
Load bias current fluctuation	$\Delta I_{\text{bias (L)}}$	$I_O=5$ to 350mA, $T_j=25^\circ\text{C}$	—	—	0.5	mA
Output noise voltage	V_{no}	$f=10\text{Hz}$ to 100kHz	—	52	—	μV
Ripple rejection ratio	RR	$V_I=11.5$ to 21.5V, $I_O=100\text{mA}$, $f=120\text{Hz}$	56	—	—	dB
Minimum input/output voltage difference	$V_{\text{DIF (min.)}}$	$I_O=500\text{mA}$, $T_j=25^\circ\text{C}$	—	2	—	V
Output short circuit current	$I_{O(\text{Short})}$	$V_I=35\text{V}$, $T_j=25^\circ\text{C}$	—	300	—	mA
Peak output current	$I_{O(\text{Peak})}$	$T_j=25^\circ\text{C}$	—	0.7	—	A
Output voltage temperature coefficient	$\Delta V_O/T_a$	$I_O=5\text{mA}$, $T_j=0$ to 125°C	—	-0.5	—	mV/°C
Output voltage at reset	$V_{O(\text{Reset})}$	$T_j=25^\circ\text{C}$, $I_{I(\text{Reset})}=1\text{mA}$	—	—	1	V
Reset input current	$I_{I(\text{Reset})}$	$T_j=25^\circ\text{C}$	—	—	1	mA

Note 1) The specified condition $T_j=25^\circ\text{C}$ means that the test should be carried out with the test time so short (within 10ms) that the drift in characteristic value due to the rise in chip junction temperature can be ignored.

Note 2) When not specified, $V_I=14\text{V}$, $I_O=350\text{mA}$, $C_I=0.33\mu\text{F}$, $C_O=0.1\mu\text{F}$, $T_j=0$ to 125°C

■ Electrical Characteristics (Ta=25°C)

• AN78M09R (500mA, 9V Type)

Parameter	Symbol	Condition	min	typ	max	Unit
Output voltage	V_O	$T_j=25^\circ\text{C}$	8.65	9	9.35	V
Output voltage tolerance	V_O	$V_i=11.5$ to 24V, $I_O=5$ to 350mA, $T_j=0$ to 125°C, $P_D \leq 15\text{W}$	8.55	—	9.45	V
Line regulation	REG _{IN}	$V_i=11.5$ to 25V, $T_j=25^\circ\text{C}$	—	7	100	mV
		$V_i=12$ to 25V, $T_j=25^\circ\text{C}$	—	2	50	mV
Load regulation	REG _L	$I_O=5$ to 500mA, $T_j=25^\circ\text{C}$	—	25	180	mV
		$I_O=5$ to 200mA, $T_j=25^\circ\text{C}$	—	10	90	mV
Bias current	I_{bias}	$T_j=25^\circ\text{C}$	—	4.1	6.0	mA
Input bias current fluctuation	$\Delta I_{\text{bias (IN)}}$	$V_i=12$ to 25V, $T_j=25^\circ\text{C}$	—	—	0.8	mA
Load bias current fluctuation	$\Delta I_{\text{bias (L)}}$	$I_O=5$ to 350mA, $T_j=25^\circ\text{C}$	—	—	0.5	mA
Output noise voltage	V_{no}	f=10Hz to 100kHz	—	60	—	μV
Ripple rejection ratio	RR	$V_i=12$ to 22V, $I_O=100\text{mA}$, f=120Hz	56	—	—	dB
Minimum input/output voltage difference	$V_{\text{DIF (min.)}}$	$I_O=500\text{mA}$, $T_j=25^\circ\text{C}$	—	2	—	V
Output short circuit current	$I_{O(\text{Short})}$	$V_i=35\text{V}$, $T_j=25^\circ\text{C}$	—	300	—	mA
Peak output current	$I_{O(\text{Peak})}$	$T_j=25^\circ\text{C}$	—	0.7	—	A
Output voltage temperature coefficient	$\Delta V_O/T_a$	$I_O=5\text{mA}$, $T_j=0$ to 125°C	—	-0.5	—	mV/°C
Output voltage at reset	$V_O(\text{Reset})$	$T_j=25^\circ\text{C}$, $I_{I(\text{Reset})}=1\text{mA}$	—	—	1	V
Reset input current	$I_{I(\text{Reset})}$	$T_j=25^\circ\text{C}$	—	—	1	mA

Note 1) The specified condition $T_j=25^\circ\text{C}$ means that the test should be carried out with the test time so short (within 10ms) that the drift in characteristic value due to the rise in chip junction temperature can be ignored.

Note 2) When not specified, $V_i=15\text{V}$, $I_O=350\text{mA}$, $C_i=0.33\mu\text{F}$, $C_o=0.1\mu\text{F}$, $T_j=0$ to 125°C

• AN78M12R (500mA, 12V Type)

Parameter	Symbol	Condition	min	typ	max	Unit
Output voltage	V_O	$T_j=25^\circ\text{C}$	11.5	12	12.5	V
Output voltage tolerance	V_O	$V_i=14.5$ to 27V, $I_O=5$ to 350mA, $T_j=0$ to 125°C, $P_D \leq 15\text{W}$	11.4	—	12.6	V
Line regulation	REG _{IN}	$V_i=14.5$ to 30V, $T_j=25^\circ\text{C}$	—	8	100	mV
		$V_i=16$ to 30V, $T_j=25^\circ\text{C}$	—	2	50	mV
Load regulation	REG _L	$I_O=5$ to 500mA, $T_j=25^\circ\text{C}$	—	25	240	mV
		$I_O=5$ to 200mA, $T_j=25^\circ\text{C}$	—	10	120	mV
Bias current	I_{bias}	$T_j=25^\circ\text{C}$	—	4.3	6	mA
Input bias current fluctuation	$\Delta I_{\text{bias (IN)}}$	$V_i=14.5$ to 30V, $T_j=25^\circ\text{C}$	—	—	0.8	mA
Load bias current fluctuation	$\Delta I_{\text{bias (L)}}$	$I_O=5$ to 350mA, $T_j=25^\circ\text{C}$	—	—	0.5	mA
Output noise voltage	V_{no}	f=10Hz to 100kHz	—	75	—	μV
Ripple rejection ratio	RR	$V_i=15$ to 25V, $I_O=100\text{mA}$, f=120Hz	55	—	—	dB
Minimum input/output voltage difference	$V_{\text{DIF (min.)}}$	$I_O=500\text{mA}$, $T_j=25^\circ\text{C}$	—	2	—	V
Output short circuit current	$I_{O(\text{Short})}$	$V_i=35\text{V}$, $T_j=25^\circ\text{C}$	—	300	—	mA
Peak output current	$I_{O(\text{Peak})}$	$T_j=25^\circ\text{C}$, $V_i=35\text{V}$	—	700	—	mA
Output voltage temperature coefficient	$\Delta V_O/T_a$	$I_O=5\text{mA}$, $T_j=0$ to 125°C	—	-0.5	—	mV/°C
Output voltage at reset	$V_O(\text{Reset})$	$T_j=25^\circ\text{C}$, $I_{I(\text{Reset})}=1\text{mA}$	—	—	1	V
Reset input current	$I_{I(\text{Reset})}$	$T_j=25^\circ\text{C}$	—	—	1	mA

Note 1) The specified condition $T_j=25^\circ\text{C}$ means that the test should be carried out with the test time so short (within 10ms) that the drift in characteristic value due to the rise in chip junction temperature can be ignored.

Note 2) When not specified, $V_i=19\text{V}$, $I_O=350\text{mA}$, $C_i=0.33\mu\text{F}$, $C_o=0.1\mu\text{F}$, $T_j=0$ to 125°C

■ Characteristic Curve

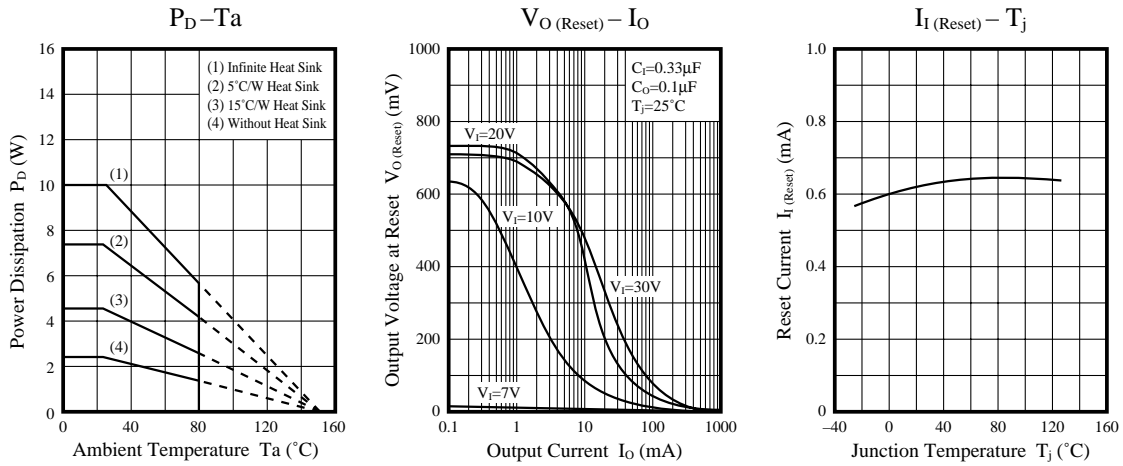

■ Basic Regulator Circuit

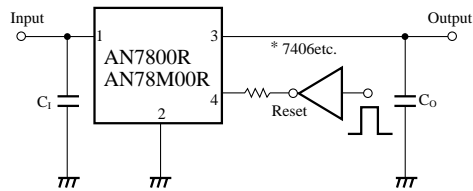

* For TTL, an open collector type inverter, buffer, gate etc. can be used.
 Beware of the breakdown of TTL, as the reset pin bears voltage higher than the output voltage V_O by 1—2V.
 C_i is set when the input line is long.
 C_o improves the temperature response.

■ Application Circuit

(1) Soft Start Circuit

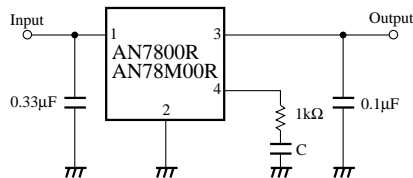

(2) Several Output Reset Circuits

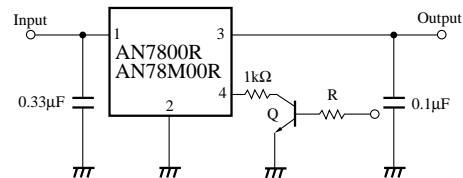

* Control of Output Voltage Rise Time

