

# AN7114

## 1 W 低周波電力増幅回路 / 1 W Audio Power Amplifier Circuit

### ■ 概要 / Description

AN7114 は、電源電圧 6 V、負荷 4 Ω で 1 W の出力が得られるオーディオ出力用半導体集積回路です。無信号時の電流が少なく、乾電池動作のカセットテープレコーダ、ラジオ、ポータブルレコーダプレーヤなどの出力段に好適です。

### ■ 特徴 / Features

- 低電圧動作で高出力 :  $P_O = 1 \text{ W typ. (6 V, 4 } \Omega)$
- 無信号時の電流が少ない
- フィン付 14 ピンプラスチック DIL パッケージ
- High power output at low voltage :  $P_O = 1 \text{ W typ. (6 V, 4 } \Omega)$
- Low quiescent current
- 14-lead dual-in-line package with fin

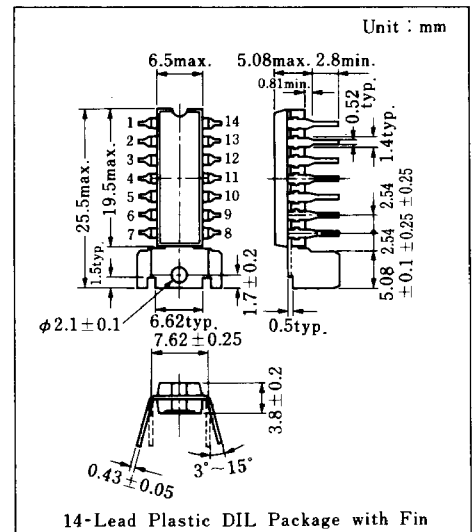

### ■ 等価回路 / Schematic Diagram

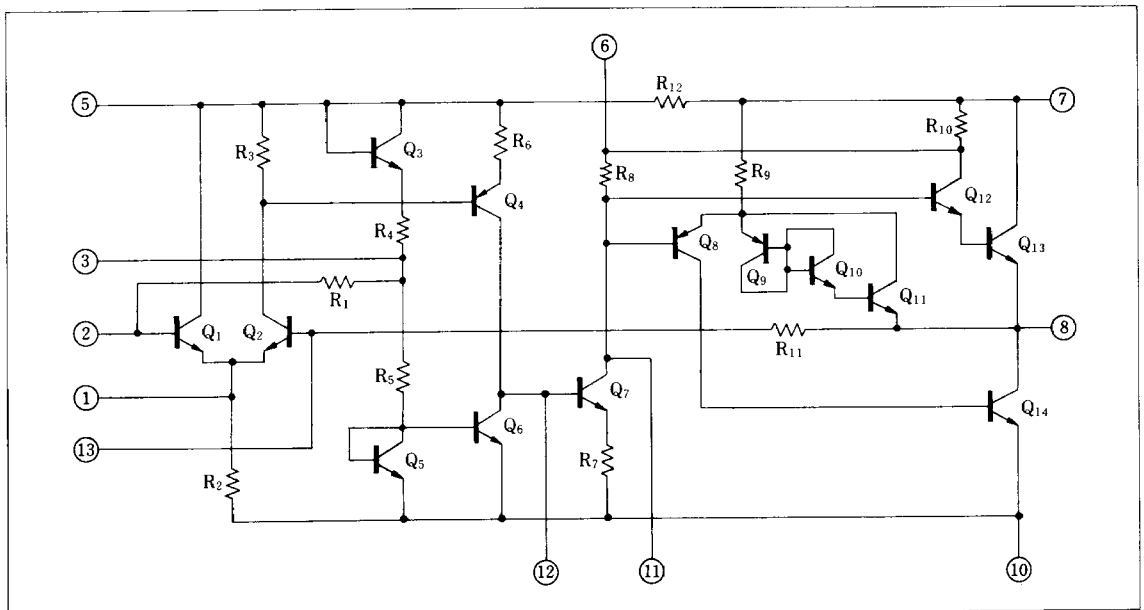

■ 絶対最大定格/Absolute Maximum Ratings (Ta = 25°C)

Item	Symbol	Rating	Unit
電源電圧	V <sub>CC</sub>	11	V
電源電流	I <sub>CC(peak)</sub>	1.5	A
許容損失 (Ta ≤ 60°C)	P <sub>D</sub>	1.2 (2.25*)	W
動作周囲温度	T <sub>opr</sub>	-20 ~ +70	°C
保存温度	T <sub>stg</sub>	-40 ~ +150	°C

\* 50×50mm 銅箔付プリント基板使用。

■ 電気的特性/Electrical Characteristics (V<sub>CC</sub> = 6V, R<sub>L</sub> = 4Ω, f = 1kHz, Ta = 25°C)

Item	Symbol	Test Circuit	Condition	min.	typ.	max.	Unit
静止回路電流	I <sub>CQ</sub>	1	V <sub>i</sub> = 0		15	25	mA
開回路電圧利得	G <sub>VO</sub>		V <sub>i</sub> = 0.2 mV		70		dB
閉回路電圧利得	G <sub>VC</sub>	1	V <sub>i</sub> = 5 mV	42	45	48	dB
出力電力	P <sub>O</sub>	1	THD = 10%	0.65	1		W
			V <sub>CC</sub> = 6V, R <sub>L</sub> = 8Ω, THD = 10%		0.6		W
			V <sub>CC</sub> = 7.5V, R <sub>L</sub> = 4Ω, THD = 10%	0.95	1.5		W
			V <sub>CC</sub> = 7.5V, R <sub>L</sub> = 8Ω, THD = 10%		0.9		W
全高調波歪率	THD	1	V <sub>i</sub> = 5 mV		0.5	1.5	%
出力雑音電圧	V <sub>no</sub>	1	R <sub>g</sub> = 10kΩ			3	mV
			R <sub>g</sub> = 0			1	mV
入力インピーダンス	Z <sub>i</sub>			12	20		kΩ

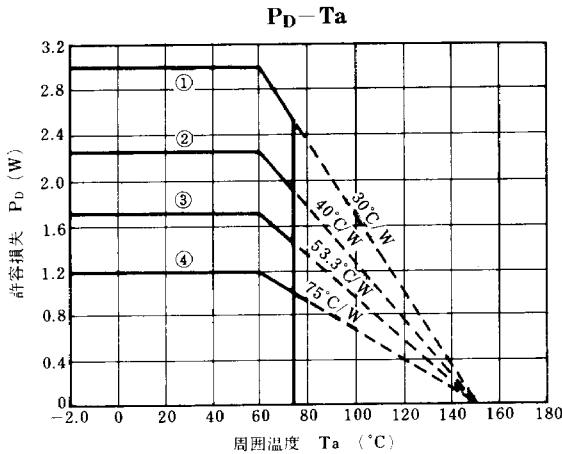

- ① With a 100×100×1.5mm Al heat sink
- ② With a 50×50×1.5mm bakelite printed circuit board (3.5 μ Cu leaf) or 50×50×1.5mm Al heat sink
- ③ With a 100×100×1.5mm bakelite printed circuit board
- ④ Without heat sink

Test Circuit 1

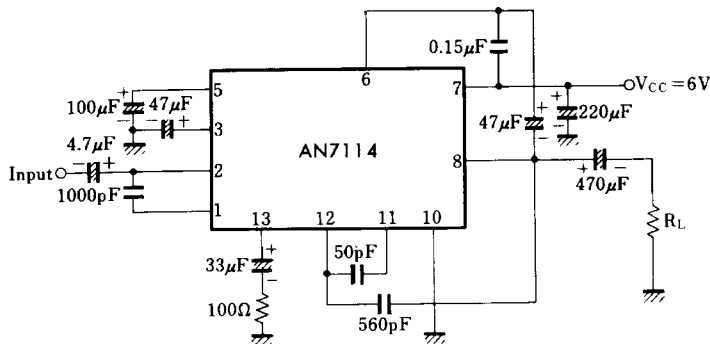

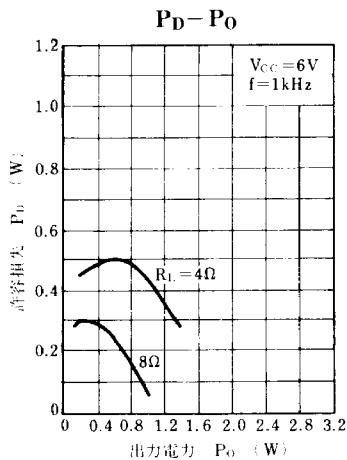
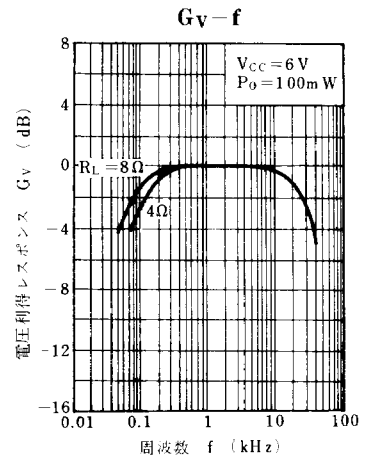
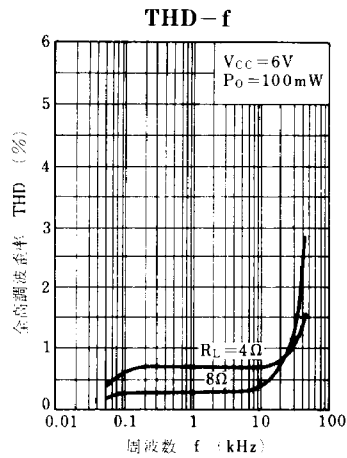
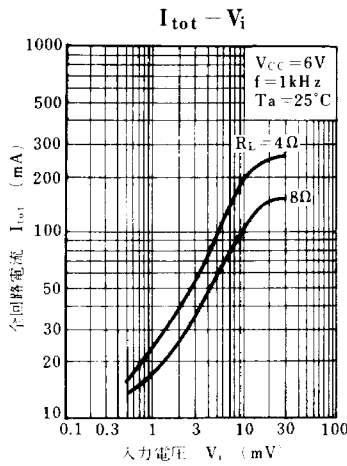
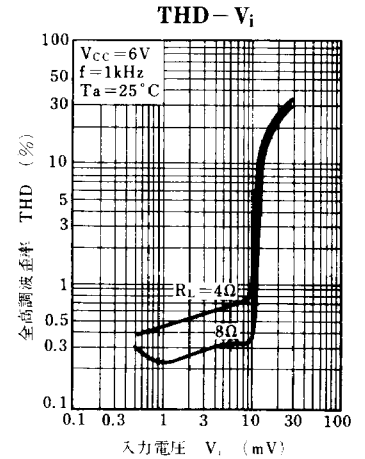
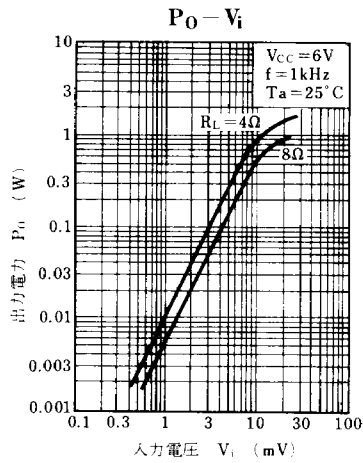
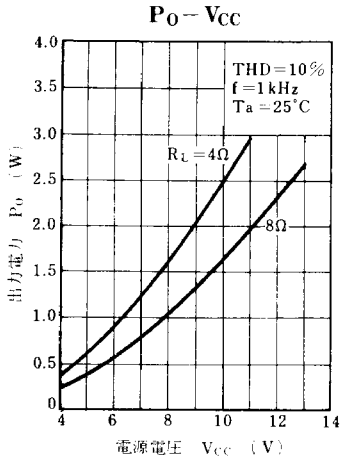

■ 応用回路例 / Application Circuit

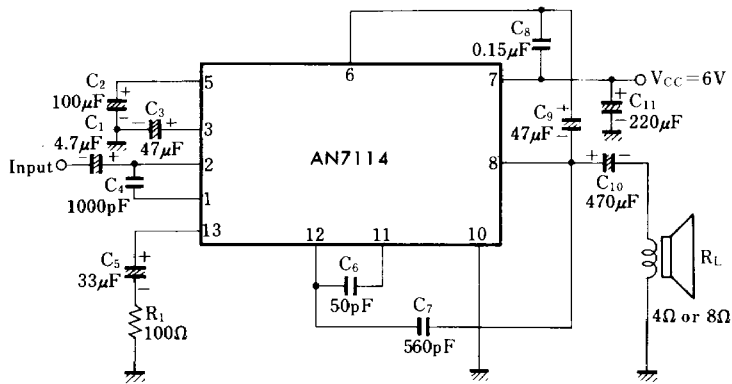

■ プリント板パターン例 / Printed Circuit Board Layout

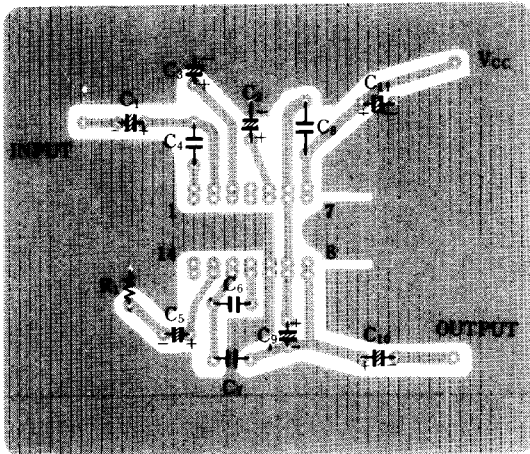

$R_1 = 100 \Omega$	$C_5 = 33 \mu\text{F}$
	$C_6 = 50 \text{ pF}$
	$C_7 = 560 \text{ pF}$
$C_1 = 4.7 \mu\text{F}$	$C_8 = 0.15 \mu\text{F}$
$C_2 = 100 \mu\text{F}$	$C_9 = 47 \mu\text{F}$
$C_3 = 47 \mu\text{F}$	$C_{10} = 470 \mu\text{F}$
$C_4 = 1000 \text{ pF}$	$C_{11} = 220 \mu\text{F}$